

APPLIED THERMODYNAMICS FOR ENGINEERS

BY

WILLIAM D. ENNIS, M.E.

MEMBER OF AMERICAN SOCIETY OF MECHANICAL ENGINEERS
PROFESSOR OF MECHANICAL ENGINEERING IN THE
POLYTECHNIC INSTITUTE OF BROOKLYN

WITH 316 ILLUSTRATIONS

Third Edition, Revised and Enlarged



NEW YORK
D. VAN NOSTRAND COMPANY
25 PARK PLACE
1913

TJ265
.E6
1913

COPYRIGHT, 1910, BY
D. VAN NOSTRAND COMPANY

—————
COPYRIGHT, 1913, BY
D. VAN NOSTRAND COMPANY

13-15868



THE SCIENTIFIC PRESS
ROBERT DRUMMOND AND COMPANY
BROOKLYN, N. Y.

\$4.50

©Cl.A350418

201

PREFACE TO THE THIRD EDITION.

THIS book was published in the fall of 1910. It was the first new American book in its field that had appeared in twenty years. It was not only new in time, it was new in plan. The present edition, which represents a third printing, thus demands careful revision.

The revision has been comprehensive and has unfortunately somewhat increased the size of the book—a defect which further time may, however, permit to be overcome. Such errors in statement or typography as have been discovered have been eliminated. Improved methods of presentation have been adopted wherever such action was possible. Answers to many of the numerical problems have now been incorporated, and additional problems set.

Expanded treatment has been given the kinetic theory of gases and the flow of gases; and results of recent studies of the properties of steam have been discussed. There will be found a brief study of gas and vapor mixtures, undertaken with special reference to the use of mixtures in heat engines. The gas engine cycle has been subjected to an analysis which takes account of the varying specific heats of the gases. The section on pressure turbines has been rewritten, as has also the whole of Chapter XV, on results of engine tests—the latter after an entirely new plan. A new method of design of compound engines has been introduced. Some developments from the engineering practice of the past three years are discussed—such as Orrok's condenser constants; Clayton's studies of cylinder action (with application to the Hirn analysis and the entropy diagram), the Humphrey internal combustion pump, the Stumpf uniflow engine and various gas-engine cycles. The section on absorption systems of refrigeration has been extended to include the method of computing a heat balance. Brief additional sections on applications of the laws of gases to ordnance and to balloon construction are submitted. A table of symbols have been prefixed to the text, and a "reminder" page on the forms of logarithmic transformation

may be found useful. The Tyler method of solving exponential equations by hyperbolic functions will certainly be found new.

In spite of these changes, the inductive method is retained to the largest extent that has seemed practicable. The function of the book is to lead the student from what is the simple and obvious fact of daily experience to the comprehensive generalization. This seems more useful than the reverse procedure.

POLYTECHNIC INSTITUTE OF BROOKLYN,
NEW YORK, 1913.

PREFACE TO THE FIRST EDITION

“APPLIED THERMODYNAMICS” is a pretty broad title; but it is intended to describe a method of treatment rather than unusual scope. The writer’s aim has been to present those fundamental principles which concern the designer no less than the technical student in such a way as to convince of their importance.

The vital problem of the day in mechanical engineering is that of the prime mover. Is the steam engine, the gas engine, or the turbine to survive? The internal combustion engine works with the wide range of temperature shown by Carnot to be desirable; but practically its superiority in efficiency is less marked than its temperature range should warrant. In most forms, its entire charge, and in all forms, the greater part of its charge, must be compressed by a separate and thermally wasteful operation. By using liquid or solid fuel, this complication may be limited so as to apply to the air supply only; but as this air supply constitutes the greater part of the combustible mixture, the difficulties remain serious, and there is no present means available for supplying oxygen in liquid or solid form so as to wholly avoid the necessity for compression.

The turbine, with superheat and high vacuum, has not yet surpassed the best efficiency records of the reciprocating engine, although commercially its superior in many applications. Like the internal combustion engine, the turbine, with its wide temperature range, has gone far toward offsetting its low efficiency ratio; where the temperature range has been narrow the economy has been low, and when running non-condensing the efficiency of the turbine has compared unfavorably with that of the engine. There is promise of development along the line of attack on the energy losses in the turbine; there seems little to be accomplished in reducing these losses in the engine. The two motors may at any moment reach a parity.

These are the questions which should be kept in mind by the reader. Thermodynamics is physics, not mathematics or logic. This book takes a middle ground between those text-books which replace all theory by empiricism and that other class of treatises which are too apt to ignore the engineering significance of their vocabulary of differential equations. We here aim to present ideal operations, to show how they are modified in practice, to amplify underlying principles, and to stop when the further application of those principles becomes a matter of machine design. Thermodynamics has its own distinct and by no means narrow scope, and the intellectual training arising from its study is not to be ignored. We here deal only with a few of its engineering aspects; but these, with all others, hark back invariably to a few fundamental principles, and these principles are the matters for insistent emphasis. Too much anxiety is sometimes shown to quickly reach rules of practice. This, perhaps, has made our subject too often the barren science. Rules of practice eternally change; for they depend not alone on underlying theory, but on conditions current. Our theory should be so sound, and our grasp of underlying principles so just, that we may successfully attack new problems as they arise and evolve those rules of practice which at any moment may be best for the conditions existing at that moment.

But if Thermodynamics is not differential equations, neither should too much trouble be taken to avoid the use of mathematics which every engineer is supposed to have mastered. The calculus is accordingly employed where it saves time and trouble, not elsewhere. The so-called general mathematical method has been used in the one application where it is still necessary; elsewhere, special methods, which give more physical significance to the things described, have been employed in preference. Formulas are useful to the busy engineer, but destructive to the student; and after weighing the matter the writer has chosen to avoid formal definitions and too binding symbols, preferring to compel the occasionally reluctant reader to grub out roots for himself—an excellent exercise which becomes play by practice.

The subject of compressed air is perhaps not Thermodynamics, but it illustrates in a simple way many of the principles of gases

and has therefore been included. Some other topics may convey an impression of novelty; the gas engine is treated before the steam engine, because if the order is reversed the reader will usually be rusty on the theory of gases after spending some weeks with vapor phenomena; a brief exposition of multiple-effect distillation is presented; a limit is suggested for the efficiency of the power gas producer; and, carrying out the general use of the entropy diagram for illustrative purposes, new entropy charts have been prepared for ammonia, ether, and carbon dioxide. A large number of problems has been incorporated. Most of these should be worked with the aid of the slide rule.

Further originality is not claimed. The subject has been written, and may now be only re-presented. All standard works have been consulted, and an effort has been made to give credit for methods as well as data. Yet it would be impossible in this way to fully acknowledge the beneficial influence of the writer's former teachers, the late Professor Wood, Professor J. E. Denton, and Dr. D. S. Jacobus. It may be sufficient to say that if there is anything good in the book they have contributed to it; and for what is not good, they are not responsible.

POLYTECHNIC INSTITUTE OF BROOKLYN,
NEW YORK, August, 1910.

CONTENTS

CHAPTER	PAGE
TABLE OF SYMBOLS	xiii
I. THE NATURE AND EFFECTS OF HEAT	1
II. THE HEAT UNIT: SPECIFIC HEAT: FIRST LAW OF THERMODYNAMICS	11
III. LAWS OF GASES: ABSOLUTE TEMPERATURE: THE PERFECT GAS .	19
IV. THERMAL CAPACITIES: SPECIFIC HEATS OF GASES: JOULE'S LAW .	32
V. GRAPHICAL REPRESENTATIONS: PRESSURE-VOLUME PATHS OF PERFECT GASES	43
VI. THE CARNOT CYCLE	76
VII. THE SECOND LAW OF THERMODYNAMICS	84
VIII. ENTROPY	92
IX. COMPRESSED AIR	106
The cold air engine: cycle, temperature fall, preheaters, design of engine: the compressor: cycle, form of compression curve, jackets, multi-stage compression, intercooling, power consumption: engine and compressor relations: losses, efficiencies, entropy diagram, compressor capacity, volumetric efficiency, design of compressor, commercial types: compressed air transmission.	
X. HOT-AIR ENGINES	145
XI. GAS POWER	162
The producer: limit of efficiency: gas engine cycles: Otto, Carnot, Atkinson, Lenoir, Brayton, Clerk, Diesel, Sargent, Frith, Humphrey: practical modifications of the Otto cycle: mixture, compression, ignition, dissociation, clearance, expansion, scavenging, diagram factor: analysis with variable specific heats considered: principles of design and efficiency: commercial gas engines: results of tests: gas engine regulation.	
XII. THEORY OF VAPORS	230
Formation at constant pressure: saturated steam: mixtures: superheated steam: paths of vapors: vapors in general: steam cycles: steam tables.	

CHAPTER	PAGE
XIII. THE STEAM ENGINE	298
Practical modifications of the Rankine cycle: complete and incomplete expansion, wiredrawing, cylinder condensation, ratio of expansion, the steam jacket, use of superheated steam, actual expansion curve, mean effective pressure, back pressure, clearance, compression, valve action: the entropy diagram: cylinder feed and cushion steam, Boulvin's method, preferred method: multiple expansion: desirability of complete expansion, condensation losses in compound cylinders, Woolf engine, receiver engine, tandem and cross compounds, combined diagrams, design of compound engines, governing, drop, binary vapor engine: engine tests: indicators, calorimeters, heat supplied, heat rejected, heat transfers: regulation: types of steam engine.	
XIV. THE STEAM TURBINE	363
Conversion of heat into velocity: the turbine cycle, effects of friction, rate of flow: efficiency in directing velocities: velocity compounding, pressure compounding: efficiency of the turbine: design of impulse and pressure turbines: commercial types and applications.	
XV. RESULTS OF TRIALS OF STEAM ENGINES AND STEAM TURBINES .	397
Economy, condensing and non-condensing, of various commercial forms with saturated and superheated steam: mechanical efficiencies.	
XVI. THE STEAM POWER PLANT	415
Fuels, combustion economy, air supply, boilers, theory of draft, fans, chimneys, stokers, heaters, superheaters, economizers, condensers, pumps, injectors.	
XVII. DISTILLATION	439
The still, evaporation in vacuo, multiple-effect evaporation.	
FUSION:	
Change of volume during change of state, pressure-temperature relation, latent heat of fusion of ice.	
LIQUEFACTION OF GASES:	
Pressure and cooling, critical temperature, cascade system, regenerative apparatus.	
XVIII. MECHANICAL REFRIGERATION	454
Air machines: reversed cycle, Bell-Coleman machine, dense air apparatus, coefficient of performance, Kelvin warming machine: vapor-compression machines: the cycle, choice of fluid, tonnage rating, ice-melting effect, design of compressor: the absorption system, heat balance: methods and fields of application: ice-making: commercial efficiencies.	

CHARACTERISTIC SYMBOLS

<p>F = Fahrenheit; C = Centigrade; R = Réaumur; = Radiation (Art. 25); = gas constant for air = 53.36 ft.lb. = 0.0686 B.t.u.; = ratio of expansion; <i>P, p</i> = pressure: usually lb. per sq. in. absolute; <i>V, v</i> = volume, cu. ft: usually of 1 lb.; = velocity (Chapter XIV); <i>T, t</i> = temperature, usually absolute; <i>T</i> = heat to produce <i>change</i> of tem- perature (Art. 12); <i>E</i> = change of internal energy; <i>I</i> = disgregation work; <i>Q, H</i> = heat absorbed or emitted; = total heat above 32° of 1 lb. of dry vapor; <i>h</i> = heat emitted; = heat of liquid above 32° F; = head of liquid; <i>c</i> = constant; = specific heat; <i>s</i> = specific heat; <i>r</i> = gas constant (Art. 52); = internal heat of vaporization; = ratio of expansion; $\frac{dH}{dT}$ = specific heat; $\int \frac{dH}{T}$ = entropy;</p>	<p>34.5 lbs. water per hour from and at 212° F. = 1 boiler H.P.; 42.42 B.t.u. per min. = 1 H.P.; 2545 B.t.u. per hour = 1 H.P.; 17.59 B.t.u. per minute = 1 watt; <i>w, W</i> = weight (lb.); <i>W</i> = external mechanical work; <i>S</i> = piston speed, feet per minute; <i>A</i> = piston area, square inch; <i>k</i> = specific heat at constant pres- sure; <i>l</i> = specific heat at constant volume; $y = \frac{k}{l}$; <i>n</i> = polytropic exponent; <i>N, n</i> = entropy; <i>e</i> = coefficient of elasticity; = external work of vaporization; <i>p_m</i> = mean effective pressure; <i>D</i> = piston displacement (Art. 190); r.p.m. = revolutions per minute; H.P. = horse-power; <i>d</i> = density; <i>g</i> = 32.2; 778 = mechanical equivalent of heat; 459.6(460) = absolute temperature at Fahrenheit zero; <i>L</i> = heat of vaporization; <i>x</i> = dryness fraction; <i>F</i> = factor of evaporation; <i>n_s</i> = entropy of dry steam; <i>n_e</i> = entropy of vaporization; <i>n_w</i> = entropy of liquid.</p>
---	---

CHAPTER I

THE NATURE AND EFFECTS OF HEAT

1. Heat as Motive Power. All artificial motive powers derive their origin from heat. Muscular effort, the forces of the waterfall, the wind, tides and waves, and the energy developed by the combustion of fuel, may all be traced back to reactions induced by heat. Our solid, liquid, and gaseous *fuels* are stored-up solar heat in the forms of hydrogen and carbon.

2. Nature of Heat. We speak of bodies as "hot" or "cold," referring to certain impressions which they produce upon our senses. Common experimental knowledge regarding heat is limited to sensations of temperature. Is heat matter, force, motion, or position? The old "caloric" theory was that "heat was that *substance* whose entrance into our bodies causes the sensation of warmth, and whose egress the sensation of cold." But heat is not a "substance" similar to those with which we are familiar, for a hot body weighs no more than one which is cold. The calorists avoided this difficulty by assuming the existence of a weightless material fluid, *caloric*. This substance, present in the interstices of bodies, it was contended, produced the effects of heat; it had the property of passing between bodies over any intervening distance. Friction, for example, decreased the *capacity for caloric*; and consequently some of the latter "flowed out," as to the hand of the observer, producing the sensation of heat. Davy, however, in 1799, proved that friction does not diminish the capacity of bodies for containing heat, by rubbing together two pieces of ice until they melted. According to the caloric theory, the resulting water should have had less *capacity for heat* than the original ice: but the fact is that water has actually about twice the capacity for heat that ice has; or, in other words, the *specific heat* of water is about 1.0, while that of ice is 0.504. The caloric theory was further assailed by Rumford, who showed that the supply of heat from a body put under appropriate conditions was so nearly inexhaustible that the source thereof could not be conceived as being even an "imponderable" substance. The notion of the calorists was that the different specific heats of bodies were due to a varying capacity for caloric; that caloric might be squeezed out of a body like water from a sponge. Rumford measured the heat generated by the boring of cannon in the arsenal at Munich. In one experiment, a gun weighing

113.13 lb. was heated 70° F., although the total weight of borings produced was only 837 grains troy. In a later experiment, Rumford succeeded in boiling water by the heat thus generated. He argued that "*anything which any insulated body or system of bodies may continue to furnish without limitation cannot possibly be a material substance.*" The evolution of heat, it was contended, might continue as indefinitely as the generation of sound following the repeated striking of a bell (1).*

Joule, about 1845, showed conclusively that mechanical energy alone sufficed for the production of heat, and that *the amount of heat generated was always proportionate to the energy expended.* A view of his apparatus is given in Fig. 1, *v* and *h* being the vertical and horizontal sections, respectively, of the container shown at *c*. Water being placed in *c*, a rotary motion of the contained brass paddle wheel was caused by the descent of two leaden weights suspended by cords. The rise in temperature of the

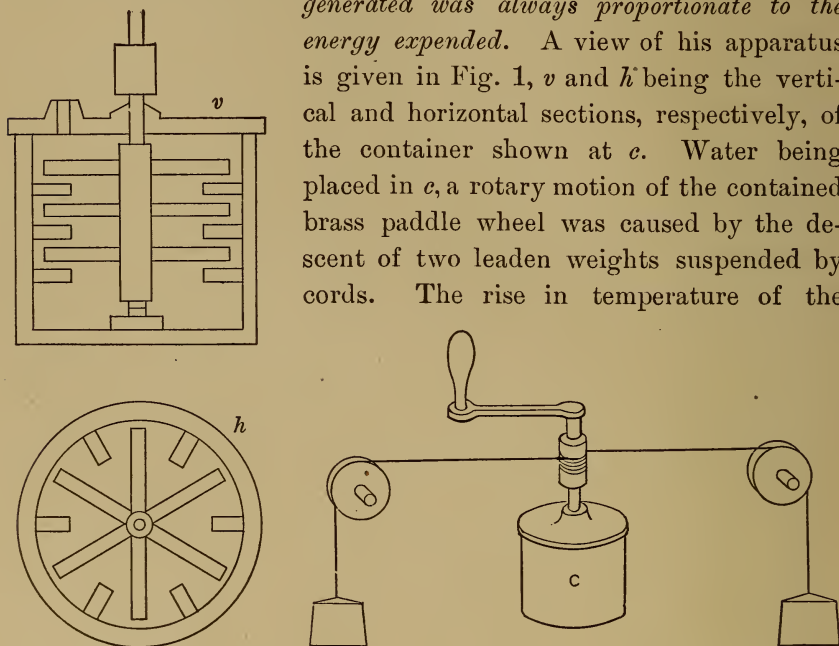

FIG. 1. Arts. 2, 30. — Joule's Apparatus.

water was noted, the expended work (by the falling weights) computed, and a proper correction made for radiation. Similar experiments were made with mercury instead of water. As a result of his experiments, Joule reached conclusions which served to finally overthrow the caloric theory.

3. Mechanical Theory of Heat. Various ancient and modern philosophers had conceded that heat was a **motion** of the minute particles of the body, some of them suggesting that such motion

* Figures in parentheses signify references grouped at the ends of the chapters.

was produced by an "igneous matter." Locke defined heat as "a very brisk agitation of the insensible parts of the object, which produces in us that sensation from which we denominate the object hot; so [that] what in our sensation is heat, in the object is nothing but motion." Young argued, "If heat be not a substance, it must be a quality; and this quality can only be a motion." This is the modern conception. Heat is energy: it can perform work, or produce certain sensations; it can be measured by its various effects. It is regarded as "energy stored in a substance by virtue of the state of its molecular motion" (2).

Conceding that heat is energy, and remembering the expression for energy, $\frac{1}{2}mv^2$, it follows that if the mass of the particle does not change, its velocity (molecular velocity) must change; or if heat is to include potential energy, then the molecular configuration must change. The molecular vibrations are invisible, and their precise nature unknown. Rankine's theory of molecular vortices assumes a law of vibration which has led to some useful results.

Since heat is energy, its laws are those generally applicable to energy, as laid down by Newton: it must have a commensurable value; it must be convertible into other forms of energy, and they to heat; and the equivalent of heat energy, expressed in mechanical energy units, must be constant and determinable by experiment.

4. Subdivisions of the Subject. The evolutions and absorptions of heat accompanying atomic combinations and molecular decompositions are the subjects of *thermochemistry*. The mutual relations of heat phenomena, with the consideration of the laws of heat transmission, are dealt with in general physics. The relations between heat and mechanical energy are included in the scope of *applied engineering thermodynamics*, which may be defined as the *science of the mechanical theory of heat*. While thermodynamics is thus apparently only a subdivision of that branch of physics which treats of heat, the relations which it considers are so important that it may be regarded as one of the two fundamental divisions of physics, which from this standpoint includes mechanics — dealing with the phenomena of ordinary masses — and thermodynamics — treating of the phenomena of molecules. **Thermodynamics is the science of energy.**

5. Applications of Thermodynamics. The subject has far-reaching applications in physics and chemistry. In its mechanical aspects, it deals

with matters fundamental to the engineer. After developing the general laws and dwelling briefly upon ideal processes, we are to study the conditions affecting the efficiency and capacity of air, gas, and steam engines and the steam turbine; together with the economics of air compression, distillation, refrigeration, and gaseous liquefaction. The ultimate engineering application of thermodynamics is in the saving of heat, an application which becomes attractive when viewed in its just aspect as a saving of money and a mode of conservation of our material wealth.

6. Temperature. A hot body, in common language, is one whose temperature is high, while a cold body is one low in temperature. Temperature, then, is a measure of the *hotness* of bodies. From a rise in temperature, we infer an accession of heat; or from a fall in temperature, a loss of heat.* Temperature is not, however, a satisfactory measure of quantities of heat. A pound of water at 200° contains very much more heat than a pound of lead at the same temperature; this may be demonstrated by successively cooling the bodies in a bath to the same final temperature, and noting the gain of heat by the bath. Furthermore, immense quantities of heat are absorbed by bodies in passing from the solid to the liquid or from the liquid to the vaporous conditions, without any change in temperature whatever. Temperature defines a *condition* of heat only. It is *a measure of the capacity of the body for communicating heat to other bodies*. Heat always passes *from* a body of relatively high temperature; it never passes of itself from a cold body to a hot one. Wherever two bodies of different temperatures are in thermal juxtaposition, an interchange of heat takes place; the cooler body absorbs heat from the hotter body, no matter which contains initially the greater *quantity* of heat, until the two are at the same temperature, or in *thermal equilibrium*. *Two bodies are at the same temperature when there is no tendency toward a transfer of heat between them*. Measurements of temperature are in general based upon arbitrary scales, standardized by comparison with some physically established "fixed" point. One of these fixed temperatures is that minimum at which pure water boils when under normal atmospheric pressure of 14.697 lb. per square inch; viz. 212° F. Another is the maximum temperature of melting ice at atmospheric pressure, which is 32° F. Our arbitrary scales of temperature cannot be expressed in terms of the fundamental physical units of length and weight.

7. Measurement of Temperature. Temperatures are measured by thermometers. The common type of instrument consists of a connected bulb and vertical tube, of glass, in which is contained a liquid. Any change in temperature affects

* "... the change in temperature is the thing observed and ... the idea of heat is introduced to account for the change. . . ."—Goodenough.

the volume of the liquid, and the portion in the tube consequently rises or falls. The expansion of solids or of gases is sometimes utilized in the design of thermometers. Mercury and alcohol are the liquids commonly used. The former freezes at -38° F. and boils at 675° F. The latter freezes at -203° F. and boils at 173° F. The mercury thermometer is, therefore, more commonly used for high temperatures, and the alcohol for low (2a).

8. Thermometric Scales. The **Fahrenheit** thermometer, generally employed by engineers in the United States and Great Britain, divides the space between the "fixed points" (Art. 6) into 180 equal degrees, freezing being at 32° and boiling at 212° . The **Centigrade** scale, employed by chemists and physicists (sometimes described as the Celsius scale), calls the freezing point 0° and the boiling point 100° . On the **Réaumur** scale, used in Russia and a few other countries, water freezes at 0° and boils at 80° . One degree on the Fahrenheit scale is, therefore, equal to $\frac{5}{9}^{\circ}$ C., or to $\frac{4}{9}^{\circ}$ R. In making transformations, care must be taken to regard the different zero point of the Fahrenheit thermometer. On all scales, temperatures below zero are distinguished by the minus (–) prefix.

The Centigrade scale is unquestionably superior in facilitating arithmetical calculations; but as most English papers and tables are published in Fahrenheit units, we must, for the present at least, use that scale of temperatures.

9. High Temperature Measurements. For measuring temperatures above 800° F., some form of **pyrometer** must be employed. The simplest of these is the *metallic pyrometer*, exemplifying the principle that different metals expand to different extents when heated through the same range of temperature. Bars of iron and brass are firmly connected at one end, the other ends being free. At some standard temperature the two bars are of the same length, and the indicator, controlled jointly by the two free ends of the bars, registers that temperature. When the temperature changes, the indicator is moved to a new position by the relative distortion of the free ends.

In the *Le Chatelier electric pyrometer*, a thermoelectric couple is employed. For temperatures ranging from 300° C. to 1500° C., one element is made of platinum, the other of a 10 per cent. alloy of platinum with rhodium. Any rise in temperature at the junction of the elements induces a flow of electric current, which is conducted by wires to a galvanometer, located in any convenient position. The expensive metallic elements are protected from oxidation by enclosing porcelain tubes. In the *Bristol* thermoelectric instrument, one element is of a platinum-rhodium alloy, the other of a cheaper metal. The electromotive force is indicated by a Weston millivoltmeter, graduated to read temperatures directly. The instrument is accurate up to 2000° F. The *electrical resistance pyrometer* is based on the law of increase of electrical resistance with increase of temperature. In Callendar's form, a coil of fine platinum wire is wound on a serrated mica frame. The instrument is enclosed in porcelain, and placed in the space the temperature

of which is to be ascertained. The resistance is measured by a Wheatstone bridge, a galvanometer, or a potentiometer, calibrated to read temperatures directly. Each instrument must be separately calibrated.

Optical pyrometers are based on the principle that the colors of bodies vary with their temperatures (2*b*). In the *Morse thermogage*, of this type, an incandescent lamp is wired in circuit with a rheostat and a millivoltmeter. The lamp is located between the eye and the object, and the current is regulated until the lamp becomes invisible. The temperature is then read directly from the calibrated millivoltmeter. The device is extensively used in hardening steel tools, and has been employed to measure the temperatures in steam boiler furnaces.

10. Cardinal Properties. A *cardinal* or *integral property* of a substance is any property which is fully *defined by the immediate state of the substance*. Thus, weight, length, specific gravity, are cardinal properties. On the other hand, cost is a non-cardinal property; the cost of a substance cannot be determined by examination of that substance; it depends upon the *previous history* of the substance. *Any two or three cardinal properties of a substance may be used as coördinates in a graphic representation of the state of the substance*. Properties not cardinal may not be so used, because such properties do not determine, nor are they determinable by, the present state of the substance. **The cardinal properties employed in thermodynamics are five or six in number.*** Three of these are **pressure, volume, and temperature**; pressure being understood to mean *specific pressure*, or uniform pressure per unit of surface, exerted by or upon the body, and volume to mean **volume per unit of weight**. The location of any point in space is fully determined by its three coördinates. Similarly, *any three cardinal properties may serve to fix the thermal condition of a substance*.

The first general principle of thermodynamics is that if two of the three named cardinal properties are known, these two enable us to calculate the third. This principle cannot be proved *à priori*; it is to be justified by its results in practice. Other thermodynamic properties than pressure, volume, and temperature conform to the same general principle (Art. 169); with these properties we are as yet unacquainted. A correlated principle is, then, that any *two* of the cardinal properties suffice to fully determine the state of the substance. For certain gases, the general principle may be expressed,

$$PV = (f)T,$$

* For gases, pressure, volume, temperature, internal energy, entropy; for wet vapors, dryness is another,

while for other gaseous fluids more complex equations (Art. 363) must be used. In general, these equations are, in the language of analytical geometry, equations to a surface. Certain vapors cannot be represented, as yet, by any single equation between P , V , and T , although corresponding values of these properties may have been ascertained by experiment. With other vapors, the pressure may be expressed as a function of the temperature, while the volume depends both upon the temperature and upon the proportion of liquid mingled with the vapor.

11. Preliminary Assumptions. The greater part of the subject deals with substances assumed to be *in a state of mechanical equilibrium*, all changes being made with infinite slowness. A second assumption is that no *chemical actions* occur during the thermodynamic transformation. In the third place, the substances dealt with are assumed to be so homogeneous, as to be in *uniform thermal condition* throughout: for example, the pressure property must involve equality of pressure in all directions; and this limits the consideration to the properties of liquids and gases.

The thermodynamics of solids is extremely complex, because of the obscure stresses accompanying their deformation (3). Kelvin (4) has presented a general analysis of the action of any homogeneous solid body homogeneously strained.

12. The Three Effects of Heat. Setting aside the obvious unclassified changes in pressure, volume, and temperature accompanying manifestations of heat energy, there are three known ways in which heat may be expended. They are:

(a) In a change of temperature of the substance.

(b) In a change of physical state of the substance.

(c) In the performance of external work by or upon the substance.

Denoting these effects by T , I , and W , then, for any transfer of heat H , we have the relation

$$H = T + I + W,$$

any of the terms of which expression may be negative. It should be quite obvious, therefore, that changes of temperature alone are insufficient to measure expenditures of heat.

Items (a) and (b) are sometimes grouped together as indications of a change in the **INTERNAL ENERGY** (symbol E) of the heated substance, the term being one of the first importance, which it is

essential to clearly apprehend. Items (*b*) and (*c*) are similarly sometimes combined as representing the **total work**.

13. The Temperature Effect. Temperature indications of heat activity are sometimes referred to as "sensible heat." The addition of heat to a substance may either raise or lower its temperature, in accordance with the fundamental equation of Art. 12.

The temperature effect of heat, from the standpoint of the mechanical theory, is due to a change in the *velocity of molecular motion*, in consequence of which the kinetic energy of that motion changes.

This effect is therefore sometimes referred to as **vibration work**. Clausius called it **actual energy**.

14. External Work Effect. The expansion of solids and fluids, due to the supply of heat, is a familiar phenomenon. Heat may cause either expansion or contraction, which, if exerted against a resistance, may suffice to perform mechanical work.

15. Changes of Physical State. Broadly speaking, such effects include all changes, other than those of temperature, within the substance itself. The most familiar examples are the change between the solid and the liquid condition, when the substance melts or freezes, and that between the liquid and the vaporous, when it boils or condenses; but *there are intermediate changes of molecular aggregation* in all material bodies which are to be classed with these effects under the general description, **disgregation work**. The mechanical theory assumes that in such changes the molecules are moved into new positions, with or against the lines of mutual attraction. These movements are analogous to the "partial raising or lowering of a weight which is later to be caused to perform work by its own descent. The potential energy of the substance is thus changed, and positive or negative work is performed against internal resisting forces."

When a substance changes its physical state, as from water to steam, it can be shown that a very considerable amount of **external work** is done, in consequence of the increase in volume which occurs, and which may be made to occur against a heavy pressure. This external work is, however, equivalent only to a very small proportion of the total heat supplied to produce evaporation, the balance of the heat having been expended in the performance of disgregation work.

The molecular displacements constituting disgregation work are exemplified in the phenomena of *solution*, and in the action of freezing mixtures (5).

16. Solid, Liquid, Vapor, Gas. Solid bodies are those which resist tendencies to change their form or volume. Liquids are those bodies which in all of their parts tend to preserve definite volume, and which are practically unresistant to influences tending to slowly change their figure. Gases are unresistant to slow changes in figure or to increases in volume. They tend to expand indefinitely so as to completely fill any space in which they are contained, no matter what the shape or the size of that space may be. Most substances have been observed in all three forms, under appropriate conditions; and all substances can exist in any of the forms. At this stage of the discussion, no essential difference need be drawn between a vapor and a gas. Formerly, the name vapor was applied to those gaseous substances which at ordinary temperatures were liquid, while a "gas" was a substance never observed in the liquid condition. Since all of the so-called "permanent" gases have been liquefied, this distinction has lost its force. A useful definition of a vapor as distinct from a true gas will be given later (Art. 380).

Under normal atmospheric pressure, there exist well-defined temperatures at which various substances pass from the solid to the liquid and from the liquid to the gaseous conditions. The temperature at which the former change occurs is called the **melting point** or **freezing point**; that of the latter is known as the **boiling point** or **temperature of condensation**.

17. Other Changes of State. Although the operation described as boiling occurs, for each liquid, at some definite temperature, there is an almost continual evolution of vapor from nearly all liquids at temperatures below their boiling points. Such "insensible" evaporation is with some substances non-existent, or at least too small in amount to permit of measurement: as in the instances of mercury at 32° F. or of sulphuric acid at any ordinary temperature. Ordinarily, a liquid at a given temperature continues to evaporate so long as its partial vapor pressure is less than the maximum pressure corresponding to its temperature. The interesting phenomenon of **sublimation** consists in the direct passage from the solid to the gaseous state. Such substances as camphor and iodine manifest this property. Ice and snow also pass directly to a state of vapor at temperatures far below the freezing point. There seem to be no quantitative data on the heat relations accompanying this change of state (see Art. 382 b).

18. Variations in "Fixed Points." Aside from the influence of pressure (Arts. 358, 603), various causes may modify the positions of the "fixed points" of the thermometric scale. Water may be cooled below 32° F. without freezing, if kept perfectly still. If free from air, water boils at 270–290° F. Minute particles of air are necessary to start evaporation sooner; their function is probably to aid in the diffusion of heat.

(1) Tyndall: *Heat as a Mode of Motion*. (2) Nichols and Franklin: *The Elements of Physics*, I, 161. (2a) *Heat Treatment of High Temperature Mercurial Thermometers*, by Dickinson; *Bulletin of the Bureau of Standards*, 2, 2. (2b) See the paper, *Optical Pyrometry*, by Waidner and Burgess, *Bulletin of the Bureau of Standards*, 1, 2. (3) See paper by J. E. Siebel: *The Molecular Constitution of*

Solids, in *Science*, Nov. 5, 1909, p. 654. (4) *Quarterly Mathematical Journal*, April, 1855. (5) Darling: *Heat for Engineers*, 208.

SYNOPSIS OF CHAPTER I

Heat is the universal source of motive power.

Theories of heat: the caloric theory — heat is matter; the mechanical theory — heat is molecular motion, mutually convertible with mechanical energy.

THERMOCHEMISTRY, THERMODYNAMICS.

Thermodynamics: the mechanical theory of heat; in its engineering applications, the science of heat-motor efficiency.

Heat intensity, temperature: definition of, measurement of; pyrometers.

Thermometric scales: Fahrenheit, Centigrade, Réaumur; fixed points and their variations.

Cardinal properties: pressure, volume, temperature; $PV=(f)T$.

Assumptions: uniform thermal condition; no chemical action; mechanical equilibrium.

Effects of heat: $H=T+I+W$; $T+I=E$ ="internal energy"; W =external work.

Changes of physical state, perceptible and imperceptible: I =disgregation work.

Solid, liquid, vapor, gas: melting point, boiling point; insensible evaporation; sublimation.

PROBLEMS

1. Compute the freezing points, on the Centigrade scale, of mercury and alcohol. (*Ans.*, mercury, -38.9° ; alcohol, -130.6° .)

2. At what temperatures, Réaumur, do alcohol and mercury boil? (*Ans.*, mercury, 285.8° ; alcohol, 62.7° .)

3. The normal temperature of the human body is 98.6° F. Express in Centigrade degrees. (*Ans.*, 37° C.)

4. At what temperatures do the Fahrenheit and Centigrade thermometers read alike? (*Ans.*, -40° .)

5. At what temperatures do the Fahrenheit and Réaumur thermometers read alike? (*Ans.*, -25.6° .)

6. Express the temperature -273° C. on the Fahrenheit and Réaumur scales. (*Ans.*, -459.4° F.: -218.4° R.)

CHAPTER II

THE HEAT UNIT: SPECIFIC HEAT: FIRST LAW OF THERMODYNAMICS

19. Temperature—Waterfall Analogy. The difference between temperature and quantity of heat may be apprehended from the analogy of a waterfall. Temperature is like the *head* of water; the energy of the fall depends upon the head, but cannot be computed without knowing at the same time the *quantity* of water. As waterfalls of equal height may differ in power, while those of equal power may differ in fall, so bodies at like temperatures may contain different quantities of heat, and those at unequal temperatures may be equal in heat contents.

20. Temperatures and Heat Quantities. If we mix equal weights of water at different temperatures, the resulting temperature of the mixture will be very nearly a mean between the two initial temperatures. If the original weights are unequal, then the final temperature will be nearer that initially held by the greater weight. The general principle of transfer is that

The loss of heat by the hotter water will equal the gain of heat by the colder.

Thus, 5 lb. of water at 200° mixed with 1 lb. at 104° gives 6 lb. at 184° ; the hotter water having lost 80 "pound-degrees," and the colder water having gained the same amount of heat. If, however, we mix the 5 lb. of hot water with 1 lb. of some other substance—say linseed oil—the resulting temperature will not be 184° , but 194.6° , if the initial temperature of the oil is 104° .

21. General Principles. Before proceeding, we may note, in addition to the principle just laid down, the following laws which are made apparent by the experiments described and others of a similar nature:

(a) In a homogeneous substance, the movement of heat accompanying a given change of temperature* is proportional to the weight of the substance.

(b) The movement of heat corresponding to a given change of

* Not only the amount, but the *method*, of changing the temperature must be fixed (Art. 57).

temperature is not necessarily the same for equal intervals at all parts of the thermometric scale; thus, water cooling from 200° to 195° does not give out exactly the same quantity of heat as in cooling from 100° to 95°.

(c) The loss of heat during cooling through a stated range of temperature is exactly equal to the gain of heat during warming through the same range.

22. The Heat Unit. Changes of temperature alone do not measure heat quantities, because heat produces other effects than that of temperature change. If, however, we place a body under "standard" conditions, at which these other effects, if not known, are at least constant, then we may define a unit of quantity of heat by reference to the change in temperature which it produces, understanding that there may be included perceptible or imperceptible changes of other kinds, not affecting the constancy of value of the unit.

The **British Thermal Unit** is that quantity of heat which is expended in raising the temperature of one pound of water (or in producing other effects during this change in temperature) from 62° to 63° F.*

To heat water over this range of temperature requires very nearly the same expenditure of heat as is necessary to warm it 1° at any point on the thermometric scale. In fact, some writers define the heat unit as that quantity of heat necessary to change the temperature from 39.1° (the temperature of maximum density) to 40.1°. Others use the ranges 32° to 33°, 59° to 60°, or 39° to 40°. The range first given is that most recently adopted.

23. French Units. The French or C. G. S. unit of heat is the **calorie**, the amount of heat necessary to raise the temperature of one kilogram of water 1° C. Its value is $2.2046 \times \frac{9}{5} = 3.96832$ B. t. u., and 1 B. t. u. = 0.251996 cal. The calorie is variously measured from 4° to 5° and from 14.5° to 15.5° C. The **gram-calorie** is the heat required to raise the temperature of one *gram* of water 1° C. The **Centigrade heat unit** measures the heat necessary to raise one *pound* of water 1° C. in temperature.

24. Specific Heat. Reference was made in Art. 20 to the different heat capacities of different substances, *e.g.* water and linseed oil. If we mix a stated quantity of water at a fixed temperature successively with equal weights of various materials, all initially at the same temperature, the final temperatures of the mixtures will all differ, indicating that a unit

* There are certain grounds for preferring that definition which makes the B. t. u. the $\frac{1}{180}$ part of the amount of heat required to raise the temperature of one pound of water at atmospheric pressure from the freezing point to the boiling point.

rise of temperature of unit weight of these various materials represents a different expenditure of heat in each case.

The property by virtue of which materials differ in this respect is that of **specific heat**, which may be defined as the quantity of heat necessary to raise the temperature of unit weight of a body through one degree.

The specific heat of water at standard temperature (Art. 22) is, measured in B. t. u., 1.0; generally speaking, its value is slightly variable, as is that of all substances.

Rankine's definition of specific heat is illustrative: "the specific heat of any substance is the ratio of the weight of water at or near 39.1° F. [62°–63° F.] which has its temperature altered one degree by the transfer of a given quantity of heat, to the weight of the other substance under consideration, which has its temperature altered one degree by the transfer of an equal quantity of heat."

25. Mixtures of Different Bodies. If the weights of a group of mixed bodies be X , Y , Z , etc., their specific heats x , y , z , etc., their initial temperatures t , u , v , etc., and the final temperature of the mixture be m , then we have the following as a general equation of thermal equilibrium, in which any quantity may be solved for as an unknown:

$$xX(t - m) + yY(u - m) + zZ(v - m) \dots = 0.$$

This illustrates the usual method of ascertaining the specific heat of any body. When all the specific heats are known, the loss of heat to surrounding bodies may be ascertained by introducing the additional term, $+R$, on the left-hand side of this equation. The solution will usually give a negative value for R , indicating that surrounding bodies have absorbed rather than contributed heat. The value of R will of course be expressed in heat units.

26. Specific Heat of Water. The specific heat of water, according to Rowland's experiments, decreases as the temperature is increased from 39.1° to 80° F., at which latter temperature it reaches a minimum value, afterward increasing (Art. 359, footnote). The variation in its value is very small. The approximate specific heat, 1.0, is high as compared with that of almost all other substances.

27. Problems Involving Specific Heat. The quantity of heat required to produce a given change of temperature in a body is equal to the weight of the body, multiplied by the range of temperature and by the specific heat.

Or, symbolically, using the notation of Art. 25,

$$H = xX(m - t).$$

If the body is cooled, then m , the final temperature, is less than t , and the sign of H is $-$; if the body is warmed, the sign of H is $+$, indicating a reception of heat.

28. Consequences of the Mechanical Theory. The Mechanical Equivalent of Heat. Even before Joule's formulation (Art. 2), Rumford's experiments had sufficed for a comparison of certain effects of heat with an expenditure of mechanical energy. The power exerted by the Bavarian horses used to drive his machinery is uncertain; but Alexander has computed the approximate relation to have been 847 foot-pounds = 1 B. t. u. (1), while another writer fixes the ratio at 1034, and Joule calculated the value obtained to have been 849.

Carnot's work, although based throughout on the caloric theory, shows evident doubts as to its validity. This writer suggested (1824) a repetition of Rumford's experiments, with provision for accurately measuring the force employed. Using a method later employed by Mayer (Art. 29) he calculated that "0.611 units of motive power" were equivalent to "550 units of heat"; a relation which Tyndall computes as representing 370 kilogram-meters per calorie, or 676 foot-pounds per B. t. u. Montgolfier and Seguin (1839) may possibly have anticipated Mayer's analysis.

29. Mayer's Calculation. This obscure German physician published in 1842 (2) his calculation of the mechanical equivalent of heat, based on the difference in the specific heats of air at constant pressure and constant volume, giving the ratio 771.4 foot-pounds per B. t. u. (Art. 72). This was a substantially correct result, though given little consideration at the time. Mayer had previously made rough calculations of equivalence, one being based on the rise of temperature occurring in the "beaters" of a paper mill.

30. Joule's Determination. Joule, in 1843, presented the first of his exhaustive papers on the subject. The usual form of apparatus employed has been shown in Fig. 1. In the appendix to his paper Joule gave 770 as the best value deducible from his experiments. In 1849 (3) he presented the figure for many years afterward accepted as final, viz. 772.

In 1878 an entirely new set of experiments led to the value 772.55, which Joule regarded as probably slightly too low. Experiments in 1857 had given the values 745, 753, and 766. Most of the tests were made with water at about 60° F. This, with the value of g at Manchester, where the experiments were made, involves slight corrections to reduce the results to standard conditions (4).

31. Other Investigators. Of independent, though uncertain, merit, were the results deduced by the Danish engineer, Colding, in 1843. His value of the equivalent is given by Tyndall as 638 (5). Helmholtz (1847) treated the matter of equivalence from a speculative standpoint. Assuming that "perpetual motion" is impossible, he contended that there *must* be a definite relation between heat energy and mechanical energy. As early as 1845, Holtzmann (6) had apparently

independently calculated the equivalence by Mayer's method. By 1847 the reality of the numerical relation had been so thoroughly established that little more was heard of the caloric theory. Clausius, following Mayer, in 1850 obtained wide circulation for the value 758 (7).

32. Hirn's Investigation. Joule had employed mechanical agencies in the heating of water. Hirn, in 1865 (8), described an experiment by which he transformed into heat the work expended in producing the impact of solid bodies. Two blocks, one of iron, the other of wood, faced with iron in contact with a lead cylinder, were suspended side by side as pendulums. The iron block was allowed to strike against the wood block and the rise in temperature of water contained in the lead cylinder was noted and compared with the computed energy of impact. The value obtained for the equivalent was 775.

Far more conclusive, though less accurate, results were obtained by Hirn by noting that the heat in the exhaust steam from an engine cylinder was less than that which was present in the entering steam. It was shown by Clausius that the heat which had disappeared was always roughly proportional to the work done by the engine, the average ratio of foot-pounds to heat units being 753 to 1. This was virtually a reversal of Joule's experiment, illustrating as it did the conversion of heat into work. It is the most striking proof we have of the equivalence of work and heat.

33. Recent Practice. In 1876 a committee of the British Association for the Advancement of Science reviewed critically the work of Joule, and as a mean value, derived from his best 60 experiments, recommended the use of the figure 774.1, which was computed to be correct within $\frac{1}{400}$. In 1879, Rowland, having conducted exact experiments on the specific heat of water, carefully redetermined the value of the equivalent by driving a paddle wheel about a vertical axis at fixed speed, in a vessel of water prevented from turning by counterbalance weights. The torque exerted by the paddle was measured. This permitted of a calculation of the energy expended, which was compared with the rise in temperature of the water. Rowland's value was **778**, with water at its maximum density. This was regarded as *possibly* slightly low (9). Since the date of Rowland's work, the subject has been investigated by Griffiths (10), who makes the value somewhat greater than 778, and by Reynolds and Moorby (11), who report the ratio 778 as the mean obtained for a range of temperature from 32° to 212° F. This they regard as possibly 1 or 2 foot-pounds too low.

34. Summary. The establishing of a definite **mechanical equivalent of heat** may be regarded as the foundation stone of thermodynamics. According to Merz (12), the anticipation of such an equivalent is due to Poncelet and Carnot; Rumford's name might be added. "The first philosophical generalizations were given by Mohr and Mayer; the first mathematical

treatment by Helmholtz; the first satisfactory experimental verification by Joule." The construction of the modern science on this foundation has been the work chiefly of Rankine, Clausius, and Kelvin.

35. First Law of Thermodynamics. Heat and mechanical energy are mutually convertible in the ratio of 778 foot-pounds to the British thermal unit.

This is a restricted statement of the general principle of the conservation of energy, a principle which is itself probably not susceptible to proof.

We have four distinct proofs of the first law :

(a) Joule's and Rowland's experiments on the production of heat by mechanical work.

(b) Hirn's observations on the production of work by the expenditure of heat.

(c) The computations of Mayer and others, from general data.

(d) The fact that the law enables us to predict thermal properties of substances which experiments confirm.

36. Wormell's Theorem. There cannot be two values of the mechanical equivalent of heat. Consider two machines, A and B , in the first of which work is transformed into heat, and in the second of which heat is transformed into work. Let J be the mechanical equivalent of heat for A , W the amount of work which it consumes in producing the heat Q ; then $W = JQ$ or $Q = W \div J$. Let this heat Q be used to drive the machine B , in which the mechanical equivalent of heat is, say K . Then the work done by B is $V = KQ = KW \div J$. Let this work be now expended in driving A . It will produce heat R , such that $JR = V$ or $R = V \div J$.* If this heat R be used in B , work will be done equal to KR ; but

$$KR = KV \div J = \left(\frac{K}{J}\right)^2 W.$$

Similarly, after n complete periods of operation, all parts of the machines occupying the same positions as at the beginning, the work ultimately done by B will be

$$\left(\frac{K}{J}\right)^n W.$$

If K is less than J , this expression will decrease as n increases; *i.e.* the system will tend continually to a state of rest, contrary to the first law of motion. If K be greater than J , then as n increases the work constantly increases, involving the assumed fallacy of perpetual motion. Hence K and J must be equal (13).

37. Significance of the Mechanical Equivalent. A very little heat is seen to be equivalent to a great deal of work. The heat used in raising the temperature of

* The demonstration assumes that the value of the mechanical equivalent is constant for a given machine.

one pound of water 100° represents energy sufficient to lift one ton of water nearly 39 feet. The heat employed to boil one pound of water initially at 32° F. would suffice to lift one ton 443 feet. The heat evolved in the combustion of one pound of hydrogen (62,000 B. t. u.) would lift one ton nearly five miles.

(1) *Treatise on Thermodynamics*, London, 1892. (2) Wöhler and Liebig's *Annalen der Pharmacie: Bemerkungen über die Kräfte der unbelebten Natur*, May, 1842. (3) *Phil. Trans.*, 1850. (4) Joule's *Scientific Papers*, Physical Society of London, 1884. (5) Probably quoted by Tyndall from a later article by Colding, in which this figure is given. Colding's original paper does not seem to be accessible. (6) *Ueber die Wärme und Elasticität der Gase und Dämpfe*, Mannheim, 1845. (7) Poggendorff, *Annalen*, 1850. (8) *Théorie Mécanique*, etc., Paris, 1865. (9) *Proc. Amer. Acad. Arts and Sciences*, New Series, VII, 1878-79. (10) *Phil. Trans. Roy. Soc.*, 1893. (11) *Phil. Trans.*, 1897. (12) *History of European Thought*, II, 137. (13) R. Wormell: *Thermodynamics*, 1886.

SYNOPSIS OF CHAPTER II

Heat and temperature: heat quantity vs. heat intensity.

Principles: (a) heat movement proportional to weight of substance; (b) temperature range does not accurately measure heat movement; (c) loss during cooling equals gain during warming, for identical ranges.

The British thermal unit: other units of heat quantity.

Specific heat: mixtures of bodies; quantity of heat to produce a given change of temperature; specific heat of water.

The mechanical equivalent of heat: early approximations. *First law of thermodynamics*: proofs; only one value possible; examples of the motive power of heat.

PROBLEMS

1. How many Centigrade heat units are equivalent to one calorie? (*Ans.*, 2.2046.)

2. Find the number of gram-calories in one B. t. u. (*Ans.*, 252.)

3. A mixture is made of 5 lb. of water at 200° , 3 lb. of linseed oil at 110° , and 22 lb. of iron at 220° (all Fahrenheit temperatures), the respective specific heats being 1.0, 0.3, and 0.12. Find the final temperature, if no loss occurs by radiation. (*Ans.*, 196.7° F.)

4. If the final temperature of the mixture in Problem 3 is 189° F., find the number of heat units lost by radiation. (*Ans.*, 65.7 B. t. u.)

5. Under what conditions, with the weights, temperatures and specific heats of Problem 3, might the final temperature exceed that computed?

6. How much heat is given out by $7\frac{1}{2}$ lb. of linseed oil in cooling from 400° F. to 32° F.? (*Ans.*, 828 B. t. u.)

7. In a heat engine test, each pound of steam leaves the engine containing 125.2 B.t.u. less heat than when it entered the cylinder. The engine develops 155 horse-power, and consumes 3160 lb. of steam per hour. Compute the value of the mechanical equivalent of heat. (*Ans.*, 775.7.)

8. A pound of good coal will evolve 14,000 B. t. u. Assuming a train resistance of 11 lb. per ton of train load, how far should one ton (2000 lb.) of coal burned in the locomotive without loss, propel a train weighing 2000 tons? If the locomotive weighs 125 tons, how high would one *pound* of coal lift it if fully utilized?

(*Ans.*, *a*, 187.2 miles; *b*, 43.5 ft.)

9. Find the number of kilogram-meters equivalent to one calorie. (1 meter = 39.37 in., 1 kilogram = 2.2046 lb.) (*Ans.*, 426.8.)

10. Transform the following formula (P being the pressure in kilograms per square meter, V the volume in cubic meters per kilogram, T the Centigrade temperature plus 273), to English units, letting the pressure be in pounds per square inch, the volume in cubic feet per pound, and the temperature that on the Fahrenheit scale plus 459.4, and eliminating coefficients in places where they do not appear in the original equation :

$$PV = 47.1 T - P(1 + 0.000002 P) \left[0.031 \left(\frac{373}{T} \right)^3 - 0.0052 \right].$$

$$\left(\text{Ans.}, PV = 0.5962 T - P(1 + 0.0014 P) \left(\frac{150,300,000}{T^3} - 0.0833 \right) \right)$$

CHAPTER III

LAWS OF GASES: ABSOLUTE TEMPERATURE: THE PERFECT GAS

38. Boyle's (or Mariotte's) Law. The simplest thermodynamic relations are those exemplified by the so-called permanent gases. Boyle (Oxford, 1662) and Mariotte (1676-1679) separately enunciated the principle that **at constant temperature the volumes of gases are inversely proportional to their pressures.** In other words, the product of the specific volume and the pressure of a gas at a given temperature is a constant. For air, which at 32° F. has a volume of 12.387 cubic feet per pound when at normal atmospheric pressure, the value of the constant is, *for this temperature,*

$$144 \times 14.7 \times 12.387 = 26,221.$$

Symbolically, if c denotes the constant for any given temperature,

$$pv = PV \quad \text{or,} \quad pv = c.$$

Figure 2 represents Boyle's law graphically, the ordinates being pressures per square foot, and the abscissas, volumes in cubic feet per pound. The curves are a series of equilateral hyperbolas,* plotted from the second of the equations just given, with various values of c .

39. Deviations from Boyle's Law. This experimentally determined principle was at first thought to apply rigorously to all true gases. It is now known to be not strictly correct for any of them, although very nearly so for air, hydrogen, nitrogen, oxygen, and some others. All gases may be liquefied, and all liquids may be gasified. When far from the point of liquefaction, gases conform with Boyle's law. When brought near the liquefying point by the combined influences of high pressure and low temperature, they depart widely from it. The four gases just mentioned ordinarily occur at far higher temperatures than those at which they will liquefy. Steam, carbon dioxide, ammonia vapor, and some other well-known gaseous substances which may easily be liquefied do not confirm the law even approximately. Conformity with Boyle's law may be regarded as a measure of the "perfectness" of a gas, or of its approximation to the truly gaseous condition.

* Referred to their common asymptotes as axes of P and V .

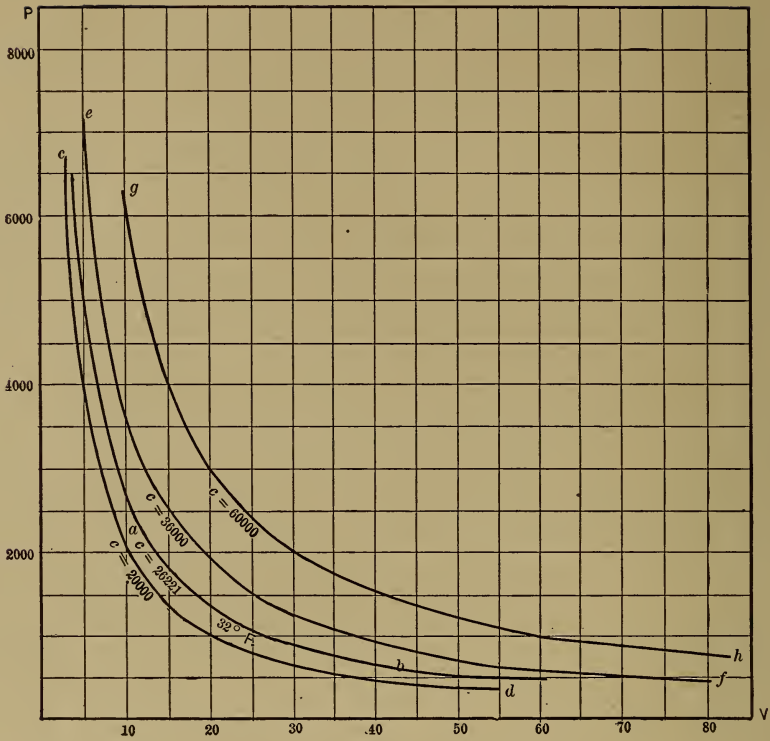

FIG. 2. Arts. 38, 91.— Boyle's Law.

40. Dalton's Law, Avogadro's Principle. Dalton has been credited (though erroneously) with the announcement of the law now known as that of Gay-Lussac or Charles (Art. 41). What is properly known as Dalton's law may be thus stated: **A mixture of gases having no chemical action on one another exerts a pressure which is the sum of the pressures which would be exerted by the component gases separately if each in turn occupied the containing vessel alone at the given temperature.**

The ratio of volumes, at standard temperature and pressure, in which two gases combine chemically is always a simple rational fraction ($\frac{1}{2}$, $\frac{2}{3}$, $\frac{3}{4}$, etc.). Taken in conjunction with the molecular theory of chemical combination, this law leads to the *principle of Avogadro* that all gases contain the same number of molecules per unit of volume, at the same temperature and pressure. Dalton's law has important thermodynamic relations (see Arts. 52 b, 382 b).

41. Law of Gay-Lussac or of Charles (1). Davy had announced that the coefficient of expansion of air was independent of the pressure. Gay-Lussac verified this by the apparatus shown in Fig. 3. He employed a glass tube with a large reservoir *A*, containing the air, which had been previously

dried. An index of mercury mn separated the air from the external atmosphere, while permitting it to expand. The vessel B was first filled with melting ice. Upon applying heat, equal intervals of temperature shown on the thermometer C were found to correspond with equal displacements of the index mn . When a pressure was applied on the atmospheric side of the index, the proportionate expansion of the air was shown to be still constant for equal intervals of temperature, and to be equal to that observed under atmospheric pressure. Precisely the same results were obtained with other gases. The expansion of dry air was found to be 0.00375, or $\frac{1}{267}$ of the volume at the freezing point, for each degree C. of rise of temperature. The law thus established may be expressed:

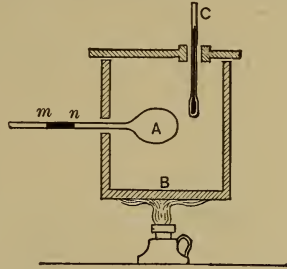

FIG. 3. Arts. 41, 48. — Verification of Charles' Law.

For all gases, and at any pressure, maintained constant, equal increments of volume accompany equal increments of temperature.

42. Increase of Pressure at Constant Volume. A second statement of this law is that all gases, when maintained at constant volume, undergo equal increases of pressure with equal increases of temperature.

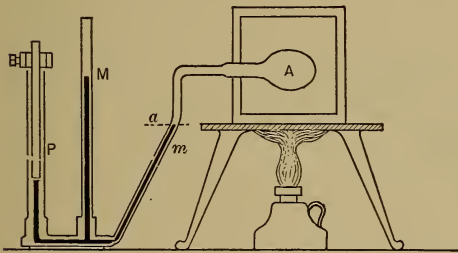

FIG. 4. Arts. 42, 48. — Coefficient of Pressure.

in which an iron rod is submerged to a sufficient depth to keep the level of the mercury in m at the marked point a , thus maintaining a constant volume of gas.

This is shown experimentally by the apparatus of Fig. 4. The glass bulb A contains the gas. It communicates with the open tube manometer Mm , which measures the pressure P is a tube containing mercury,

43. Regnault's Experiments. The constant 0.00375 obtained by Gay-Lussac was pointed out by Rudberg to be probably slightly inaccurate. Regnault, by employing four distinct methods, one of which was substantially that just described, determined accurately the coefficient of increase of pressure, and finally the coefficient of expansion at constant pressure, which for dry air was found to be 0.003665, or $\frac{1}{273}$, per degree C., of the volume at the freezing point.

44. Graphical Representation. In Fig. 5, let ab represent the volume of a pound of gas at 32° F. Let temperatures and volumes be represented, respectively, by ordinates and abscissas. According to Charles' Law, if the pressure be constant, the volumes and temperatures will increase proportionately; the volume ab increasing $\frac{1}{273}$ for each degree C. that the temperature is increased, and *vice versa*. The straight line cbe then represents the successive relations of volume and temperature as the gas

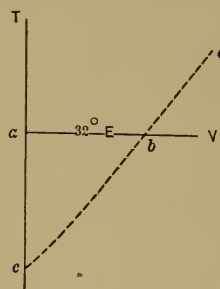

FIG. 5. Arts. 44, 84.—
Charles' Law.

is heated or cooled from the temperature at b . At the point e , where this line meets the aT axis, the volume of the gas will be zero, and its temperature will be 273° C., or 491.4° F., *below the freezing point*.

45. Absolute Zero. This temperature of -459.4° F. suggests the **absolute zero** of thermodynamics. All gases would liquefy or even solidify before reaching it. The lowest temperature as yet attained is about 450° F. below zero. The absolute zero thus experimentally conceived (a more strictly absolute scale is discussed later, Art. 156) furnishes a convenient starting point for the measurement of temperature, which will be employed, unless otherwise specified, in our remaining discussion. *Absolute temperatures are those in which the zero point is the absolute zero. Their numerical values are to be taken, for the present, at 459.4° greater than those of the corresponding Fahrenheit temperature.*

46. Symbolical Representation. The coefficients determined by Gay-Lussac, Charles, and Regnault were those for expansion from an initial volume of 32° F. If we take the volume at this temperature as unity, then letting T represent the absolute temperature, we have, for the volume at any temperature,

$$V = T \div 491.4.$$

Similarly, for the variation in pressure at constant volume, the initial pressure being unity, $P = T \div 491.4$. If we let a denote the value $1 \div 491.4$, the first expression becomes $V = aT$, and the second, $P = aT$. Denoting temperatures on the Fahrenheit scale by t , we obtain, for an initial volume v at 32° and any other volume V corresponding to the temperature t , produced without change of pressure,

$$V = v[1 + a(t - 32)].$$

Similarly, for variations in pressure at constant volume,

$$P = p[1 + a(t - 32)].$$

The value of a is experimentally determined to be very nearly the same for pressure changes as for volume changes ; the difference in the case of air being less than $\frac{1}{4}$ of one per cent. The temperature interval between the melting of ice and the boiling of water being 180° , the expansion of volume of a gas between those limits is $\frac{180 \times 1}{491.4} = 0.365$, whence Rankine's equation, originally derived from the experiments of Regnault and Rudberg,

$$\frac{PV}{pv} = 1.365,$$

in which P, V refer to the higher temperature, and p, v to the lower.

47. Deviations from Charles' Law. The laws thus enunciated are now known not to hold rigidly for any actual gases. For hydrogen, nitrogen, oxygen, air, carbon monoxide, methane, nitric oxide, and a few others, the disagreement is ordinarily very slight. For carbon dioxide, steam, and ammonia, it is quite pronounced. The reason for this is that stated in Art. 39. The first four gases named have expansive coefficients, not only almost unvarying, but almost exactly identical. They may be regarded as our most nearly perfect gases. For air, for example, Regnault found over a range of temperature of 180° F., and a range of pressure of from 109.72 mm. to 4992.09 mm., an extreme variation in the coefficients of only 1.67 per cent. For carbon dioxide, on the other hand, with the same range of temperatures and a decreased pressure range of from 785.47 mm. to 4759.03 mm., the variation was 4.72 per cent of the lower value (2).

48. The Air Thermometer. The law of Charles suggests a form of thermometer far more accurate than the ordinary mercurial instrument. If we allow air to expand without change in pressure, or to increase its pressure without change in volume, then we have by measurement of the volume or of the pressure respectively a direct indication of absolute temperature.

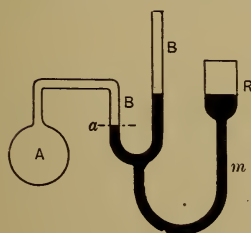

FIG. 6. Art. 48. — Air Thermometer.

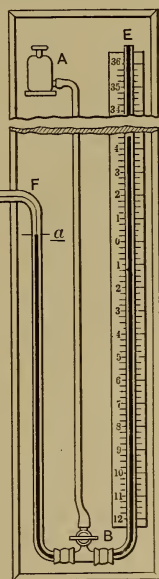
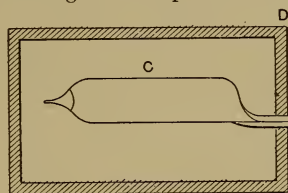

FIG. 7. Art. 48. — Preston Air Thermometer.

The apparatus used by Gay-Lussac (Fig. 3), or, equally, that shown in Fig. 4, is in fact an air thermometer, requiring only the establishment of a scale to fit it for practical use. A simple modern form of air thermometer is shown in Fig. 6. The

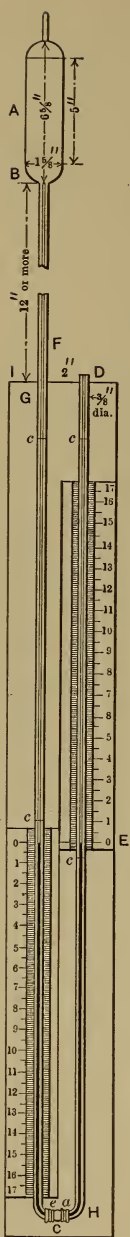

FIG. 8. Art. 48.
—Hoadley
Air Ther-
mometer.

bulb *A* contains dry air, and communicates through a tube of fine bore with the short arm of the manometer *BB*, by means of which the pressure is measured. The level of the mercury is kept constant at *a* by means of the movable reservoir *R* and flexible tube *m*. The Preston air thermometer is shown in Fig. 7. The air is kept at constant volume (at the mark *a*) by admitting mercury from the bottle *A* through the cock *B*. In the Hoadley air thermometer, Fig. 8, no attempt is made to keep the volume of air constant; expansion into the small tube below the bulb increasing the volume so slightly that the error is computed not to exceed 5° in a range of 600° (3).

49. Remarks on Air Thermometers. Following Regnault, the instrument is usually constructed to measure pressures at constant volume, using either nitrogen, hydrogen, or air as a medium. Only one "fixed point" need be marked, that of the temperature of melting ice. Having marked at 32° the atmospheric pressure registered at this temperature, the degrees are spaced so that one of them denotes an augmentation of pressure of $14.7 \div 491.4 = 0.0299$ lb. per square inch. It is usually more convenient, however, to determine the two fixed points as usual and subdivide the intervening distance into 180 equal degrees. The air thermometer readings differ to some extent from those of the most accurate mercurial instruments, principally because of the fact that mercury expands much less than any gas, and the modifying effect of the expansion of the glass container is therefore greater in its case. The air thermometer is itself not a perfectly accurate instrument, since air does not *exactly* follow Charles' law (Art. 47). The instrument is used for standardizing mercury thermometers, for direct measurements of temperatures below the melting point of glass (600 – 800° F.), as in Regnault's experiments on vapors; or, by using porcelain bulbs, for measuring much higher temperatures.

50. The Perfect Gas. If actual gases conformed precisely to the laws of Boyle and Charles, many of their thermal properties might be computed directly. The slowness of the deviations which actually occur suggests the notion of a perfect gas, which would exactly and invariably follow the laws,

$$PV = c, \quad V_p = aT, \quad P_v = aT.$$

Any deductions which might be made from these sym-
bolic expressions would of course be rigorously true only

for a perfect gas, which does not exist in nature. *The current thermodynamic method is, however, to investigate the properties of such a gas, modifying the results obtained so as to make them applicable to actual gases, rather than to undertake to express symbolically or graphically as a basis for computation the erratic behavior of those actual gases.* The error involved in assuming air, hydrogen, and other "permanent" gases to be perfect is in all cases too small to be of importance in engineering applications. Zeuner (4) has developed an "equation of condition" or "characteristic equation" for air which holds even for those extreme conditions of temperature and pressure which are here eliminated.

51. Properties of the Perfect Gas. The simplest definition is that the perfect gas is one which exactly follows the laws of Boyle and Charles. (Rankine's definition (5) makes conformity to Dalton's law the criterion of perfectness.) Symbolically, the perfect gas conforms to the law, readily deduced from Art. 50,

$$PV = RT,*$$

in which R is a constant and T the absolute temperature. Considering air as perfect, its value for R may be obtained from experimental data at atmospheric pressure and freezing temperature:

$$R = PV \div T = (14.7 \times 144 \times 12.387) \div 491.4 = 53.36 \text{ foot-pounds.}$$

For other gases treated as perfect, the value of R may be readily calculated when any corresponding specific volumes, pressures, and temperatures are known. Under the pressure and temperature just assumed, the specific volume of hydrogen is 178.83; of nitrogen, 12.75; of oxygen, 11.20. A useful form of the perfect gas equation may be derived from that just given by noting that $PV \div T = R$, a constant:

$$\frac{PV}{T} = \frac{pv}{t}.$$

52. Significance of R . At the standard pressure and temperature specified in Art. 51, the values of R for various gases are obviously proportional to their specific volumes or inversely proportional to their densities. This leads to the form of the characteristic equation some-

* At the temperature t_1 , let the pressure and volume be p_1, v_1 . If the gas were to expand at constant temperature, it would conform to Boyle's law, $p_1v_1 = c$, or $\frac{p_1v_1}{t_1} = c_1$. Let the pressure be raised to any condition p_2 while the volume remains v_2 , the temperature now becoming t_2 . Then by Charles' law, $\frac{p_2}{p_1} = \frac{t_2}{t_1}$, $p_2 = p_1 \frac{t_2}{t_1}$, $p_2v_2 = p_1v_1 \frac{t_2}{t_1} = c_1t_2$, where c_1 is a constant to which we give the symbol R .

times given, $PV = rT \div M$, in which M is the molecular weight and r a constant having the same value for all sensibly perfect gases.

TABLE— PROPERTIES OF THE COMMON GASES

	APPROXIMATE ATOMIC WEIGHT.	MOLECULAR WEIGHT.	SPECIFIC HEAT AT CONSTANT PRESSURE.	SYMBOL.
Hydrogen.....	1	2	3.4	H
Nitrogen.....	14	28	0.2438	N
Oxygen.....	16	32	0.217	O
Carbon dioxide.....	—	44	0.215	CO ₂
Alcohol.....	—	46	0.4534	C ₂ H ₆ O
Carbon monoxide.....	—	28	0.2438	CO
Ether.....	—	74	0.4797	(C ₂ H ₅) ₂ O
Ammonia.....	—	17	0.5	NH ₃
Sulphur dioxide.....	—	64	0.15	SO ₂
Chloroform.....	—	119	0.1567	CHCl ₃
Methane.....	—	16	0.5929	CH ₄
Olefiant gas.....	—	14	0.4040	CH ₂
Air.....	—	—	0.2375	—
Steam.....	—	18	0.5	H ₂ O

52a. Principles of Balloons.—A body is in vertical equilibrium in a fluid medium when its weight is equal to that of the fluid which it displaces. In a balloon, the weight supported is made up of (a) the car, envelope and accessories, and (b) the gas in the inflated envelope. The equation of equilibrium is

$$W = w + V(d - d'),$$

where W = weight in lbs., items (a) and (b), above;

w = weight of air displaced by the car, framework, etc., in lbs.;

V = volume of inflated envelope, cu. ft.;

d = density of surrounding air, lbs. per cu. ft.;

d' = density of gas in envelope, lbs. per cu. ft.

The term w is ordinarily negligible. The pressure of the gas in the envelope is only a small fraction of a pound above that of the atmosphere. When gas is vented from the balloon, the latter is prevented from collapsing by pumping air into one of the compartments (**ballonets**), so that the effect of venting is, practically speaking, to decrease the size of the envelope.

If the balloon is not in vertical equilibrium, then $W - w - V(d - d')$ is the net downward force, or negatively the upward pull on an anchor rope which holds the balloon down. A considerable variation in the

conditions of equilibrium arises from variations in the value of d . Atmospheric pressure varies with the altitude about as follows:

<i>Altitude in Miles.</i>	<i>Normal Atmospheric Pressure, Lbs. per Sq. In.</i>
0	14.7
$\frac{1}{4}$	14.02
$\frac{1}{2}$	13.33
$\frac{3}{4}$	12.66
1	12.02
$1\frac{1}{4}$	11.42
$1\frac{1}{2}$	10.88
2	9.80

52b. Mixtures of Gases. By Dalton's law (Art. 40), if w_1, w_2, w_3 be the weights of the constituents of a mixture at the state V (volume of entire mixture, *not* its specific volume), T, P ; and if the R values for these constituents be R_1, R_2, R_3 , then

$$p_1 = \frac{R_1 T w_1}{V}, \quad p_2 = \frac{R_2 T w_2}{V}, \quad p_3 = \frac{R_3 T w_3}{V},$$

$$P = p_1 + p_2 + p_3 = \frac{T}{V} (R_1 w_1 + R_2 w_2 + R_3 w_3).$$

If W be the weight of the mixture $= w_1 + w_2 + w_3$, then the equivalent R value for the mixture is

$$\frac{PV}{WT} = R = \frac{R_1 w_1 + R_2 w_2 + R_3 w_3}{W}.$$

Then, for example,

$$\frac{p_1}{P} = \frac{VR_1 T w_1}{RWT V} = \frac{R_1 w_1}{RW}, \text{ etc.}$$

If v_1, v_2, v_3 denote the actual volumes of several gases at the conditions P, T ; and w_1, w_2, w_3 , their weights, then $Pv_1 = w_1 R_1 T, Pv_2 = w_2 R_2 T, Pv_3 = w_3 R_3 T$,

$$W = w_1 + w_2 + w_3, \quad V = v_1 + v_2 + v_3,$$

$$PV = WRT, \quad \frac{v_1}{V} = \frac{PR_1 T w_1}{WRT P} = \frac{R_1 w_1}{WR}, \text{ etc.}$$

From expressions like the last we may deal with computations relating to mixed gases where the composition is given by volume. The equivalent molecular weight of the mixture is, of course, $\frac{r}{R}$ (Art. 52).

Dalton's law, like the other gas laws, does not exactly hold with any actual gas: but for ordinary engineering calculations with gases or even with superheated vapors the error is negligible.

53. Molecular Condition. The perfect gas is one in which the molecules move with perfect freedom, the distances between them being so great in comparison with their diameters that no mutually attractive forces are exerted. No performance of disgregation work accompanies changes of pressure or temperature.

Hirschfeld (6), in fact, defines the perfect gas as a substance existing in such a physical state that its constituent particles exert no interattraction. The coefficient of expansion, according to Charles' law, would be the exact reciprocal of the absolute temperature of melting ice, for all pressures and temperatures. Zeuner has shown (7) that as necessary consequences of the theory of perfect gases it can be proved that the product of the molecular weight and specific volume, at the same pressure and temperature, is constant for all gases; whence he derives Avogadro's principle (Art. 40). Rankine (8) has tabulated the physical properties of the "perfect gas."

54. Kinetic Theory of Gases. Beginning with Bernoulli in 1738, various investigators have attempted to explain the phenomena of gases on the basis of the kinetic theory, which is now closely allied with the mechanical theory of heat. According to the former theory, the molecules of any gas are of equal mass and like each other. Those of different gases differ in proportions or structure. The intervals between the molecules are relatively very great. Their tendency is to move with uniform velocity in straight lines. Upon contact, the direction of motion undergoes a change. In any homogeneous gas or mixture of gases, the mean energy due to molecular motion is the same at all parts. The pressure of the gas per unit of superficial area is proportional to the number of molecules in a unit of volume and to the average energy with which they strike this area. It is therefore proportional to the density of the gas and to the average of the squares of the molecular velocities. Temperature is proportional to the average kinetic energy of the molecules. The more nearly perfect the gas, the more infrequently do the molecules collide with one another. When a containing vessel is heated, the molecules rebound with increased velocity, and the temperature of the gas rises; when the vessel is cooled, the molecular velocity and the temperature are decreased. "When a gas is compressed under a piston in a cylinder, the particles of the gas rebound from the inwardly moving piston with unchanged velocity relative to the piston, but with increased actual velocity, and the temperature of the gas consequently rises. When a gas is expanded under a receding piston, the particles of the gas rebound with diminished actual velocity, and the temperature falls" (9).

Recent investigations in molecular physics have led to a new terminology but in effect serve to verify and explain the kinetic theory.

55. Application of the Kinetic Theory. Let w denote the actual molecular velocity. Resolve this into components x , y , and z , at right angles to one another. Then $w^2 = x^2 + y^2 + z^2$. Since the molecules move at random in all directions, $x = y = z$, and $w^2 = 3x^2$. Consider a single molecule, moving in an x direction back and forth between two limiting surfaces distant from each other d , the x component of the velocity of this particle being a . The molecule will make $(a \div 2d)$ oscillations per second. At each impact the velocity changes from $+a$ to $-a$, or by $2a$, and the momentum by $2am$, if m represents the mass of the molecule. The average rate of loss of momentum per single impact is $2am \times (a \div 2d) = ma^2 \div d$; and this is the average force exerted per second on each of the limiting surfaces. The total force exerted by all the molecules on these surfaces is then equal to $F = \frac{ma^2}{d}N = \frac{mx^2}{d}N = \frac{mw^2}{3d}N$, in which N is the total number of molecules

in the vessel. Let q be the area of the limiting surface. Then the force per unit of surface $= p = F \div q = \frac{mw^2}{3d} N \div q = \frac{mw^2 N}{3v}$, whence $pv = \frac{mw^2 N}{3} = \frac{W}{3g} \cdot w^2$, in which v is the volume of the gas $= qd$ and W is its weight in lbs. (10). See Art. 127 *a*.

56. Applications to Perfect Gases. Assuming that the absolute temperature is proportional to the average kinetic energy per molecule (Art. 54), this kinetic energy being $\frac{1}{2} mw^2$, then letting the mass be unity and denoting by R a constant relation, we have $pv = RT$. The kinetic theory is perfectly consistent with Dalton's law (Art. 40). It leads also to Avogadro's principle. Let two gases be present. For the first gas, $p = nmw^2 \div 3$, and for the second, $P = NMW^2 \div 3$. If $t = T$, $mw^2 = MW^2$, and if $p = P$, then $n = N$. If M denote the mass of the gas, $M = nN$, and $pv = Mw^2 \div 3$, or $w^2 = 3pv \div M$, from which the mean velocity of the molecules may be calculated for any given temperature.

For gases not perfect, the kinetic theory must take into account, (*a*) the effect of occasional collision of the molecules, and (*b*) the effect of mutual attractions and repulsions. The effect of collision is to reduce the average distance moved between impacts and to increase the frequency of impact and consequently the pressure. The result is much as if the volume of the containing vessel were smaller by a constant amount, b , than it really is. For v , we may therefore write $v - b$. The value of b depends upon the amount and nature of the gas.* The effect of mutual attractions is to slow down the molecules as they approach the walls. This makes the pressure less than it otherwise would be by an amount which can be shown to be inversely proportional to the square of the volume of the gas. For p , we therefore write $p + (a \div v^2)$, in which a depends similarly upon the quantity and nature of the gas. We have then the equation of Van der Waals,

$$\left(p + \frac{a}{v^2}\right)(v - b) = RT \quad (11).$$

(1) Cf. Verdet, *Leçons de Chimie et de Physique*, Paris, 1862. (2) *Rel. des Exp.*, I, 111, 112. (3) *Trans. A. S. M. E.*, VI, 282. (4) *Technical Thermodynamics* (Klein tr.), II, 313. (5) "A perfect gas is a substance in such a condition that the total pressure exerted by any number of portions of it, against the sides of a vessel in which they are inclosed, is the sum of the pressures which each such portion would exert if enclosed in the vessel separately at the same temperature." — *The Steam Engine*, 14th ed., p. 226. (6) *Engineering Thermodynamics*, 1907. (7) *Op. cit.*, I, 104–107. (8) *Op. cit.*, 593–595. (9) Nichols and Franklin, *The Elements of Physics*, I, 199–200. (10) *Ibid.*, 199; Wormell, *Thermodynamics*, 157–161. (11) *Over de Continuïteit van den Gas en Vloeistoestand*, Leiden, 1873, 76; tr. by Roth, Leipsic, 1887.

SYNOPSIS OF CHAPTER III

Boyle's law, $pv = PV$: deviations.

Dalton's law, Avogadro's principle.

Law of Gay-Lussac or of Charles: increase of volume at constant pressure; increase of pressure at constant volume; values of the coefficient from 32° F.; deviations with actual gases.

* Strictly, it depends upon the space between the molecules; but Richards suggests (*Science*, XXXIV, N. S., 878), that it may vary with the pressure and the temperature.

The absolute zero: $-459.4^{\circ} F.$, or $491.4^{\circ} F.$ below the freezing point.

Air thermometers: Preston's; Hoadley's; calibration; gases used.

The perfect gas, $\frac{pv}{t} = \frac{PV}{T}$; definitions; properties; values of R ; absence of intermolecular action; the kinetic theory; development of the law $PV = RT$ therefrom; conformity with Avogadro's principle; molecular velocity.

Table; the common gases;

$$\text{Constants for gas mixtures: } R = \frac{R_1 w_1 + R_2 w_2 \dots}{W}$$

Balloons: weight = weight of fluid displaced.

The Van der Waals equation for imperfect gases:

$$\left(p + \frac{a}{v^2}\right)(v - b) = RT.$$

PROBLEMS

- Find the volume of one pound of air at a pressure of 100 lb. per square inch, the temperature being $32^{\circ} F.$, using Boyle's law only. (*Ans.*, 1.821 cu. ft.)
- From Charles' law, find the volume of one pound of air at atmospheric pressure and $72^{\circ} F.$ (*Ans.*, 13.4 cu. ft.)
- Find the pressure exerted by one pound of air having a volume of 10 cubic feet at $32^{\circ} F.$ (*Ans.*, 18.2 lb. per sq. in.)
- One pound of air is cooled from atmospheric pressure at constant volume from $32^{\circ} F.$ to $-290^{\circ} F.$ How nearly perfect is the vacuum produced? (*Ans.*, 65.5%)
- Air at 50 lb. per square inch pressure at the freezing point is heated at constant volume until the temperature becomes $2900^{\circ} F.$ Find its pressure after heating. (*Ans.*, 341.8 lb. per sq. in.)
- Five pounds of air occupy 50 cubic feet at a temperature of $0^{\circ} F.$ Find the pressure. (*Ans.*, 17.03 lb. per sq. in.)
- Find values of R for hydrogen, nitrogen, oxygen.
(*Ans.*, for hydrogen, 770.3; for nitrogen, 54.9; for oxygen, 48.2.)
- Find the volume of three pounds of hydrogen at 15 lb. pressure per square inch and $75^{\circ} F.$ (*Ans.*, 571.8 cu. ft.)
- Find the temperature of 2 ounces of hydrogen contained in a 1-gallon flask and exerting a pressure of 10,000 lb. per square inch. (*Ans.*, $1536^{\circ} F.$)
- Compute the value of r (Art. 52). (*Ans.*, 1538 to 1544.)
- Find the mean molecular velocity of 1 lb. of air (considered as a perfect gas) at atmospheric pressure and $70^{\circ} F.$ (*Ans.*, 1652 ft. per sec.)
- How large a flask will contain 1 lb. of nitrogen at 3200 lb. pressure per square inch and $70^{\circ} F.$? (*Ans.*, 0.0631 cu. ft.)
- A receiver holds 10 lb. of oxygen at $20^{\circ} C.$ and under 200 lb. pressure per square inch. What weight of air will it hold at $100^{\circ} F.$ and atmospheric pressure?
- For an oxy-hydrogen light, there are to be stored 25 lb. of hydrogen and 200 lb. of oxygen. The pressures in the two tanks must not exceed 500 lb. per square inch at $110^{\circ} F.$ Find their volumes.
- A receiver containing air at normal atmospheric pressure is exhausted until the pressure is 0.1 inch of mercury, the temperature remaining constant. What per

cent of the weight of air has been removed? (14.697 lb. per sq. in. = 29.92 ins. mercury.)

16. At sea level and normal atmospheric pressure, a 60,000 cu. ft. hydrogen balloon is filled at 14.75 lb. pressure. The temperature of the hydrogen is 70° F.; that of the external air is 60° F. The envelope, car, machinery, ballast, and occupants weigh 3500 lb. Ignoring the term w , Art. 52a, what is the upward pull on the anchor rope?

17. How much ballast must be discharged from the balloon in Prob. 16 in order that when liberated it may rise to a level of vertical equilibrium at an altitude of 2 miles?

18. In Problem 17, there are vented from the balloon, while it is at the 2-mile altitude, 10 per cent of its gas contents. If the ballonet which has been vented is kept constantly filled with air at a pressure just equal to that of the external atmosphere, to what approximate elevation will the balloon descend? What is the net amount of force available for accelerating downward at the moment when descent begins?

19. In Problem 17, while at the 2-mile level, the temperature of the hydrogen becomes 60° and that of the surrounding air 0°, without change in either internal or external pressure. What net amount of ascending or descending force will be caused by these changes? How might this be overcome?

20. In a mixture of 5 lb. of air with 16 lb. of steam, at a pressure of 50 lb. per square inch at 70° F., what is the value of R for the mixture? What is its equivalent molecular weight? The difference of k and l ? The partial pressure due to air only?

21. A mixed gas weighing 4 lb. contains, by volume, 35 per cent of CO, 16 per cent of H and 3 per cent of CH₄, the balance being N. The pressure is 50 lb. per square inch and the temperature 100° F. Find the value of R for the mixture, the partial pressure due to each constituent, and the percentage composition by weight.

CHAPTER IV

THERMAL CAPACITIES: SPECIFIC HEATS OF GASES: JOULE'S LAW

57. Thermal Capacity. The definition of specific heat given in Art. 24 is, from a thermodynamic standpoint, inadequate. *Heat produces other effects than change of temperature.* A definite movement of heat can be estimated only when all of these effects are defined. For example, the quantity of heat necessary to raise the temperature of air one degree in a constant volume air thermometer is much less than that used in raising the temperature one degree in the constant pressure type. The specific heat may be satisfactorily defined only by referring to the condition of the substance during the change of temperature. *Ordinary specific heats assume constancy of pressure,*—that of the atmosphere,—while the volume increases with the temperature in a ratio which is determined by the coefficient of expansion of the material. A specific heat determined in this way—as are those of solids and liquids generally—is the **specific heat at constant pressure.**

Whenever the term "specific heat" is used without qualification, this particular specific heat is intended. Heat may be absorbed during changes of either pressure, volume, or temperature, while some other of these properties of the substance is kept constant. For a specific change of property, the amount of heat absorbed represents a **specific thermal capacity.**

58. Expressions for Thermal Capacities. If H represents heat absorbed, c a constant specific heat, and $(T-t)$ a range of temperature, then, by definition, $H = c(T-t)$ and $c = H \div (T-t)$. If c be variable, then $H = \int cdT$ and $c = dH \div dT$. If in place of c we wish to denote the **specific heat at constant pressure** (k), or that at **constant volume** (l), we may apply subscripts to the differential coefficients; thus,

$$k = \left(\frac{\delta H}{\delta T} \right)_P \quad \text{and} \quad l = \left(\frac{\delta H}{\delta T} \right)_V,$$

the subscripts denoting the property which remains constant during the change in temperature.

We have also the thermal capacities,

$$\left(\frac{\delta H}{\delta V} \right)_T, \quad \left(\frac{\delta H}{\delta P} \right)_T, \quad \left(\frac{\delta H}{\delta P} \right)_V, \quad \left(\frac{\delta H}{\delta V} \right)_P$$

The first of these denotes the amount of heat necessary to increase the specific volume of the substance by unit volume, while the temperature remains constant;

this is known as the latent heat of expansion. It exemplifies absorption of heat without change of temperature. No names have been assigned for the other thermal capacities, but it is not difficult to describe their significance.

59. Values of Specific Heats. It was announced by Dulong and Petit that the specific heats of substances are inversely as their chemical equivalents. This was shown later by the experiments of Regnault and others to be approximately, though not absolutely, correct. Considering metals in the solid state, the product of the specific heat by the atomic weight ranges at ordinary temperatures from 6.1 to 6.5. This nearly constant product is called the atomic heat. Determination of the specific heat of a solid metal, therefore, permits of the approximate computation of its atomic weight. Certain non-metallic substances, including chlorine, bromine, iodine, selenium, tellurium, and arsenic, have the same atomic heat as the metals. The molecular heats of compound bodies are equal to the sums of the atomic heats of their elements; thus, for example, for common salt, the specific heat 0.219, multiplied by the molecular weight, 58.5, gives 12.8 as the molecular heat; which, divided by 2, gives 6.4 as the average atomic heat of sodium and chlorine; and as the atomic heat of sodium is known to be 6.4, that of chlorine must also be 6.4 (1).

60. Volumetric Specific Heat. Since the specific volumes of gases are inversely as their molecular weights, it follows from Art. 59 that the quotient of the specific heat by the specific volume is practically constant for ordinary gases. In other words, the specific heats of equal volumes are equal. The specific heats of these gases are directly proportional to their specific volumes and inversely proportional to their densities, approximately. Hydrogen must obviously possess the highest specific heat of any of the gases.

61. Mean, "Real," and "Apparent" Specific Heats. Since all specific heats are variable, the values given in tables are mean values ascertained over a definite range of temperature. The mean specific heat, adopting the notation of Art. 58, is $c = H \div (T - t)$; while the true specific heat, or specific heat "at a point," is the limiting value $c = dH \div dT$.

Rankine discusses a distinction between the real and apparent specific heats; meaning by the former, the rate of heat absorption necessary to effect changes of temperature alone, without the performance of any disgregation or external work; and by the latter, the observed rate of heat absorption, effecting the same change of temperature, but simultaneously causing other effects as well. For example, in heating water at constant pressure from 62° to 63° F., the apparent specific heat is 1.0 (definition, Art. 22). To compute the real specific heat, we must know the external work done by reason of expansion against the constant pressure, and the disgregation work which has readjusted the molecules. Deducting from 1.0 the heat equivalent to these two amounts of work, we have the real specific heat, that which is used solely for making the substance hotter. Specific heats determined by experiment are always apparent; the real specific heats are known only by computation (Art. 64).

62. Specific Heats of Gases. Two thermal capacities of especial importance are used in calculations relating to gases. The first is the *specific heat at constant pressure*, k , which is the amount of heat necessary to raise the temperature one degree while the pressure is kept constant; the other, the *specific heat at constant volume*, l , or the amount of heat necessary to raise the temperature one degree while the volume is kept constant.

63. Regnault's Law. As a result of his experiments on a large number of gases over rather limited ranges of temperature, Regnault announced that the specific heat of any gas at constant pressure is constant. This is now known not to be rigorously true of even our most nearly perfect gases. It is not even approximately true of those gases when far from the condition of perfectness, *i.e.* at low temperatures or high pressures. At very high temperatures, also, it is well known that specific heats rapidly increase. This particular variation is perhaps due to an approach toward that change of state described as *dissociation*. When near any change of state, — combustion, fusion, evaporation, dissociation, — every substance manifests erratic thermal properties. The specific heat of carbon dioxide is a conspicuous illustration. Recent determinations by Holborn and Henning (2) of the mean specific heats between 0° and x° C. give, for nitrogen, $k = 0.255 + 0.000019x$; and for carbon dioxide, $k = 0.201 + 0.0000742x - 0.00000018x^2$; while for steam, heated from 110° to x° C., $k = 0.4669 - 0.0000168x + 0.00000044x^2$. The specific heats of solids also vary. The specific heats of substances in general increase with the temperature. Regnault's law would hold, however, for a perfect gas; in this, the specific heat would be constant under all conditions of temperature. For our "permanent" gases, the specific heat is practically constant at ordinary temperatures.

The table in Art. 52 shows that in general the specific heats at constant pressure vary inversely as the molecular weights. Carbon dioxide, sulphur dioxide, ammonia, and steam (which are highly imperfect gases) vary most widely from this law.

64. The Two Specific Heats. When a gas is heated at constant pressure, its volume increases against that pressure, and external work is done in consequence. The external work may be computed by multiplying the pressure by the change in volume. When heated at constant volume, no external work is done; no movement is made against an external resistance. If the gas be perfect, then, under this condition, no disgregation work is done; and the specific heat at constant volume is a *true* specific heat, according to Rankine's distinction (Art. 61). The specific heat at constant pressure is, however, the one commonly determined by experiment. The numerical values of the two specific heats must, in a perfect gas, differ by the heat equivalent to the external work done during heating at constant pressure. Under certain conditions, — as with water at its

maximum density,—no external work is done when heating at constant pressure; and at this state the two specific heats are equal, if we ignore possible differences in the disgregation work.

65. Difference of Specific Heats. Let a pound of air at 32° F. and atmospheric pressure be raised 1° F. in temperature, at constant pressure. It will expand $12.387 \div 491.4 = 0.02521$ cu. ft., against a resistance of $14.7 \times 144 = 2116.8$ lb. per square foot. The external work which it performs is consequently $2116.8 \times 0.02521 = 53.36$ foot-pounds. A general expression for this external work is $W = PV \div T$; and as from Art. 51 the quotient $PV \div T$ is a constant and equal to R , then W is a constant for each particular gas, and equivalent in value to that of R for such gas. The value of W for air, expressed in heat units, is $53.36 \div 778 = 0.0686$. If the specific heat of air at constant pressure, as experimentally determined, be taken at 0.2375 , then the specific heat at constant volume is $0.2375 - 0.0686 = 0.1689$, air being regarded as a perfect gas.

66. Derivation of Law of Perfect Gas. Let a gas expand at constant pressure P from the condition of absolute zero to any other condition V, T . The total external work which it will have done in consequence of this expansion is PV . The work done per degree of temperature is $PV \div T$. But, by Charles' law, this is constant, whence we have $PV = RT$. The symbol R of Art. 51 thus represents the external work of expansion during each degree of temperature increase (3).

67. General Case. The difference of the specific heats, while constant for any gas, is different for different gases, because their values of R differ. But since values of R are proportional to the specific volumes of gases (Art. 52), the difference of the volumetric specific heats is constant for all gases. Thus, let k, l be the two specific heats, per pound, of air. Then $k - l = r$. Let d be the density of the air; then, $d(k - l)$ is the difference of the volumetric specific heats. For any other gas, we have similarly, $K - L = R$ and $D(K - L)$; but, from Art. 52 $R : r :: d : D$, or $R = rd \div D$. Hence, $K - L = rd \div D = (k - l)(d \div D)$, or $D(K - L) = d(k - l)$. The difference of the volumetric specific heats is for all gases equal approximately to 0.0055 B. t. u. (Compare Art. 60.)

68. Computation of External Work. The value of R given in Art. 52 and Art. 65 is variously stated by the writers on the subject, on account of the slight uncertainty which exists regarding the exact values of some of the constants used in computing it. The differences are too small to be of consequence in engineering work.

69. Ratio of Specific Heats. The numerical ratio between the two specific heats of a sensibly perfect gas, denoted by the symbol γ , is a constant of prime importance in thermodynamics.

For air, its value is $0.2375 \div 0.1689 = 1.4+$. Various writers, using other fundamental data, give slightly different values (4). The best direct experiments (to be described later) agree with that here given within a narrow margin. For hydrogen, Lummer and Pringsheim (5) have obtained the value 1.408; and for oxygen, 1.396. For carbon dioxide, a much less perfect gas than any of these, these observers make the value of y , 1.2961; while Dulong obtained 1.338. The latter obtained for carbon monoxide 1.428. The mean value for the "permanent" gases is close to that for air, viz.,

$$y = 1.4+.$$

The value of y is about the same for all common gases, and is practically independent of the temperature or the pressure.

From Arts. 59, 60, 65, we have, letting m denote chemical equivalents and V specific volumes,

$$k = \frac{a}{m} = aV, \quad R = bV,$$

$$l = (a-b)V, \quad y = \frac{a}{a-b},$$

where a and b are constants having the same value for all gases.

70. Relations of R and y . A direct series of relations exists between the two specific heats, their ratio, and their difference. If we denote the specific heats by k and l , then in proper units,

$$k - l = R. \quad l = k - R. \quad \frac{k}{l} = y. \quad \frac{k}{k - R} = y.$$

$$\left(\text{For air, this gives } \frac{0.2375}{0.2375 - \frac{53.36}{778}} = 1.402. \right)$$

$$k = ky - yR. \quad ky - k = yR. \quad k = R \frac{y}{y-1}.$$

$$l = R \frac{1}{y-1}. \quad R = k \frac{y-1}{y} = l(y-1).$$

71. Rankine's Prediction of the Specific Heat of Air. The specific heat of air was approximately determined by Joule in 1852. Earlier determinations were unreliable. Rankine, in 1850, by the use of the relations just cited, closely approximated the result obtained experimentally by Regnault three years later. Using the values $y = 1.4$, $R = 53.15$, Rankine obtained

$$k = R \frac{y}{y-1} = (53.15 \div 772) \times (1.4 \div 0.4) = 0.239.$$

Regnault's result was 0.2375.

72. Mayer's Computation of the Mechanical Equivalent of Heat. Reference was made in Art. 29 to the computation of this constant prior to the date of Joule's conclusive experiments. The method is substantially as follows: a cylinder and piston having an area of one square foot, the former containing one cubic foot, are assumed to hold air at 32° F., which is subjected to heat. The piston is balanced, so that the pressure on the air is that of the atmosphere, or 14.7 lb. per square inch; the total pressure on the piston being, then, $144 \times 14.7 = 2116.8$ lb. While under this pressure, the air is heated until its temperature has increased 491.4° . The initial volume of the air was by assumption one cubic foot, whence its weight was $1 \div 12.387 = 0.0811$ lb. The heat imparted was therefore $0.0811 \times 0.2375 \times 491.4 = 9.465$ B. t. u. The external work was that due to doubling the volume of the air, or $1 \times 14.7 \times 144 = 2116.8$ foot-pounds. The piston is now fixed rigidly in its original position, so that the volume cannot change, and no external work can be done. The heat required to produce an elevation of temperature of 491.4° is then $0.0811 \times 0.1689 \times 491.4 = 6.731$ B. t. u. The difference of heat corresponding to the external work done is 2.734 B. t. u., whence the mechanical equivalent of heat is $2116.8 \div 2.734 = 774.2$ foot-pounds.

73. Joule's Experiment. One of the crucial experiments of the science was conducted by Joule about 1844, after having been previously attempted by Gay-Lussac.

Two copper receivers, *A* and *B*, Fig. 9, were connected by a tube and stopcock, and placed in a water bath.

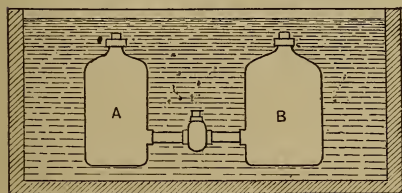

FIG. 9. Arts. 73, 80. — Joule's Experiment.

to a pressure of 22 atmospheres, while a vacuum was maintained in *B*. When the stopcock was opened, the pressure in each receiver became 11 atmospheres, and the temperature of the air and of the water bath remained practically

unchanged. This was an instance of expansion *without the performance of external work*; for there was *no resisting pressure* against the augmentation of volume of the air.

74. Joule's and Kelvin's Porous Plug Experiment. Minute observations showed that a slight change of temperature occurred in the water bath. Joule and Kelvin, in 1852, by their celebrated "porous plug" experiments, ascertained the exact amount of this change for various gases. In all of the permanent gases the change was very small; in some cases the temperature increased, while in others it decreased; and the inference is justified that in a perfect gas there would be no change of temperature (Art. 156).

75. Joule's Law. The experiments led to the principle that when a perfect gas expands without doing external work, and without receiving or discharging heat, the temperature remains unchanged and no disgregation work is done. A clear appreciation of this law is of fundamental importance. Four thermal phenomena might have occurred in Joule's experiment: a movement of heat, the performance of external work, a change in temperature, or work of disgregation. From Art. 12, these four effects are related to one another in such manner that their summation is zero; ($H = T + I + W$). By means of the water bath, which throughout the experiment had the same temperature as the air, the movement of heat to or from the air was prevented. By expanding into a vacuum, the performance of external work was prevented. The two remaining items must then sum up to zero, *i.e.* the temperature change and the disgregation work. But the temperature did not change; consequently the amount of disgregation work must have been zero.

76. Consequences of Joule's Law. In the experiment described, the pressure and volume changed without changing the internal energy. No disgregation work was done, and the temperature remained unchanged. Considering pressure, volume, and temperature as three cardinal thermal properties, internal energy is then independent of the pressure or volume and depends on the temperature only, in any perfect gas. It is thus itself a cardinal property, in this case, a function of the temperature. "A change of pressure and volume of a perfect gas not associated with change of temperature does not alter the internal energy. In any change of temperature, the change of internal energy is independent of the relation of pressure to volume during the operation; it depends only on the amount by which the temperature has been changed" (6). The gas tends to cool in expanding, but this effect is "exactly compensated by the heat which

is disengaged through the friction in the connecting tube and the impacts which destroy the velocities communicated to the particles of gas while it is expanding" (7). *There is practically no disgregation work in heating a sensibly perfect gas; all of the internal energy is evidenced by temperature alone.* When such a gas passes from one state to another in a variety of ways, the external work done varies; but if from the total movement of heat the equivalent of the external work be deducted, then the remainder is always the same, no matter in what way the change of condition has been produced. Instead of $H = T + I + W$, we may write: $H = T + W$.

77. Application to Difference of Specific Heats. The heat absorbed during a change in temperature at constant pressure being $H = k(T - t)$, and the external work during such a change being $W = P(V - v) = R(T - t)$, the gain of internal energy must be

$$H - W = (k - R)(T - t).$$

The heat absorbed during the same change of temperature at constant volume is $H = l(T - t)$. Since in this case no external work is done, the whole of the heat must have been applied to increasing the internal energy. But, according to Joule's law, the change of internal energy is shown by the temperature change alone. In whatever way the temperature is changed from T to t , the gain of internal energy is the same. Consequently,

$$(k - R)(T - t) = l(T - t) \text{ and } k - R = l,$$

a result already suggested in Art. 65.

78. Discussion of Results. The greater value of the specific heat at constant pressure is due solely to the performance of external work during the change in temperature. The specific heat at constant volume is a *real* specific heat, in the case of a perfect gas; no external work is done, and the internal energy is increased only by reason of an elevation of temperature. There is no disgregation work. All of the heat goes to make the substance hot. So long as no external work is done, it is not necessary to keep the gas at constant volume in order to confirm the lower value for the specific heat; no more heat is required to raise the temperature a given amount when the gas is allowed to expand than when the volume is maintained constant. For any gas in which the specific heat at constant volume is constant, Joule's law is inductively established; for no external work is done, and temperature alone measures the heat absorption at any point on the thermometric scale. *If a gas is allowed to expand, doing external work at constant temperature, then, since no change of inter-*

nal energy occurs, it is obvious from Art. 12 that *the external work is equal to the heat absorbed*. Briefly, the important deduction from Joule's experiment is that item (b), Art. 12, may be ignored when dealing with sensibly perfect gases.

79. Confirmatory Experiment. By a subsequent experiment, Joule showed that when a gas expands so as to perform external work, heat *disappears* to an extent proportional to the work done. Figure 10 illustrates the apparatus. A receiver *A*, containing gas compressed to two atmospheres, was placed in the calorimeter *B* and connected with the gas holder *C*, placed over a water tank. The gas passed from *A* to *C* through the coil *D*, depressed the water in the gas holder, and divided itself between the two vessels, the pressure falling to that of one atmosphere. The work done was computed from the augmentation of volume shown by driving down the water in *C* against atmospheric pressure; and the heat lost was ascertained from the fall of temperature of the water. If the temperature of the air were caused to remain constant throughout the experiment, then the work done at *C* would be precisely equivalent to the heat given up by the water. If the temperature of the air were caused to remain constantly the same as that of the water, then $H = 0 = T + I + W$, $(T + I) = -W$, or internal energy would be given up by the air, precisely equivalent in amount to the work done in *C*.

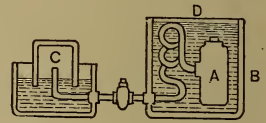

FIG. 10. Art. 79. — Joule's Experiment, Second Apparatus.

80. Application of the Kinetic Theory. In the porous plug experiment referred to in Art. 74, it was found that certain gases were slightly cooled as a result of the expansion, and others slightly warmed. The molecules of gas are very much closer to one another in *A* than in *B*, at the beginning of the experiment. If the molecules are *mutually attractive*, the following action takes place: as they emerge from *A*, they are attracted by the remaining particles in that vessel, and their velocity decreases. As they enter *B*, they encounter attractions there, which tend to increase their velocity; but as the second set of attractions is feebler, the total effect is a *loss of velocity* and a *cooling of the gas*. In another gas, in which the molecules *repel* one another, the velocity during passage would be on the whole *augmented*, and the *temperature increased*. A perfect gas would undergo neither increase nor decrease of temperature, for there would be no attractions or repulsions between the molecules.

(1) A critical review of this theory has been presented by Mills: *The Specific Heats of the Elements*, Science, Aug. 24, 1908, p. 221. (2) *The Engineer*, January 13, 1908. (3) Throughout this study, no attention will be paid to the ratio 778 as affecting the numerical value of constants in formulas involving both heat and work

quantities. R may be either 53.36 or $\frac{53.36}{778}$. The student should discern whether heat units or foot-pounds are intended. (4) Zeuner, *Technical Thermodynamics*, Klein tr., I, 121. (5) *Ibid.*, *loc. cit.* (6) Ewing: *The Steam Engine*, 1906. (7) Wormell, *Thermodynamics*.

SYNOPSIS OF CHAPTER IV

Specific thermal capacities; at constant pressure, at constant volume; other capacities. Atomic heat = specific heat \times atomic weight; molecular heat.

The volumetric specific heats of common gases are approximately equal.

Mean specific heat = $\frac{H}{T-t}$; true specific heat = $\frac{dH}{dT}$; real and apparent specific heats.

Regnault's law: "the specific heat is constant for perfect gases."

Difference of the two specific heats: $R = 53.36$; significance of R .

The difference of the volumetric specific heats equals 0.0055 B. t. u. for all gases.

Ratio of the specific heats: $\gamma = 1.402$ for air; relations between k , l , y , R .

Rankine's prediction of the value of k : Mayer's computation of the mechanical equivalent of heat.

Joule's Law: no disgregation work occurs in a perfect gas.

If the temperature does not change, the external work equals the heat absorbed.

If no heat is received, internal energy disappears to an extent equivalent to the external work done.

The condition of intermolecular force determines whether a rise or a fall of temperature occurs in the porous plug experiment.

PROBLEMS

1. The atomic weights of iron, lead, and zinc being respectively 56, 206.4, 65; and the specific heats being, for cast iron, 0.1298; for wrought iron, 0.1138; for lead, 0.0314; and for zinc, 0.0956, — check the theory of Art. 59 and comment on the results.

(*Ans.*, atomic heats are: lead, 6.481; zinc, 6.214; wrought iron, 6.373; cast iron, 7.259.)

2. Find the volumetric specific heats at constant pressure of air, hydrogen, and nitrogen, and compare with Art. 60. ($k = 3.4$ for H and 0.2438 for N .)

(*Ans.*, air 0.01917; hydrogen 0.01901; nitrogen 0.01912.)

3. The heat expended in warming 1 lb. of water from 32° F. to 160° F. being 127.86 B. t. u., find the mean specific heat over this range. (*Ans.*, 0.9989.)

4. The weight of a cubic foot of water being 59.83 lb. at 212° F. and 62.422 lb. at 32° F., find the amount of heat expended in performing external work when one pound of water is heated between these temperatures at atmospheric pressure.

(*Ans.*, 0.00189 B. t. u.)

5. (a) Find the specific heat at constant volume of hydrogen and nitrogen.

(*Ans.*, 2.41; 0.1732.)

(b) Find the value of γ for these two gases. (*Ans.*, 1.4108; 1.4080.)

6. Check the value 0.0055 B. t. u. given in Art. 67 for hydrogen and nitrogen.

(*Ans.*, 0.00554; 0.00554.)

7. Compute the elevation in temperature, in Art. 72, that would, for an expansion of 100 per cent, under the assumed conditions, and with the given values of k and l , give exactly 778 as the value of the mechanical equivalent of heat. What law of gaseous expansion would be invalidated if this elevation of temperature occurred?

(*Ans.*, 489.05° F.)

8. In the experiment of Art. 79, the volume of air in C increased by one cubic foot against normal atmospheric pressure. The weight of water in B was 20 lb. The temperature of the air remained constant throughout the experiment. Ignoring radiation losses, compute the fall of temperature of the water. (*Ans.*, 0.13604° F.)

9. Prove that the specific heat at constant pressure is constant for a perfect gas.

(*Suggestion:* Value of I ? Value of W per degree of temperature change? Value of l from the standpoint of the kinetic theory?)

CHAPTER V

GRAPHICAL REPRESENTATIONS: PRESSURE-VOLUME PATHS OF PERFECT GASES

81. Thermodynamic Coördinates. The condition of a body being fully defined by its pressure, volume, and temperature, its state may be represented on a geometrical diagram in which these properties are used as coördinates. This graphical method of analysis, developed by Clapeyron, is now in universal use. The necessity for *three* coördinates presupposes the use of analytical geometry of three dimensions, and representations may then be shown perspectively as related to one of the eight corners of a cube; but the *projections* on any of the three adjacent cube faces are commonly used; and since any two of three properties fix the third when the characteristic equation is known, a projective representation is sufficient. Since *internal energy* is a cardinal property (Arts. 10, 76), this also may be employed as one of the coördinates of a diagram if desired.

82. Illustration. In Fig. 11 we have one corner of a cube, constituting an origin of coördinates at O . The temperature of a substance is to be represented by the distance upward from O ; its pressure, by the distance to the right; and its volume, by the distance to the left. The lines forming the cube edges are correspondingly marked OT , OP , OV . Consider the condition of the body to be represented by the point A , within the cube. Its *temperature* is then represented by the distance AB , parallel to TO , the point B being in the plane VOP . The distance AD , parallel to PO , from A to the plane TOV , indicates the *pressure*; and by drawing AC parallel to VO , C being the intersection of this line with the plane TOP , we may represent the *volume*. The state of the substance is thus fully shown. Any of the three *projections*, Figs. 12-14, would equally fix its condition, providing the relation between P , V , and T is known. In each of these projections, two of the properties of the substance are shown; in the three projections, each property appears

twice; and the corresponding lines AB , AC , and AD are always equal in length.

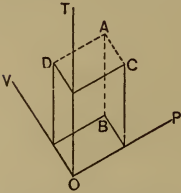

FIG. 11. Art. 82.—
Perspective Dia-
gram.

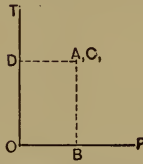

FIG. 12. Art. 82.—
 TP Diagram.

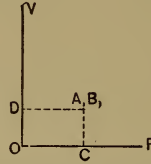

FIG. 13. Art. 82.—
 VP Diagram.

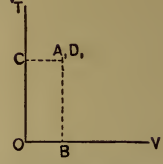

FIG. 14. Art. 82.—
 TV Diagram.

83. Thermal Lines. In Fig. 15, let a substance, originally at A , pass at constant pressure and temperature to the state B ; thence at constant temperature and volume to the state C ; and thence at constant pressure

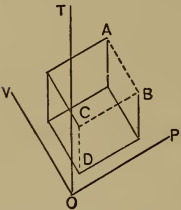

FIG. 15. Art. 83.—
Perspective Ther-
mal Line.

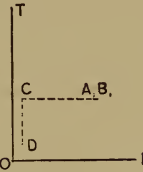

FIG. 16. Art. 83.—
 TP Path.

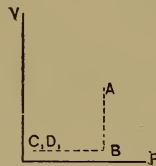

FIG. 17. Art. 83.—
 VP Path.

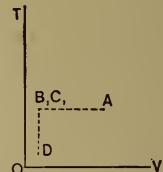

FIG. 18. Art. 83.—
 TV Path.

and volume to D . Its changes are represented by the broken line $ABCD$, which is shown in its various projections in Figs. 16–18. The **thermal line** of the coördinate diagrams, Figs. 11 and 15, is the locus of a series of successive states of the substance. A **path** is the projection of a thermal line on one of the coördinate planes (Figs. 12–14, 16–18). The path of a substance is sometimes called its **process curve**, and its thermal line, a **thermogram**.

The following thermal lines are more or less commonly studied:—

- (a) **Isothermal**, in which the temperature is constant; its plane is perpendicular to the OT axis.
- (b) **Isometric**, in which the volume is constant; having its plane perpendicular to the OV axis.
- (c) **Isopiestic**, in which the pressure is constant; its plane being perpendicular to the OP axis.
- (d) **Isodynamic**, that along which no change of internal energy occurs.

(e) **Adiabatic**, that along which no heat is transferred between the substance and surrounding bodies; the thermal line of an *insulated* body, performing or consuming work.

84. Thermodynamic Surface. Since the equation of a gas includes three variables, its geometrical representation is a surface; and the first three, at least, of the above paths, must be projections of the intersection of a plane with such surface. Figure 19, from Pea-

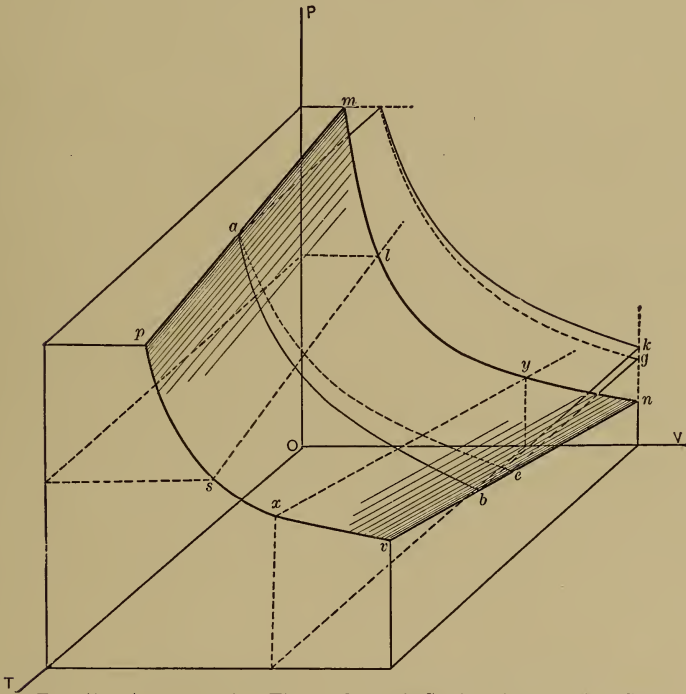

FIG. 19. Arts. 84, 103. — Thermodynamic Surface for a Perfect Gas.

body (1), admirably illustrates the equation of a perfect gas, $PV = RT$. The surface $pmnv$ is the **characteristic surface** for a perfect gas. Every section of this surface parallel to the PV plane is an equilateral hyperbola. Every projection of such section on the PV plane is also an equilateral hyperbola, the coördinates of which express the law of Boyle, $PV = C$. Every section parallel with the TV plane gives straight lines pm, sl , etc., and every section parallel with the TP plane gives straight lines vn, xy , etc. The equations of these

lines are expressions of the two forms of the law of Charles, their appearance being comparable with that in Fig. 5.

85. Path of Water at Constant Pressure. Some such diagram as that of Fig. 20 would represent the behavior of water in its solid, liquid, and vaporous forms when heated at constant pressure.

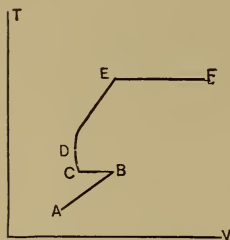

FIG. 20. Art. 85.—Water at Constant Pressure.

The coordinates are temperature and volume. At *A*, the substance is ice, at a temperature below the freezing point. As the ice is heated from *A* to *B*, it undergoes a slight expansion, like other solids. At *B*, the melting point is reached, and as ice contracts in melting, there is a decrease in volume at constant temperature. At *C*, the substance is all water; it contracts until it reaches the temperature of maximum density, 39.1° F., at *D*, then expands until it boils at *E*, when the great

increase in volume of steam over water is shown by the line *EF*. If the steam after formation conformed to Charles' law, the path would continue upward and to the right from *F*, as a straight line.

86. The Diagram of Energy. Of the three coordinate planes, the *PV* is most commonly used. This gives a diagram corresponding with that produced by the steam engine indicator (Art. 484). It is sometimes called **Watt's diagram**. Its importance arises principally from the fact that it represents directly the external work done during the movement of the substance along any path. Consider a vertical cylinder filled with fluid, at the upper end of which is placed a weighted piston. Let the piston be caused to rise by the expansion of the fluid. The force exerted is then equivalent to the weight of the piston, or total pressure on the fluid; the distance moved is the movement of the piston, which is equal to the augmentation in volume of the fluid. Since work equals force multiplied by distance moved, the external work done is equal to the total uniform pressure multiplied by the increase of volume.

87. Theorem. On a *PV* diagram, the external work done along any path is represented by the area included between that path and the perpendiculars from its extremities to the horizontal axis.

Consider first a path of constant pressure, *ab*, Fig. 21. From Art. 86, the external work is equivalent to the pressure multiplied by the increase of volume, or to $ca \times ab = cabd$. *General*

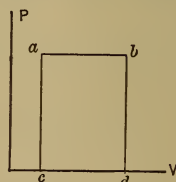

FIG. 21. Art. 87.—External Work at Constant Pressure.

case: let the path be arbitrary, ab , Fig. 22. Divide the area $abdc$ into an infinite number of vertical strips, $amnc$, $mopn$, $oqrp$, etc., each of which may be regarded as a rectangle, such that $ac = mn$, $mn = op$, etc. The external work done along am , mo , oq , etc., is then represented by the areas $amnc$, $mopn$, $oqrp$, etc., and the total external work along the path ab is represented by the sum of these areas, or by $abdc$.

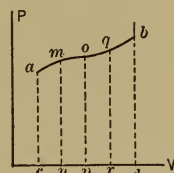

FIG. 22. Arts. 87, 88.
— External Work,
Any Path.

Corollary I. Along a path of constant volume no external work is done.

Corollary II. If the path be reversed, *i.e.* from right to left, as along ba , the volume is diminished, and *negative work* is done; work is *expended* on the substance in *compressing* it, instead of being performed by it.

88. Significance of Path. It is obvious, from Fig. 22, that the amount of external work done depends not only on the initial and final states a and b , but also on the nature of the path between those states. According to Joule's principle (Art. 75) the change of internal energy ($T + I$, Art. 12) between two states of a perfect gas is dependent upon the initial and final temperatures only and is independent of the path. The external work done, however, *depends upon the path*. The *total expenditure of heat*, which includes both effects, can only be known when the path is given. The internal energy of a perfect gas (and, as will presently be shown, Art. 109, of any substance) is a cardinal property; external work and heat transferred are not. They cannot be used as elements of a coördinate diagram.

89. Cycle. A series of paths forming a closed finite figure constitutes a *cycle*. In a cycle, the substance is brought back to its initial conditions of pressure, volume, and temperature.

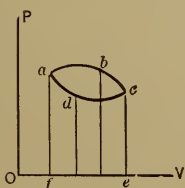

FIG. 23. Art. 89.—
External Work in
Closed Cycle.

Theorem. In a cycle, the net external work done is represented on the PV diagram by the enclosed area.

Let $abcd$, Fig. 23, be any cycle. Along abc , the work done is, from Art. 87, represented by the area $abcef$. Along cda , the *negative* work done is similarly repre-

sented by the area $adcef$. The net positive work done is equivalent to the difference of these two areas, or to $abcd$.

If the volume units are in *cubic feet*, and the pressure units are *pounds per square foot*, then the measured area $abcd$ gives the work in *foot-pounds*. This principle underlies the calculation of the horse power of an engine from its indicator diagram. If the cycle be worked in a *negative* direction, e.g. as $cbad$, Fig. 23, then the net work will be negative; i.e. work will have been *expended upon* the substance, adding heat to it, as in an air compressor.

90. Theorem. In a perfect gas cycle, the expenditure of heat is equivalent to the external work done.

Since the substance has been brought back to its initial temperature, and since the internal energy depends solely upon the temperature, the only heat effect is the external work. In the equation $H = T + I + W$, $T + I = 0$, whence $H = W$, the expenditure of heat being equivalent to its sole effect.

If the work is measured in foot-pounds, the heat expended is calculated by dividing by 778. (See Note 3, page 37.) Conversely, in a *reversed cycle*, the expenditure of external work is equivalent to the *gain* of heat.

91. Isothermal Expansion. The isothermal path is one of much importance in establishing fundamental principles. By definition (Art. 83) it is that path along which the temperature of the fluid is constant. For gases, therefore, from the characteristic equation, if T be made constant, the *isothermal equation* is

$$PV = RT = C.$$

Taking R at 53.36 and T at 491.4° (32° F.),

$$C = 53.36 \times 491.4 = 26,221;$$

whence we plot on Fig. 2 the isothermal curve ab for this temperature; an equilateral hyperbola, asymptotic to the axes of P and V . An infinite number of isothermals might be plotted, depending upon the temperature assigned, as cd , ef , gh , etc. *The equation of the isothermal may be regarded as a special form of the exponential equation $PV^n = C$, in which $n = 1$.*

92. Graphical Method. For rapidly plotting curves of the form $PV = C$, the construction shown in Fig. 24 is useful. Knowing the three corresponding properties of the gas at any given state enables us to fix one point on the curve; thus the volume 12.387 and the pressure 2116.8 give us the point C on the isothermal for 491.4° absolute. Through C draw CM parallel to OV . From O draw lines OD , ON , OM to meet CM . Draw CB parallel to OP . From the points 1, 5, 6, where OD , ON , OM intersect CB , draw lines 1 2, 5 7, 6 8 parallel to OV . From D , N , M , draw lines perpendicular to OV . The points of intersection 2, 7, 8 are points on the required curve. **Proof:** draw EC , $F6$, parallel to OV , and $8A$ parallel to OP . In the similar triangles $O6B$, OMA , we have $6B : MA :: OB : OA$, or $8A : CB :: EC : F8$, whence $8A \times F8 = CB \times EC$, or $P_8V_8 = P_CV_C$.

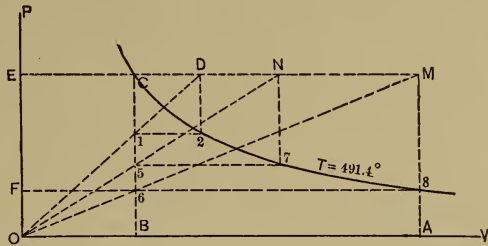

FIG. 24. Art. 92, 95.—Construction of Equilateral Hyperbola.



93. Alternative Method. In Fig. 25 let b be a known point on the curve. Draw ad through b and lay off $DA = ab$. Then A is another point on the curve. Additional points may be found by either of the constructions indicated: *e.g.* by drawing dh and laying off $hf = db$, or by drawing BK and laying off $Kf = BA$. These methods are practically applied in the examination of the expansion lines of steam engine indicator diagrams.

94. Theorem: Along an isothermal path for a perfect gas, the external work done is equivalent to the heat absorbed (Art. 78).

The internal energy is unchanged, as indicated by Joule's law (Art. 75); hence the expenditure of heat is solely for the performance of external work. $H = T + I + W$, but $T = 0$, $T + I = 0$, and $H = W$.

Conversely, we have Mayer's principle, that "the work done in compressing a portion of gas at constant temperature from one volume to another is dynamically equivalent to the heat emitted by the gas during the compression" (2).

95. Work done during Isothermal Expansion. To obtain the external work done under any portion of the isothermal curve, Fig. 24, we must use the integral form,

$$W = \int_v P dV$$

in which v, V are the initial and final volumes. But, from the equation of the curve, $pv = PV$, $P = pv \div V$, and when p and v are given,

$$W = pv \int_v^V \frac{dV}{V} = pv \log_e \frac{V}{v} = Rt \log_e \frac{V}{v} = Rt \log_e \frac{p}{P}.$$

The heat absorbed is equal to this value divided by 778.

96. Perfect Gas Isodynamic (Art. 87). Since in a perfect gas the internal energy is fixed by the temperature alone, the internal energy along an isothermal is constant, and the isodynamic and isothermal paths coincide.

97. Expansion in General. We may for the present limit the consideration of possible paths to those in which increases of volume are accompanied by more or less marked decreases in pressure; the latter ranging, say, from zero to infinity in rate. If the volume increases

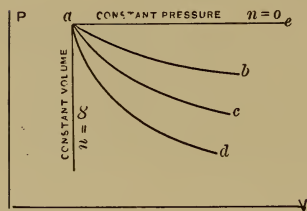

FIG. 26. Art. 97.—Expansive Paths.

increases without any fall in pressure, the path is one of constant pressure; if the volume increases only when the fall of pressure is infinite, the path is one of constant volume. The paths under consideration will usually fall between these two, like ab, ac, ad , etc., Fig. 26. The general law for all of these paths is $PV^n = a$ constant, in which the slope is determined by the value of the exponent n (Art. 91). For $n=0$, the path is one of constant pressure, ae , Fig. 26. For $n=\infty$, the path is one of constant volume.* The “steepness” of the path increases with the value of n . (Note that the exponent n applies to V only, *not* to the whole expression.)

98. Work done by Expansion. For this general case, the external work area, adopting the notation of Art. 95, is,

$$W = \int_v^V P dV;$$

But since $pv^n = PV^n$, $P = pv^n \div V^n$; whence, when p and v are given,

$$W = pv^n \int_v^V (dV \div V^n) = \frac{pv^n}{1-n} (V^{1-n} - v^{1-n}) = \frac{pv - PV}{n-1} = \frac{R(t - T)}{n-1}.$$

* $V^n = 1$, where $n=0$. If $n=\infty$, we may write $\frac{1}{P^\infty} V = \frac{1}{p^\infty} v$, or $V=v$.

When $V = \infty$, $P = 0$, and the work is indeterminate by this expression; but we may write $W = \frac{pv}{n-1} \left(1 - \frac{PV}{pv} \right) = \frac{pv}{n-1} \left[1 - \left(\frac{v}{V} \right)^{n-1} \right]$, in which, for $V = \infty$, $W = pv \div (n-1)$, a finite quantity. The work under an exponential curve (when $n > 1$) is thus finite and commensurable, no matter how far the expansion be continued.

99. Relations of Properties. For a perfect gas, in which $\frac{PV}{T} = \frac{pv}{t}$, we have

$$PVt = pvT.$$

If expansion proceeds according to the law $PV^n = pv^n$, we obtain, dividing the first of these equations by the second,

$$\frac{V}{V^n} t = \frac{v}{v^n} T, \text{ whence } \frac{t}{T} = \left(\frac{v}{V} \right)^{1-n}.$$

This result permits of the computation of the change in temperature following a given expansion. We may similarly derive a relation between temperature and pressure. Since

$pv^n = PV^n$, $v(p)^{\frac{1}{n}} = V(P)^{\frac{1}{n}}$. Dividing the expression $pvT = PVt$ by this, we have

$$T(p)^{\frac{n-1}{n}} = t(P)^{\frac{n-1}{n}}, \text{ whence } \frac{T}{t} = \left(\frac{P}{p} \right)^{\frac{n-1}{n}}.$$

By interpretation of these formulas of relation, we observe that for values of n exceeding unity, during expansion (*i.e.* increase of volume), the pressure and temperature decrease, while external work is done. The gain or loss of heat we cannot yet determine. On the other hand, during compression, the volume decreases, the pressure and temperature increase, and work is spent upon the gas. In the work expression of Art. 98, if p, v, t are always understood to denote the initial conditions, and P, V, T , the final conditions, then the work quantity for a *compression* is *negative*.

100. Adiabatic Process. This term (Art. 83) is applied to any process conducted without the reception or rejection of heat from or to surrounding bodies by the substance under consideration. It is by far the most important mode of expansion which we shall have to consider. The substance expands without giving heat to, or taking heat from, other bodies. *It may lose heat, by doing work*; or, in compression, *work may be expended* on the substance so as to cause it to *gain heat*: but there is **no transfer** of heat between it and surrounding bodies. If air could be worked in a perfectly non-conducting cylinder, we should have a practical instance of adiabatic expansion. In practice we sometimes approach the adiabatic path closely, by causing expansion to take place with great rapidity, so that there is no time

for the transfer of heat. The expansions and compressions of the air which occur in sound waves are adiabatic, on account of their rapidity (Art. 105). In the fundamental equation $H = T + I + W$, the adiabatic process makes $H = 0$, whence $W = -(T + I)$; or, *the external work done is equivalent to the loss of internal energy, at the expense of which energy the work is performed.*

101. Adiabatic Equation. Let unit quantity of gas expand adiabatically to an infinitesimal extent, increasing its volume by dv , and decreasing its pressure and temperature by dp and dt . As has just been shown, $W = -(T + I)$, the expression in the parenthesis denoting the change in internal energy during expansion. The heat necessary to produce this change would be ldt , l being the specific heat at constant volume. The external work done is $W = pdv$; consequently, $pdv = -ldt$. From the equation of the gas, $pv = Rt$, $t = \frac{pv}{R}$, whence, $dt = \frac{1}{R}(pdv + vdp)$. Using this value for dt ,

$$pdv = -\frac{l}{R}(pdv + vdp).$$

But R is equal to the difference of the specific heats, or to $k - l$; so that

$$pdv = -\frac{l}{k - l}(pdv + vdp),$$

$$\frac{(k - l)pdv}{l} = -pdv - vdp,$$

$$ypdv - pdv = -pdv - vdp,$$

$$\frac{ydv}{v} = -\frac{dp}{p}, \text{ giving by integration,}$$

$$y \log_e v + \log_e p = \text{constant,}$$

$$\text{or } pv^y = \text{constant,}$$

y being the ratio of the specific heats at constant pressure and constant volume (Art. 69.)

102. Second Derivation. A simpler, though less satisfactory, mode of derivation of the adiabatic equation is adopted by some writers. Assuming that the adiabatic is a special case of expansion according to the law $pv^n = PV^n$, the external work done, according to Art. 98, is

$$\frac{R(t - T)}{n - 1}.$$

During a change of temperature from t to T , the change in internal energy is $l(t - T)$, or from Art. 70, since $l = R \div (y - 1)$, it is

$$\frac{R(t - T)}{y - 1}.$$

But in adiabatic expansion, the external work done is equivalent to the change in internal energy; consequently

$$\frac{R(t - T)}{n - 1} = \frac{R(t - T)}{y - 1},$$

$n = y$, and the adiabatic equation is $p v^y = P V^y$. For air, the adiabatic is then represented by the expression $p(v)^{1.402} = \text{a constant}$.

103. Graphical Presentation. Since along an adiabatic the external work is done at the expense of the internal energy, the temperature must fall during expansion. In the diagram of Fig. 19, this is shown by comparing the line ab , an isothermal, with ae , an adiabatic. The relation of p to v , in adiabatic expansion, is such as to cause the temperature to fall. The projections of these two paths on the $p v$ plane show that as expansion proceeds from a , the pressure falls more rapidly along the adiabatic than along the isothermal, a result which might have been anticipated from comparison of the equations of the two paths. If an isothermal and an adiabatic be drawn through the same point, the latter will be the "steeper" of the two curves. Any number of adiabatics may be constructed on the $p v$ diagram, depending upon the value assigned to the constant ($p v^y$); but since this value is determined, for any particular perfect gas, by contemporaneous values of p and v , only one adiabatic can be drawn for a given gas through a given point.

104. Relations of Properties. By the methods of Art. 98 and Art. 99, we find, for adiabatic changes,

$$p v^y = P V^y, \frac{t}{T} = \left(\frac{v}{V}\right)^{1-y}, \frac{T}{t} = \left(\frac{P}{p}\right)^{\frac{y-1}{y}}, \frac{P}{p} = \left(\frac{v}{V}\right)^y, W = \frac{p v - P V}{y - 1}.$$

During expansion, the pressure and temperature decrease, external work is done at the expense of the internal energy, and there is no reception or rejection of heat.

105. Direct Calculation of the Value of y . The velocity of a wave in an astic medium is, according to a fundamental proposition in dynamics, equal to the square root of the coefficient of elasticity divided by the mass density:* that is,

$$V = \sqrt{\frac{g e}{w}}.$$

* See, for example, Appendix A to Vol. III of Nichols and Franklin's *Elements of Physics*.

V being in feet per second and w in lbs. per cubic foot. When a volume of gas of cross-section $=n$ and length l is subjected to the specific pressure increment dp , producing the extension (negative compression) $-dl$,

$$e = -\frac{dp}{dl \div l}$$

The volume of this gas is $ln = v$: so that $\frac{dl}{l} = \frac{dv}{v}$ and $e = -\frac{vdp}{dv}$. The pulsations which constitute a sound wave are very rapid, hence adiabatic, so that $pv^\gamma = \text{constant}$, and

$$ypv^{\gamma-1}dv = -v^\gamma dp$$

$$-\frac{ypv^{\gamma-1}}{v^\gamma} = \frac{dp}{dv} = -\frac{yp}{v}$$

$$-\frac{vdp}{dv} = e = yp$$

$$V = \sqrt{\frac{gyP}{w}}$$

$$y = \frac{V^2 w}{gP}$$

For 32° F. and $p = 14.697 \times 144$, $w = 0.081$. Taking g at 32.19 and V at the experimental value of 1089,

$$y = \frac{1089 \times 1089 \times 0.081}{32.19 \times 14.697 \times 144} = 1.411. \quad (3)$$

105 a. Velocity with Extreme Pressure Changes. The preceding computation applies to the propagation of a pressure wave of very small intensity from a localized starting point. Where the pressure rises considerably — say from p to P , the volume meanwhile decreasing from v to V_0 , then

$$V_0 = \left(\frac{p}{P}\right)^{\frac{1}{\gamma}} v,$$

$$v - V_0 = v \left\{ 1 - \left(\frac{p}{P}\right)^{\frac{1}{\gamma}} \right\}.$$

Now V (velocity) $= \sqrt{\frac{ge}{w}}$ and $e = -\frac{(P-p)v}{V_0 - v}$ for finite changes. If v is the volume of W lb. of gas (*not the specific volume*), $pv = RtW$, $W = \frac{pv}{Rt}$, and we have for the velocity,

$$V = \sqrt{\frac{gv(P-p)Rt}{(v - V_0)pv}} = \sqrt{\frac{gRt(P-p)}{p \left\{ 1 - \left(\frac{p}{P}\right)^{\frac{1}{\gamma}} \right\}}}$$

For $t = 530$, $p = 100$, $P = 400$, this becomes

$$V = \sqrt{\frac{32.2 \times 53.36 \times 530 \times 300 \times 144}{100 \times 144 \left\{ 1 - \left(\frac{100}{400} \right)^{0.713} \right\}}} = \sqrt{\frac{39,200,000,000}{9060}} = 2078 \text{ ft. per second.}$$

This would be the velocity of the explosion in the cylinder of an internal combustion engine if the pressure were generated at all points simultaneously. As a matter of fact, the combustion is local and the velocity and pressure rise are much less than those thus computed (Art. 319).

106. Representation of Heat Absorbed. Theorem: The heat absorbed on any path is represented on the PV diagram by the area enclosed between that path and the two adiabatics through its extremities, indefinitely prolonged to the right.

Let the path be ab , Fig. 27. Draw the adiabatics an , bN . These may be conceived to meet at an infinite distance to the right, forming with the path the closed cycle $abNn$. In such closed cycle, the total expenditure of heat is, from Art. 90, represented by the enclosed area; but since no heat is absorbed or emitted along the adiabatics, all of the heat changes in the cycle must have occurred along the path ab , and this change of heat is represented by the area $abNn$. If the path be taken in the reverse direction, *i.e.* from b to a , the area $abNn$ measures the *heat emitted*.

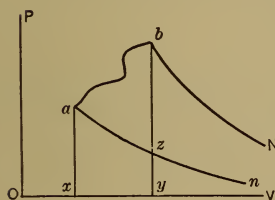

FIG. 27. Arts. 106, 109.—Representation of Heat Absorbed.

107. Representations of Thermal Capacities. Let ab , cd , Fig. 28, be two isothermals, differing by one degree. Then $efnN$ represents the *specific heat at constant volume*, $egmN$ the *specific heat at constant pressure*, eN , fn , and gm being adiabatics. The latter is apparently the greater, as it should be. Similarly, if ab denotes unit increase of volume, the area $abMN$ represents the *latent heat of expansion*. The other thermal capacities mentioned in Art. 58 may be similarly represented.

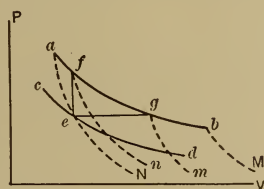

FIG. 28. Art. 107.—Thermal Capacities.

108. Isodiabatics. An infinite number of expansion paths is possible through the same point, if the n values are different. An infinite number of curves may be drawn, having the same n value, if they do not at any of their points intersect. Through a given point and with a given value of n , only one curve can be drawn. When two or more curves appear on the same diagram, each having the same exponent (n

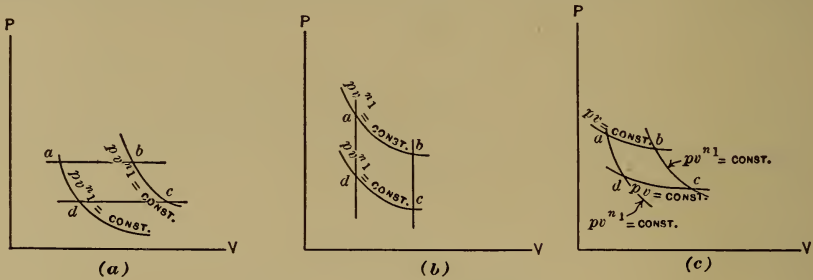

FIG. 29. Art. 108.—Isodiabatics.

value), such curves are called **isodiabatics**. In most problems relating to heat motors, curves appear in isodiabatic pairs. Much labor may be saved in computation by carefully noting the following relations:

1. In Fig. 29 (a), let the isodiabatics $pv^{n_1} = \text{const.}$ be intersected by lines of constant pressure at a, b, c and d . Then

$$\left. \begin{aligned} \left(\frac{P_a}{P_d}\right)^{\frac{n_1-1}{n_1}} &= \frac{T_a}{T_d} \\ \left(\frac{P_b}{P_c}\right)^{\frac{n_1-1}{n_1}} &= \frac{T_b}{T_c} \end{aligned} \right\} \text{(Art. 99).}$$

$$P_a = P_b, \quad P_a = P_c, \quad n_1 = n_1;$$

$$\therefore \frac{T_a}{T_d} = \frac{T_b}{T_c} \quad \text{and} \quad \frac{T_a}{T_b} = \frac{T_d}{T_c} = \frac{V_a}{V_b} = \frac{V_d}{V_c} \text{ (Art. 41).}$$

2. In Fig. 29 (b), let the same isodiabatics be intersected by lines of constant volume, determining points a, b, c and d . Then

$$\left. \begin{aligned} \left(\frac{V_a}{V_b}\right)^{1-n_1} &= \frac{T_a}{T_b} \\ \left(\frac{V_d}{V_c}\right)^{1-n_1} &= \frac{T_d}{T_c} \end{aligned} \right\} \text{(Art. 99).}$$

$$V_a = V_d, \quad V_b = V_c, \quad n_1 = n_1;$$

$$\therefore \frac{T_a}{T_b} = \frac{T_d}{T_c} \quad \text{and} \quad \frac{T_a}{T_d} = \frac{T_b}{T_c} = \frac{P_a}{P_d} = \frac{P_b}{P_c} \text{ (Art. 41).}$$

3. In Fig. 29 (c), the same isodiabatics are intersected by *isothermals* at *a*, *b*, *c* and *d*. Now

$$\left. \begin{aligned} \left(\frac{P_a}{P_d}\right)^{\frac{n_1-1}{n_1}} &= \frac{T_a}{T_d} \\ \left(\frac{P_b}{P_c}\right)^{\frac{n_1-1}{n_1}} &= \frac{T_b}{T_c} \end{aligned} \right\} \text{(Art. 99).}$$

$$T_a = T_b, \quad T_d = T_c, \quad n_1 = n_1;$$

$$\therefore \frac{P_a}{P_d} = \frac{P_b}{P_c} \quad \text{and} \quad \frac{P_a}{P_b} = \frac{P_d}{P_c}. \quad \text{(I)}$$

In this case, it is easy to show also, that

$$\frac{V_a}{V_b} = \frac{V_d}{V_c} \quad \text{and} \quad \frac{V_a}{V_d} = \frac{V_b}{V_c}; \quad \text{(II)}$$

but in this case (I) is not equal to (II): *the volume ratio is not equal to the pressure ratio*. Note also that in each of the three cases the equality of ratios exists between properties **other than that made constant** along the intersecting lines; thus, in (a), the pressure is constant, and the volume and temperature *ratio* is constant.

109. Joule's Law. From the theorem of Art. 106, Rankine has illustrated in a very simple manner the principle of Joule, that *the change of internal energy along any path of any substance depends upon the initial and final states alone, and not upon the nature of the path*. In Fig. 27, draw the vertical lines *ax*, *by*. The total heat absorbed along *ab* = *nabN*, the external work done = *xaby*. The difference = *nabN* - *xaby* = *nzbN* - *xazy*, is the change in internal energy; $H = T + I + W$, whence $H - W = (T + I)$; and the extent of these areas is *unaffected by any change in the path ab, so long as the points a and b remain fixed*.

110. Value of y . A method of computing the value of y for air has been given in Art. 105. The apparatus shown in Fig. 30 has been used by several observers to obtain direct values for various gases. The vessel was filled with gas at P, V , and T , T being the temperature of the atmosphere, and P a pressure somewhat in excess of that of the atmosphere. By opening the stopcock, a sudden expansion took place, the pressure falling to that of the atmosphere, and the temperature falling to a point considerably below that of the atmosphere. Let the state of the gas after this adiabatic expansion be p, v, t . Then, since

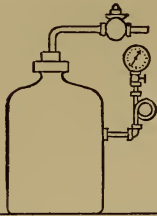

FIG. 30. Art. 110.—Desormes' Apparatus.

$$PV^y = pv^{y*}$$

$$y = \frac{\log p - \log P}{\log V - \log v}$$

After this operation, the stopcock is closed, and the gas remaining in the vessel is allowed to return to its initial condition of temperature, T . During this operation, the volume remains constant; so that the final state is p_2, v, T ; whence $p_2v = PV$, or $\log V - \log v = \log p_2 - \log P$. Substituting this value of $\log V - \log v$ in the expression for y , we have

$$y = \frac{\log p - \log P}{\log p_2 - \log P},$$

so that the value of y may be computed from the pressure changes alone. Clement and Desormes obtained in this manner for air, $y = 1.3524$; Gay-Lussac and Wilter found $y = 1.3745$. The experiments of Hirn, Weisbach, Masson, Cazin, and Kohlrausch were conducted in the same manner. The method is not sufficiently exact.

111. Expansions in General. In adiabatic expansion, the external work done and the change in internal energy are equally represented by the expression $\frac{pv - PV}{y - 1}$, derived as in Art. 98. For expansion from p, v to infinite volume, this becomes $\frac{pv}{y - 1}$. The external work done during any expansion according to the law $pv^n = PV^n$ from pv to PV , is $W = \frac{pv - PV}{n - 1}$.

The stock of internal energy at p, v , is $\frac{pv}{y - 1} = ut$; at P, V , it is $\frac{PV}{y - 1} = lT$. The total heat expended during expansion is equal to the algebraic sum of the external work done and the internal energy gained. Then,

* The final condition being that of the atmosphere, all of the gas, both within and without the vessel, is at the condition p, v, t . The change in quantity (weight) of gas in the vessel during the expansion does not, therefore, invalidate the equation.

$$\begin{aligned}
 H &= (T + I) + W = \frac{PV}{y-1} - \frac{pv}{y-1} + \frac{pv - PV}{n-1} = (pv - PV) \left(\frac{1}{n-1} - \frac{1}{y-1} \right) \\
 &= R(t - T) \left(\frac{1}{n-1} - \frac{1}{y-1} \right) = (k - l)(t - T) \left(\frac{1}{n-1} - \frac{1}{y-1} \right) \\
 &= l(y-1)(t - T) \left(\frac{1}{n-1} - \frac{1}{y-1} \right) = l(t - T) \left(\frac{y-1}{n-1} - 1 \right) \\
 &= l(t - T) \left(\frac{y-n}{n-1} \right), \text{ in which } t \text{ is the initial, and } T \text{ the final temperature.}
 \end{aligned}$$

This gives a measure of the net heat absorbed or emitted during any expansion or compression according to the law $pv^n = \text{constant}$. When n exceeds y , the sign of H is minus; heat is emitted; when n is less than y but greater than 1.0, heat is absorbed: the temperature falling in both cases. When $n = y$, the path is adiabatic, and heat is neither absorbed nor emitted.

112. Specific Heat. Since for any change of temperature involving a heat absorption H , the mean specific heat is

$$s = \frac{H}{T - t},$$

we derive from the last equation of Art. 111 the expression,

$$s = l \frac{n - y}{n - 1},$$

giving the specific heat along any path $pv^n = PV^n$. Since the values of n are the same for *isothermals*, the specific heats along such paths are equal (Art. 108).

113. Ratio of Internal Energy Change to External Work. For any given value of n , this ratio has the constant value

$$\frac{n - 1}{y - 1}.$$

114. Polytropic Paths. A name is needed for that class of paths following the general law $pv^n = PV^n$, a constant. Since for any gas y and l are constant, and since for any particular one of these paths n is constant, the final formula of Art. 111 reduces to

$$H = (f)(t - T).$$

In other words, *the rate of heat absorption or emission is directly proportional to the temperature change; the specific heat is constant. Such paths are called **polytropic**.* A large proportion of the paths exemplified in engineering problems may be treated as polytropics. The polytropic curve is the characteristic expansive path for constant weight of fluid.

115. Relations of n and s . We have discussed such paths in which the value of n ranges from 1.0 to infinity. Figure 31 will make the conception more general. Let a represent the initial condition of the gas. If

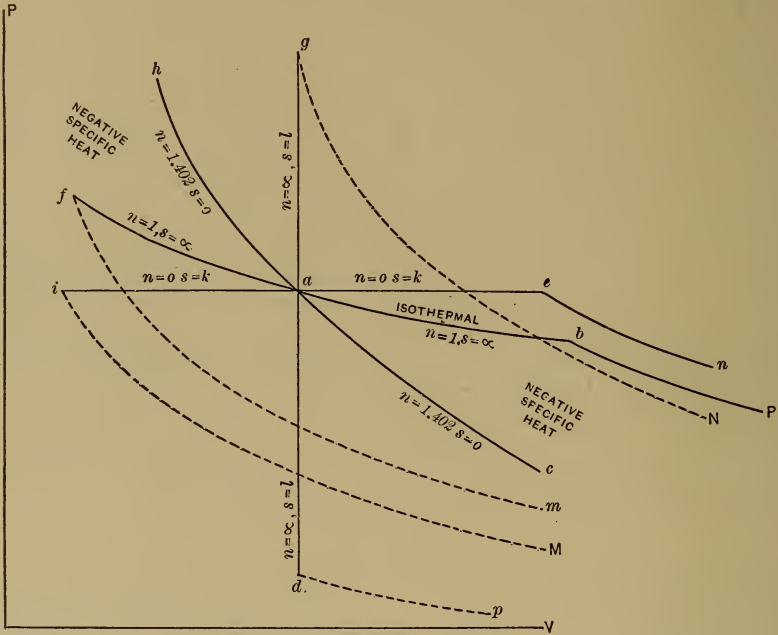

FIG. 31. Art. 115.—Polytropic Paths.

it expands along the isothermal ab , $n = 1$, and s , the specific heat, is infinite; no addition of heat whatever can change the temperature. If it expands at constant pressure, along ae , $n = 0$, and the specific heat is finite and equal to $ly = k$. If the path is ag , at constant volume, n is infinite and the specific heat is positive, finite, and equal to l . Along the isothermal af (compression), the value of n is 1, and s is again infinite. Along the adiabatic ah , $n = 1.402$ and $s = 0$. Along ai , $n = 0$ and $s = k$. Along ad , n is infinite and $s = l$. Most of these relations are directly derived from Art. 112, or may in some cases be even more readily apprehended by drawing the adiabatics, en , gN , fm , iM , dp , bP , and noting the signs of the areas representing heats absorbed or emitted with changes in temperature. For any path lying between ah and af or between ac and ab , the specific heat is negative, *i.e.* the addition of heat cannot keep the temperature from falling: nor its abstraction from rising.

116. Relations of Curves: Graphical Representation of n . Any number of curves may be drawn, following the law $pv^n = C$, as the value of C is changed.

In Fig. 32, let ab, cd, ef be curves thus drawn. Their general equation is $pv^n = C$,

whence $\frac{npdv}{v} + dp = 0$ or

$$-\frac{dp}{dv} = n \frac{p}{v}.$$

If MTV is the angle made by the tangent to one of the curves with the axis OV , and MOV the angle formed by the radius vector RM with the axis OV , then, since $dp \div dv$ is the tangent of MTV , and $p \div v$ is the tangent of MOV ,

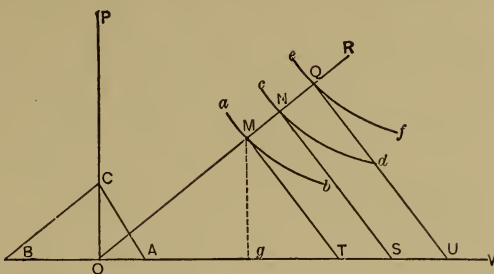

FIG. 32. Art. 116.—Determination of Exponent.

$$-\tan MTV = n \tan MOV.$$

If the radius vector be produced as $RMNQ$, the relations of the angles made between the OV axis and the successive tangents MT, NS, QU , are to the angle MOV as just given; hence the various tangents are parallel (4).

Since $\tan MTV = Mg \div gT$ and $\tan MOV = Mg \div Og$, the preceding equation gives

$$-\frac{Mg}{gT} = n \frac{Mg}{Og},$$

whence $n = Og \div gT$. (The algebraic signs of Og and gT , measured from g , are different.) In order to determine the value of n from a given curve, we need therefore only draw a tangent MT and a radius vector MO , whence by dropping the perpendicular Mg the relation $Og \div gT$ is established. If we lay off from O the distance OA as a unit of length, drawing AC parallel to the tangent, and CB through C , parallel to the

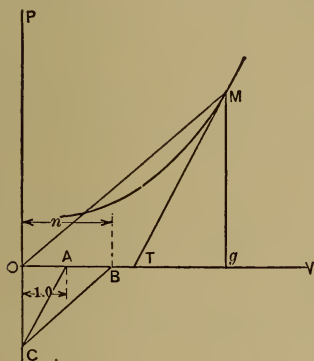

FIG. 33. Art. 116.—Negative Exponent.

radius vector, then by similar triangles $Og : gT :: OB : OA$ and $Og \div gT = OB = n$. Figure 33 illustrates the generality of this method by showing its application to a curve in which the value of n is negative.

117. Plotting of Curves: Brauer's Method. The following is a simple method for the plotting of exponential curves, including the adiabatic, which is ordinarily a tedious process. Let the point M , Fig. 34, be given as one point on the required curve. Draw a line OA making an angle VOA with the axis OV , and a line OB making an angle POB with the axis

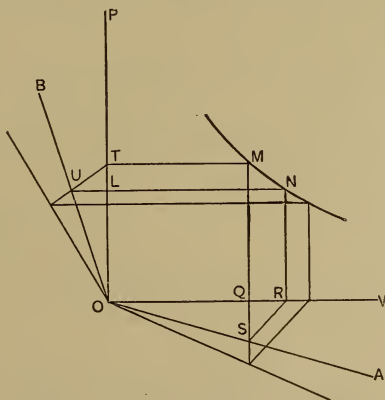

FIG. 34. Art. 117.—Brauer's Method.

OP. Draw the vertical line *MS* and the horizontal line *MT*. Also draw the line *TU* making an angle of 45° with *OP*, and the line *SR* making an angle of 45° with *MS*. Draw the vertical line *RN* through *R*, and the horizontal line *UN* through *U*. The coördinates of the point of intersection, *N*, of these lines, are *OR* and *RN*. Let the coördinates of *M*, *TM* ($= OQ$), and *MQ* be designated by v, p ; and those of *N*, *OR*, and *RN* ($= OL$), by V, P . Then $\tan \angle VOA = QS \div OQ = QR \div TM = (V - v) \div v$; and $\tan \angle POB = UL \div OL = TL \div NR = (p - P) \div P$; whence $V = v(\tan \angle VOA + 1)$ and $p = P(\tan \angle POB + 1)$. If the law of the curve through *M* and *N* is to be $pv^n = PV^n$, we obtain

$$P(\tan \angle POB + 1)v^n = P\{v(\tan \angle VOA + 1)\}^n,$$

whence $(\tan \angle POB + 1) = (\tan \angle VOA + 1)^n$. If now, in the first place, we make the angles *POB*, *VOA* such as to fulfill this condition, then the point *N* and others similarly determined will be points on a curve following the law $pv^n = PV^n$.

118. Tabular Method. The equation $pv^n = PV^n$ may be written $p = P\left(\frac{V}{v}\right)^n$ or $\log p - \log P = n \log(V \div v)$. If we express *P* as a definite initial pressure for all PV^n curves, then for a specific value of *n* and for definite ratios $V \div v$ we may tabulate successive values of $\log p$ and of *p*. Such tables for various values of *n* are commonly used. In employing them, the final pressure is found in terms of the initial pressure for various ratios of final to initial volume.

119. Representation of Internal Energy. In Fig. 35, let *An* represent an adiabetic. During expansion from *A* to *a*, the external work done is *Aabc*, which, from the law of the adiabetic, is equal to the expenditure of internal energy. If expansion is continued indefinitely, the adiabetic *An* gradually approaches the axis *OV*, the area below it continually representing expenditure of internal energy, until with infinite expansion *An* and *OV* coincide. The internal energy is then exhausted. The total internal energy of a substance may therefore be represented by the area between the adiabetic through its state, indefinitely prolonged to the right, and the horizontal axis. Representing this quantity by *E*, then from Art. 111,

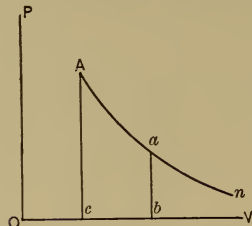

FIG. 35. Art. 119.—Representation of Internal Energy.

$$E = \int_v^{\infty} p dv = \frac{pv}{y-1}$$

where *v* is the initial volume, *p* the initial pressure, and *y* the adiabetic exponent. This is a finite and commensurable quantity.

120. Representation by Isodynamic Lines. A defect of the preceding representation is that the areas cannot be included on a finite diagram.

In Fig. 36, consider the path AB . Let BC be an adiabetic and AC anisodynamic. It is required to find the change of internal energy between A and B . The external work done during adiabetic expansion from B to C is equal to $BCcb$; and this is equal to the change of internal energy between B and C . But the internal energy is the same at C as at A , because AC is an isodynamic. Consequently, the change of internal energy between A and B is represented by the area $BCcb$; or, generally, by the area included between the adiabetic through the final state, extended to its intersection with the isodynamic through the initial state, and the horizontal axis.

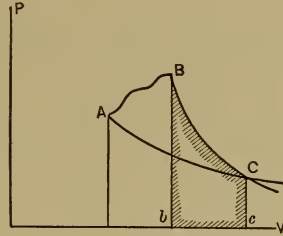

FIG. 36. Arts. 120, 121.—Internal Energy, Second Diagram.

121. Source of External Work.

If in Fig. 36 the path is such as to increase the temperature of the substance, or even to keep its temperature from decreasing as much as it would along an adiabetic, then heat must be absorbed. Thus, comparing the paths ad and ac , Fig. 37, aN and cm being adiatics, the external work done along ad is $adef$, no heat is absorbed, and the internal energy decreases by $adef$. Along ac , the external work done is $acef$, of which $adef$ was done at the expense of the internal energy, and acd by reason of the heat absorbed. The total heat absorbed was $Nacm$, of which acd was expended in doing external work, while $Ndcn$ went to increase the stock of internal energy.

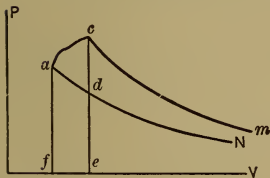

FIG. 37. Art. 121.—External Work and Internal Energy.

122. Application to Isothermal Expansion.

If the path is isothermal, Fig. 38, line AB , then if BN , An are adiatics, we have,

$$W + X = \text{external work done,}$$

$$X + Y = \text{heat absorbed} = W + X,$$

$$W + Z = \text{internal energy at } A,$$

$$Y + Z = \text{internal energy at } B,$$

W = work done at the expense of the internal energy present at A ,

X = work done by reason of the absorption of heat along AB ,

Z = residual internal energy of that originally present at A ,

Y = additional internal energy imparted by the heat absorbed;

and since in a perfect gas isothermals are isodynamics, we note that

$$W + Z = Y + Z \text{ and } W = Y \text{ (5).}$$

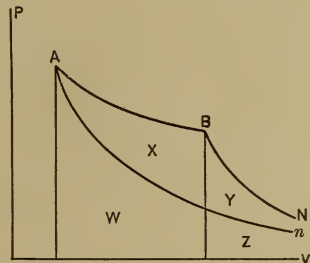

FIG. 38. Art. 122.—Heat and Work in Isothermal Expansion.

123. Finite Area representing Heat Expenditure. In Fig. 39, let ab be any path, bn and aN adiabatics, and ac an isodynamic. The external work done along

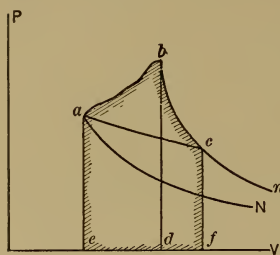

FIG. 39. Art. 123.—Representation of Heat Absorbed.

work done is $agde$. The change of internal energy, from Art. 120, is $bgdf$, if ab is an isodynamic; and this being a negative area, we note that internal energy has been **expended**, although heat has been absorbed. Consequently, the temperature has fallen. It seems absurd to conceive of a substance as receiving heat while falling in temperature. The explanation is that it is cooling, by doing external work, faster than the supply of heat can warm it. Thus, $H = T + I + W$; but $H < W$; consequently, $(T + I)$ is negative.

ab is $abde$; while the increase of internal energy is $bcfl$. The **total heat absorbed** is then represented by the combined areas $abcfe$. If the path ab is isothermal, this construction leads to the known result that there is no gain of internal energy, and that *the total heat absorbed equals the external work*. If the path be one of those described in Art. 115 as of negative specific heat, we may represent it as ag ,

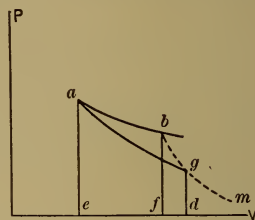
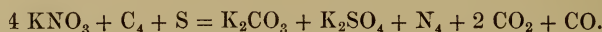

FIG. 40. Art. 123.—Negative Specific Heat.

123 a. Ordnance. Some such equation as that given in Art. 105 *a* may apply to the explosion of the charge in a gun. Ordinary gunpowder, unlike various detonating compounds now used, is scarcely a true explosive. It is merely a rapidly burning mixture. A probable expression for the reaction with a common type of powder is



It will be noted that a large proportion of the products of combustion are *solids*; probably, in usual practice, from 55 to 70 per cent. As first formed, these may be in the liquid or gaseous state, in which case they contribute large quantities of heat to the expanding and cooling charge as they liquefy and solidify.

When the charge is first fired, if the projectile stands still, the temperature and pressure will rise proportionately, and the rise of the former will be the quotient of the heat evolved by the mean specific heat of the products of combustion. Fortunately for designers, the projectile moves at an early stage of the combustion, so that the rise of pressure and temperature is not instantaneous, and the shock is more or less gradual. After the attainment of maximum pressure, the gases expand, driving the projectile forward. Work is done in accelerating the latter, but the process is not adiabatic because of the contribution of heat by the ultimately solid combustion products. The temperature does fall, however, so that the expansion is one between the isothermal and the adiabatic.

The ideal in design is to obtain the highest possible muzzle velocity, but this should be accomplished without excessive maximum pressures. The more nearly

the condition of constant pressure can be approximated during the travel of the projectile from breech to muzzle, the better. Both velocities and pressures during this traverse have been studied experimentally; the former by the chronoscope, the latter by the crusher gage.

The suddenness of pressure increase may be retarded by increasing the density of the powder, and is considerably affected by its fineness and by the shape and uniformity of the grains.

Suppose 1 + s lb. of charge to contain s lb. of permanently solid matter of specific heat = c , and that the specific heat of the gaseous products of combustion, during their combustion, is l . Let the initial temperature be 0° F. Then the temperature attained by combustion is

$$T = \frac{H}{l + cs},$$

where H is the heat evolved in combustion. During any part of the subsequent expansion,

$$H = T + I + W = E + W,$$

$$dH = ldt + pdv.$$

The only heat contributed is that by the solid residue, and is equal to

$$dH = -scdt = ldt + pdv,$$

so that

$$-(sc + l) dt = pdv = Rl \frac{dv}{v},$$

$$-(sc + l) \frac{dt}{l} = R \frac{dv}{v},$$

and between the limits T and t ,

$$\log_e \left(\frac{t}{T} \right)^{sc+l} = \log_e \left(\frac{V}{v} \right)^{k-l},$$

$$t = T \left(\frac{V}{v} \right)^{\frac{k-l}{sc+l}},$$

where V is the initial and v the final volume of the charge. Now since $p \frac{v}{t} = \frac{PV}{T}$,

$\frac{p}{P} = \frac{Vt}{vT} = \left(\frac{V}{v} \right)^{\frac{k+sc}{l+sc}}$. The external work done during expansion is

$$W = \int pdv = - \int ldt - \int scdt = (sc + l) (T - t)$$

$$= (sc + l) T \left\{ 1 - \left(\frac{V}{v} \right)^{\frac{k-l}{sc+l}} \right\}.$$

If we wish to include the effect due to the fact that a portion, say r , of the original volume of charge forms non-gaseous products, we may write for V , $V(1 - r)$, and for v , $v - rV$, and the complete equation becomes

$$W = (sc + l) T \left\{ 1 - \left(\frac{V(1 - r)}{v - rV} \right)^{\frac{k-l}{sc+l}} \right\}.$$

Suppose $T = 4000^\circ$ F., $s = 0.6$, $c = 0.1$, $l = 0.18$, $k = 0.25$, $V = 0.02$, $r = 0.6$, $v = 0.20$; then

$$W = 0.24 \times 4000 \times 778 \left\{ 1 - \left(\frac{0.02 \times 0.4}{0.20 - 0.012} \right)^{\frac{0.07}{0.24}} \right\} = 491,000 \text{ ft.-lb.}$$

If w be the weight of projectile, V_0 the velocity imparted thereto, and f the "factor of effect" to care for practical deductions from the computed value of W , then

$$fW = \frac{1}{2} m V_0^2 = \frac{w}{2g} V_0^2 \quad \text{and}$$

$$V_0 = \sqrt{\frac{2gWf}{w}}$$

which for our conditions, with $w = 5$, $f = 0.90$, gives

$$V_0 = \sqrt{\frac{64.4 \times 491,000 \times 0.90}{5}} = 2390 \text{ ft. per second.}$$

The maximum work possible would be obtained in a gun of ample length, the products of combustion expanding down to their initial temperature, and would be, for our conditions,

$$W = 778 H = 778 T(l + cs) = 778 \times 4000 \times 0.24 = 814,080 \text{ ft.-lb.}$$

The equation of the expansion curve is $pv^n = \text{const.}$, where n has the value $\frac{k + sc}{l + sc}$; or, for our conditions $\frac{0.31}{0.24} = 1.3$, nearly.

Viewing the matter in another way: the heat contributed by the solid residues is that absorbed by the gases; or

$$sc = -s_1,$$

where s_1 is the specific heat of the gases during expansion.

$$\text{Then} \quad s_1 = l \frac{n - y}{n - 1} \quad \text{and} \quad n = \frac{k + sc}{l + sc}, \quad \text{as before.}$$

The external work done during expansion is

$$W = \frac{PV - pv}{n - 1} = \frac{(PV - pv)(l + sc)}{k + sc - l - sc} = (PV - pv) \left(\frac{l + sc}{k - l} \right) = (T - t)(l + sc),$$

from which the equation already given may be derived.

MODIFICATIONS IN IRREVERSIBLE PROCESSES

124. Constrained and Free Expansion. In Art. 86 it was assumed that the path of the substance was one involving changes of volume *against a resistance*. Such changes constitute *constrained expansion*. In this preliminary analysis, they are assumed to take place slowly, so that no mechanical work is done by reason of the velocity with which they are effected. When a substance expands against no resistance, as in Joule's experiment, or against a comparatively slight resistance, we have what is known as *free expansion*, and the external work is wholly or partly due to velocity changes.

125. Reversibility. All of the polytropic curves which have thus far been discussed exemplify constrained expansion. The external and internal pressures at any state, as in Art. 86, differ to an infinitesimal extent only; the quantities are therefore in finite terms equal, and the processes may be worked *at will in either direction*. A polytropic path having a finite exponent is in general, then, **reversible**, a characteristic of fundamental importance. During the adiabatic process which occurred in Joule's experiment, the externally resisting pressure was zero while the internal pressure of the gas was finite. The process could not be reversed, for it would be impossible for the gas to flow against a pressure greater than its own. The generation of heat by friction, the absorption of heat by one body from another, etc., are more familiar instances of *irreversible process*. Since these actions take place to a greater or less extent in all actual thermal phenomena, *it is impossible for any actual process to be perfectly reversible*. "A process affecting two substances is reversible only when the conditions existing at the commencement of the process may be directly restored without compensating changes in other bodies."

126. Irreversible Expansion. In Fig. 41, let the substance expand unconstrainedly, as in Joule's experiment, from *a* to *b*, this expansion being produced by the sudden decrease in external pressure when the stopcock is opened. Along the path *ab*, there is a violent movement of the particles of gas; the kinetic energy thus evolved is transformed into pressure at the end of the expansion, causing a rise of pressure to *c*. The gain or loss of internal energy depends solely upon the states *a, c*; the external work done does not depend on the irreversible path *ab*, for with a zero resisting pressure *no external work is done*. The theorem of Art. 86 is true *only for reversible operations*.

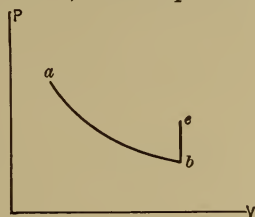

FIG. 41. Art. 126.—Irreversible Path.

127. Irreversible Adiabatic Process. Careful consideration should be given to unconstrained adiabatic processes like those exemplified in Joule's experiment. In that instance, the temperature of the gas was kept up by the transformation back to heat of the velocity energy of the rapidly moving particles, through the medium of friction. We have here a special case of heat absorption. No heat was received *from without*; the gas remained in a heat-insulated condition. While the process conforms to the adiabatic definition (Art. 83), it involves an action not contemplated when that definition was framed, viz., a reception of heat, not from sur-

rounding bodies, but *from the mechanical action of the substance itself*. The fundamental formula of Art. 12 thus becomes

$$H = T + I + W + V,$$

in which V may denote a mechanical effect due to the velocity of the particles of the substance. This subject will be encountered later in important applications (Arts. 175, 176, 426, 513).

FURTHER APPLICATION OF THE KINETIC THEORY

127 a. The Two Specific Heats. The equation has been derived (Art. 55),

$$pv = \frac{W}{3g} \cdot w^2 = \frac{M}{3} \cdot w^2,$$

in which p = the specific pressure exerted by a gas on its bounding surfaces;

v = the aggregate volume (not the specific volume) of the gas,

W = the weight of the gas, whence $\frac{v}{W}$ = its specific volume,

M = its mass,

w = the average velocity of all of the molecules of the gas.

The kinetic theory asserts that the absolute temperature is proportional to the mean kinetic energy per molecule. In a gas without intermolecular attractions the application of heat at unchanged volume can only add to the kinetic energy of molecular vibration. In passing between the temperatures t_1 and t_2 , then, the expenditure of heat may be written

$$H_1 = \frac{Mw_2^2}{2} - \frac{Mw_1^2}{2} = \frac{M}{2} (w_2^2 - w_1^2). \quad (A)$$

If the operation is performed at constant pressure instead of constant volume the expenditure of heat will be greater, by the amount of heat consumed in performing external work, $p(v_2 - v_1)$. From Charles' law,

$$\frac{v_2}{v_1} = \frac{t_2}{t_1} = \frac{Mw_2^2}{2} \div \frac{Mw_1^2}{2} = \left(\frac{w_2}{w_1}\right)^2.$$

Then

$$\frac{v_2}{v_1} - 1 = \left(\frac{w_2}{w_1}\right)^2 - 1;$$

$$v_2 - v_1 = v_1 \left(\frac{w_2^2 - w_1^2}{w_1^2}\right).$$

The external work is then

$$p(v_2 - v_1) = \frac{Mw_1^2}{3v_1} \cdot v_1 \left(\frac{w_2^2 - w_1^2}{w_1^2}\right) = \frac{M}{3} (w_2^2 - w_1^2), \quad (B)$$

and the total heat expended is

$$H_k = A + B = \frac{5M}{6} (w_2^2 - w_1^2). \quad (C)$$

If we divide C by A , we obtain

$$y = \frac{H_k}{H_1} = \frac{5M}{6} + \frac{M}{2} = \frac{10}{6} = 1.667,$$

which would be the ratio of the specific heats for a perfect monatomic gas. In such a gas, the molecules are relatively far apart, and move in straight lines. In a polyatomic gas (in which each molecule consists of more than one atom), there are interattractions and repulsions among the atoms which make up the molecule. Clausius has shown that the ratio of the intramolecular to the "straight line" or translational energy is constant for a given gas. If we call this ratio m , then for the polyatomic gas

$$H_l = (1 + m) \frac{M}{2} (w_2^2 - w_1^2)$$

$$H_k = (1 + m) \frac{M}{2} (w_2^2 - w_1^2) + \frac{M}{3} (w_2^2 - w_1^2)$$

$$= \frac{M}{6} (5 + 3m)(w_2^2 - w_1^2).$$

$$y = \frac{H_k}{H_l} = \frac{2M}{6} \frac{(5 + 3m)}{M(1 + m)} = \frac{5 + 3m}{3 + 3m}.$$

If $m = 0$, this becomes $\frac{5}{3}$, as for the monatomic gas. The equation gives also, $m = \frac{5 - 3y}{3y - 3}$. For oxygen, with $y = 1.4$, $m = \frac{5 - 4.2}{4.2 - 3} = \frac{0.8}{1.2} = 0.667$.

127 b. Some Applications. Writing the first equation given in the form

$$w^2 = \frac{3 p v g}{W} = 3 R t g,$$

we have for 1 lb. of air at standard conditions

$$w_a = \sqrt{3 \times 53.36 \times 492 \times 32.2} = 1593 \text{ ft. per second,}$$

the velocity of the air molecule. Noting also that $w = (f) \sqrt{v}$ under standard conditions, we obtain for hydrogen

$$w_h = 1593 \sqrt{\frac{178.83}{12.387}} = 6270 \text{ ft. per second.}$$

These are mean velocities. Some of the molecules are moving more rapidly, some more slowly.

The molecular velocities of course increase with the temperature and are higher for the lighter gases. A mixture of gases inclosed in a vessel containing an orifice, or in a porous container, will lose its lighter constituents first; because, since their molecular velocities are higher, their molecules will have briefer periods of oscillation from side to side of the containing vessel and will more frequently strike the pores or orifices and escape. This principle explains the commercial separation of mixed gases by the process of *osmosis*.

In any actual (polyatomic) gas, the molecules move in paths of constantly changing direction, and consequently do not travel far. The *diffusion* or perfect mixture of two or more gases brought together is therefore not an instantaneous process. High temperatures expedite it, and it is relatively more rapid with the lighter gases.

We may assume that intramolecular energy is related to a rotation of atoms about some common center of attraction. The intramolecular energy has been shown to be proportional to the temperature. A temperature may be reached at which the total energy of an atomic system may be so greatly increased that the

system itself will be broken up, atoms flying off perhaps to form new bonds, new molecules, new substances. This breaking up of molecules is called *dissociation*. In forming new atomic bonds, heat may be generated; and when this generation of heat occurs with sufficient rapidity, the process becomes self-sustaining; *i.e.* the temperature will be kept up to the dissociation point without any supply of heat from extraneous sources. If, as in many cases, the generation of heat is less rapid than this, dissociation of the atoms will cease after the external source of heat has been removed.

According to a theorem in analytical mechanics,* there is an initial velocity, easily computed, at which any body projected directly upward will escape from the sphere of gravitational attraction and never descend. For earth conditions, this velocity is, irrespective of the weight of the body, 6.95 miles per second = 36,650 ft. per second, ignoring atmospheric resistance. Now there is little doubt that some of the molecules of the lighter gases move at speeds exceeding this; so that it is quite possible that these lighter gases may be gradually escaping from our planet. On a small asteroid, where the gravitational attraction was less, much lower velocities would suffice to liberate the molecules, and on some of these bodies there could be no atmosphere, because the velocity at which liberation occurs is less than the normal velocities of the nitrogen and oxygen molecules.

(1) *Thermodynamics*, 1907, p. 18. (2) Alexander, *Treatise on Thermodynamics*, 1893, p. 105. (3) Wormell, *Thermodynamics*, 123; Alexander, *Thermodynamics*, 103; Rankine, *The Steam Engine*, 249, 321; Wood, *Thermodynamics*, 71-77, 437. (4) Zeuner, *Technical Thermodynamics*, Klein tr., I, 156. (5) Ripper, *Steam Engine Theory and Practice*, 1895, 17.

SYNOPSIS OF CHAPTER V

Pressure, volume and temperature as *thermodynamic coördinates*.

Thermal line, the locus of a series of successive states; *path*, a projected thermal line.

Paths: *isothermal*, constant temperature; *isodynamic*, constant internal energy; *adiabatic*, no transfer of heat to or from surrounding bodies.

The geometrical representation of the characteristic equation is a *surface*.

The *PV* diagram: subtended areas represent *external work*; a *cycle* is an enclosed figure; its *area* represents *external work*; it represents also the *net expenditure of heat*.

The *isothermal*: $pv^n = c$, in which $n = 1$, an equilateral hyperbola; the external work done is equivalent to the heat absorbed, $= pv \log_e \frac{V}{v}$: with a perfect gas, it *coincides with the isodynamic*.

Paths in general: $pv^n = c$; external work $= \frac{pv - PV}{n - 1}$; $\frac{t}{T} = \left(\frac{v}{V}\right)^{1-n}$; $\frac{T}{t} = \left(\frac{P}{p}\right)^{\frac{n-1}{n}}$.

The *adiabatic*: the external work done is equivalent to the expenditure of internal energy; $pv^\gamma = c$; $\gamma = 1.402$; computation from the velocity of sound in air; wave velocities with extreme pressure changes.

The heat absorbed along any path is represented by the area between that path and the two projected adiabatics; representation of k and l .

* See, for example, Bowser's *Analytic Mechanics*, 1908, p. 301.

Isadiabatics : $n_1 = n_2$; equal specific heats ; equality of property ratios.

Rankine's derivation of Joule's law : *the change of internal energy between two states is independent of the path.*

Apparatus for determining the value of y from pressure changes alone.

Along any path $pv^n = c$, the heat absorbed is $l(t - T) \left(\frac{y - n}{n - 1} \right)$; the mean specific heat is $l \frac{n - y}{n - 1}$. Such paths are called *polytropics*. Values of n and s for various paths.

Graphical method for determining the value of n ; *Brauer's method* for plotting polytropics ; the tabular method.

Graphical representations of internal energy ; representations of the sources of external work and of the effects of heat ; finite area representing heat expenditure.

Polytropic expansion in ordnance.

Irreversible processes : constrained and free expansion ; reversibility ; no actual process is reversible ; example of irreversible process ; subtended areas do not represent external work ; in adiabatic action, heat may be received from the mechanical behavior of *the substance itself* ; $H = T + I + W + V$; further applications of the kinetic theory.

Use of Hyperbolic Functions : Tyler's Method. Given $x^m = a$, let $x^m = e^s$. Then $m \log_e x = s$ and $x^m = e^{m \log_e x}$. Adopting the general forms

$$\begin{aligned} e^t &= \cosh t + \sinh t, \\ e^{-t} &= \cosh t - \sinh t, \end{aligned}$$

we have

$$\begin{aligned} x^m &= \cosh (m \log_e x) + \sinh (m \log_e x), \text{ where } m \log_e x \text{ is positive ;} \\ x^m &= \cosh (m \log_e x) - \sinh (m \log_e x), \text{ where } m \log_e x \text{ is negative.} \end{aligned}$$

If now we have a table of the sums and differences of the hyperbolic functions, and a table of hyperbolic logarithms, we may practically without computation obtain the value of x^m . Thus, take the expression

$$\left(\frac{14.7}{114.7} \right)^{0.29}.$$

Here $x = 0.1281$, $m = 0.29$, $m \log_e x = -0.596$, $(\cosh - \sinh) m \log_e x = 0.552$. The limits of value of x may be fixed, as in the preceding article, as 0 and 1.0. For $x = 0$, $m \log_e x = -\infty$, and the method would require too extended a table of hyperbolic functions. But if we use the general form in which $x > 1.0$ and usually < 10.0 , $m \log_e x$ will rarely exceed 10.0, and the method is practicable.

For a fuller discussion, with tables, see paper by Tyler in the *Polytechnic Engineer*, 1912.

NOTES ON LOGARITHMS

Definitions; $\log x$ or com $\log x = n$, where $10^n = x$.

$\log_e x = m$ where $e^m = x$, $e = 2.7183 +$.

$\log_e x = (2.3026) \log x$.

Characteristic and Mantissa; the log consists of a *characteristic*, integral and either positive or negative; and a *mantissa*, a positive fraction or decimal. Dividing or multiplying a number by 10 or any multiple thereof changes the characteristic of the log, but not its mantissa. Thus,

	<i>Characteristic</i>	<i>Mantissa</i>		
$\log 2 =$	0	0.30103	written	0.30103
$\log 20 =$	1	0.30103	written	1.30103
$\log 200 =$	2	0.30103	written	2.30103
$\log 0.2 =$	-1	0.30103	written	$\bar{1}.30103$
			and equivalent to	-0.69897
$\log 0.02 =$	-2	0.30103	written	$\bar{2}.30103$
			and equivalent to	-1.69897

Operations with logarithms:

$$\log (a \times b) = \log a + \log b. \quad \text{Remember also:}$$

$$\log (a \div b) = \log a - \log b. \quad \frac{1}{x^n} = \sqrt[n]{x}.$$

$$\log (a)^n = n \log a. \quad x^{-n} = \frac{1}{x^n}.$$

$$\log (a)^{\frac{1}{n}} = \log \sqrt[n]{a} = \frac{\log a}{n}.$$

Negative sign: the signs of negative characteristics must be carefully considered. Thus, to find the value of $0.02^{-0.37}$:

$$\begin{aligned} \log 0.02 &= \bar{2}.30103 = -2.0 + 0.30103. \\ -0.37 \log 0.02 &= -0.37(-2.0 + 0.30103) = 0.74 - 0.1114 = 0.6286. \\ &= \log (4.252 = 0.02^{-0.37}). \end{aligned}$$

When the final logarithm comes out negative, it must be converted into logarithmic form (negative characteristic and positive mantissa) by adding and subtracting 1. Thus $-0.6286 = \bar{1}.3714 = \log 0.2352$.

For example, to find the value of $0.02^{0.37}$:

$$\begin{aligned} \log 0.02 &= \bar{2}.30103 = -2.0 + 0.30103 \\ 0.37 \log 0.02 &= 0.37(-2.0 + 0.30103) = -0.74 + 0.1114 = -0.6286 = \bar{1}.3714 \\ &= \log (0.2352 = 0.02^{0.37}). \end{aligned}$$

PROBLEMS

1. On a perfect gas diagram, the coördinates of which are internal energy and volume, construct an isodynamic, an isothermal, and an isometric path through E (internal energy) = 2, $V = 2$.

2. Plot accurately the following: on the TV diagram,* an adiabatic through $T = 270$, $V = 10$; an isothermal through $T = 300$, $V = 20$; on the TP † diagram, an adiabatic through $T = 230$, $P = 5$; an isothermal through $T = 190$, $P = 30$. On the EV diagram, ‡ show the shape of an adiabatic path through $E = 240$, $V = 10$.

3. Show the isometric path of a perfect gas on the PT plane; the isopiestic, on the VT plane.

4. Sketch the TV path of wax from 0° to 290° F., assuming the melting point to be 90° , the boiling point 290° , that wax expands in melting, and that its maximum density *as liquid* is at the melting point.

5. A cycle is bounded by two isopiestic paths through $P = 110$, $P = 100$ (pounds per square foot), and by two isometric paths through $V = 20$, $V = 10$ (cubic feet). Find the heat expended by the working substance. (*Ans.*, 0.1285 B. t. u.)

6. Air expands isothermally at 32° F. from atmospheric pressure to a pressure of 5 lb. absolute § per square inch. Find its specific volume after expansion. (*Ans.*, 36.42 cu. ft.)

7. Given an isothermal curve and the OV axis; find graphically the OP axis.

8. Prove the correctness of the construction described in Art. 93.

9. Find the heat absorbed during the expansion described in Problem 6. (*Ans.*, 36.31 B. t. u.)

10. Find the specific heat for the path $PV^{1.2} = c$, for air and for hydrogen. (*Ans.*, air, -0.1706 ; hydrogen, -2.54 .)

11. Along the path $PV^{1.2} = c$, find the external work done in expanding from $P = 1000$, $V = 10$, to $V = 100$. Find also the heat absorbed, and the loss of internal energy, if the substance is one pound of air. Units are *pounds per square foot* and *cubic feet*. (*Ans.*, $W = 18,450$ ft.-lb.; $H = 11,796$ B. t. u.; $E_1 - E_2 = 11.8$ B. t. u.)

12. A perfect gas is expanded from $p = 400$, $v = 2$, $t = 1200$, to $P = 60$, $V = 220$. Find the final temperature. (*Ans.*, $19,800^\circ$ abs.)

13. Along the path $PV^{1.2} = c$, a gas is expanded to ten times its initial volume of 10 cubic feet per pound. The initial pressure being 1000, and the value of R 53.36, find the final pressure and temperature. (See Problem 11.) (*Ans.*, $p = 63.1$ lb. per sq. ft., $t = 118.25^\circ$ abs.)

14. Through what range of temperature will air be heated if compressed to 10 atmospheres from normal atmospheric pressure and 70° F., following the law $pv^{1.3} = c$? What will be the rise in temperature if the law is $pvv = c$? If it is $pv = c$? (*Ans.*, a , 371.3° ; b , 495° ; c , 0° .)

$$* \frac{T}{t} = \left(\frac{V}{v}\right)^{1-n} \quad \dagger \frac{T}{t} = \left(\frac{P}{p}\right)^{\frac{n-1}{n}} \quad \ddagger \frac{E}{e} = \left(\frac{V}{v}\right)^{1-n}$$

§ Absolute pressures are pressures measured above a perfect vacuum. The absolute pressure of one standard atmosphere is 14.697 lb. per square inch.

15. Find the heat imparted to one pound of this air in compressing it as described according to the law $pv^{1.3}=c$, and the change of internal energy.

(Ans., $H_2-H_1=-21.6$ B. t. u.; $E_2-E_1=63.1$ B. t. u.)

16. In Problem 14, after compression along the path $pv^{1.3}=c$, the air is cooled at constant volume to 70°F. , and then expanded along the isodiabatic path to its initial volume. Find the pressure and temperature at the end of this expansion.

(Ans., $p=8.64$ lb. per sq. in., $t=311^\circ\text{abs.}$)

17. The isodiabatics ab ; cd , are intersected by lines of constant volume ac , bd .

Prove $\frac{P_a}{P_c}=\frac{P_b}{P_d}$ and $\frac{T_a}{T_c}=\frac{T_b}{T_d}$.

18. In a room at normal atmospheric pressure and constant temperature, a cylinder contains air at a pressure of 1200 lb. per square inch. The stopcock on the cylinder is suddenly opened. After the pressure in the cylinder has fallen to that of the atmosphere, the cock is closed, and the cylinder left undisturbed for 24 hours. Compute the pressure in the cylinder at the end of this time.

(Ans., 51.94 lb. per sq. in.)

19. Find graphically the value of n for the polytropic curve ab , Fig. 41.

20. Plot by Brauer's method a curve $pv^{1.8}=26,200$. Use a scale of 1 inch per 4 units of volume and per 80 units pressure. Begin the curve with $p=1000$.

21. Supply the necessary figures in the following blank spaces, for $n=1.8$, and apply the results to check the curve obtained in Problem 20. Begin with $v=6.12$, $p=1000$.

$$\frac{V}{v}=2.0, 2.25, 2.50, 3.0, 4.0, 5.0, 6.0, 7.0, 8.0$$

$$\log \frac{p}{P}=n \log \frac{V}{v} =$$

$$\frac{p}{P} =$$

$$P =$$

22. The velocity of sound in air being taken at 1140 ft. per second at 70°F. and normal atmospheric pressure, compute the value of γ for air. (Ans., 1.4293.)

23. Compute the latent heat of expansion (Art. 58) of air from atmospheric pressure and at 32°F. (Ans., 2.615 B. t. u.)

24. Find the amount of heat converted into work in a cycle 1234, in which $P_1=P_4=100$, $V_1=5$, $V_4=1$, $P_3=30$ (all in lb. per sq. ft.), and the equations of the paths are as follows: for 41, $PV^0=c$; for 12, $PVv=c$; for 32, $PV=c$; for 43, $PV^{1.8}=c$. The working substance is one pound of air. Find the temperatures at the points 1, 2, 3, 4.

(Ans., $\Sigma H=1.386$ B. t. u.; $T_1=9.37^\circ$; $T_3=1.097^\circ$; $T_2=1.097^\circ$; $T_4=1.874^\circ$.)

25. Find the exponent of the polytropic path, for air, along which the specific heat is $-k$. Also that along which it is $-l$. Represent these paths, and the amounts of heat absorbed, graphically, comparing with those along which the specific heats are k and l , and show how the diagram illustrates the meaning of *negative specific heat*.

(Ans., for $s=-k$, $n=1.167$; for $s=-l$, $n=1.201$.)

26. A gas, while undergoing compression, has expended upon it 38,900 ft. lb. of work; meanwhile, it loses to the atmosphere 20 B. t. u. of heat. What change occurs in its internal energy?

27. One pound of air under a pressure of 150 lb. per sq. in. occupies 4 cu. ft. What is its temperature? How does its internal energy compare with that at atmospheric pressure and 32° F.?

28. Three cubic feet of air expand from 300 to 150 lb. pressure per square inch, at constant temperature. Find the values of H , E and W .

29. How much work must be done to compress 1000 cu. ft. of normal air to a pressure of ten atmospheres, at constant temperature? How much heat must be removed during the compression?

30. Air is compressed in a water-jacketed cylinder from 1 to 10 atmospheres; its specific volume being reduced from 13 to 2.7 cu. ft. How much work is consumed per cubic foot of the original air?

31. Let $p=200$, $v=3$, $P=100$, $V=5$. Find the value of n in the expression $pv^n = PV^n$.

32. Draw to scale the PT and TV representations of the cycle described in Prob. 24.

33. A pipe line for air shows pressures of 200 and 150 lb. per square inch and temperatures of 160° and 100° F., at the inlet and outlet ends, respectively. What is the loss of internal energy of the air during transmission? If the pipe line is of uniform size, compare the velocities at its two ends.

34. If air is compressed so that $pv^{1.35} = c$, find the amount of heat lost to the cylinder walls of the compressor, the temperature of the air rising 150° F. during compression.

CHAPTER VI

THE CARNOT CYCLE

x **128. Heat Engines.** In a heat engine, work is obtained from heat energy through the medium of a gas or vapor. Of the total heat received by such fluid, a portion is lost by conduction from the walls of containing vessels, a portion is discharged to the atmosphere after the required work has been done, and a third portion *disappears*, having been converted into external mechanical work. By the first law of thermodynamics, this third portion is equivalent to the work done; it is the *only heat actually used*. The *efficiency* of a heat engine is the ratio of the net heat utilized to the total quantity of heat supplied to the engine, or, of external work done to gross heat absorbed; to $\frac{W}{H} = \frac{H-h}{H}$, in which h denotes the quantity of heat *rejected* by the engine, if radiation effects be ignored.

129. Cyclic Action. In every heat engine, the working fluid passes through a series of successive states of pressure, volume, and temperature; and, in order that operation may be continuous, it is necessary either that the fluid work in a closed cycle which may be repeated indefinitely, or that a fresh supply of fluid be admitted to the engine to compensate for such quantity as is periodically discharged. It is convenient to regard the latter more usual arrangement as equivalent to the former, and in the first instance to study the action of a constant body of fluid, conceived to work continuously in a closed cycle.

130. Forms of Cycle. The several paths described in Art. 83, and others less commonly considered, suggest various possible forms of cycle, some of which are illustrated in Fig.

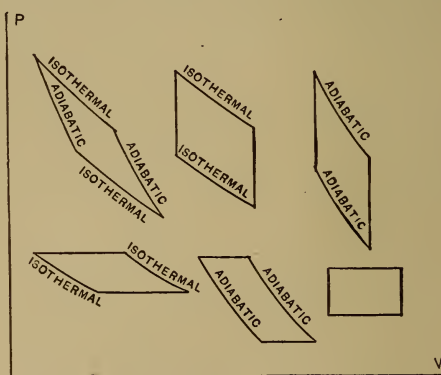

FIG. 42. Art. 130, Problem 2.—Possible Cycles.

42. Many of these have been given names (1). The *isodiabatic* cycle, bounded by two isothermals and any two isodiabatics (Art. 108), may also be mentioned.

131. Development of the Carnot Cycle. Carnot, in 1824, by describing and analyzing the action of the perfect elementary heat engine, effected one of the most important achievements of modern physical science (2). Carnot, it is true, worked with insufficient data. Being ignorant of the first law of thermodynamics, and holding to the caloric theory, he asserted that no heat was lost during the cyclic process; but, though to this extent founded on error, his main conclusions were correct. Before his death, in 1832, Carnot was led to a more just conception of the true nature of heat; while, left as it was, his work has been the starting point for nearly all subsequent investigations. The Carnot engine is the limit and standard for all heat engines.

Clapeyron placed the arguments of Carnot in analytical and graphical form; Clausius expressed them in terms of the mechanical theory of heat; James Thompson, Rankine, and Clerk Maxwell corrected Carnot's assumptions, redescribed the cyclic process, and redetermined the results; and Kelvin (3) expressed them in their final and satisfactory modern form.

132. Operation of Carnot's Cycle. Adopting Kelvin's method, the operation on the Carnot engine may be described by reference to Fig. 43. A working *piston* moves in the *cylinder c*, the walls of

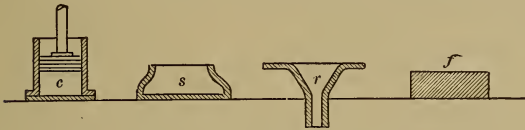

FIG. 43. Arts. 132, 138.—Operation of the Carnot Cycle.

which are non-conducting, while the head is a perfect conductor. The piston itself is a non-conductor and moves without friction. The body *s* is an *infinite source of heat* (the *furnace*, in an actual power plant) maintained constantly at the temperature T , no matter how much heat is abstracted from it. At *r* is an infinite *condenser*, capable of receiving any quantity of heat whatever without undergoing any elevation of temperature above its initial temperature t . The plate *f* is assumed to be a perfect non-conductor. The fluid in the cylinder is assumed to be initially at the temperature T of the source.

The cylinder is placed on *s*. Heat is received, but the temperature does not change, since both cylinder and source are at the same temperature. *External work is done*, as a result of the reception of heat; the piston rises. When this operation has continued for some time, the cylinder is instantaneously transferred to the non-conducting plate *f*. The piston is now allowed to rise from the expansion produced by a *decrease of the internal energy* of the fluid. It continues to rise until the temperature of the fluid has fallen to t ,

that of the condenser, when the cylinder is instantaneously transferred to *r*. *Heat is now given up by the fluid to the condenser, and the piston falls; but no change of temperature takes place.* When this action is completed (the point for completion will be determined later), the cylinder is again placed on *f*, and the piston allowed to fall further, increasing the internal energy and temperature of the gas by compressing it. This compression is continued until the temperature of the fluid is T' and the piston is again in its initial position, when the cylinder is once more placed upon *s* and the operation may be repeated. No actual engine could be built or operated under these assumed conditions.

133. Graphical Representation. The first operation described in the preceding is *expansion at constant temperature*. The path of the fluid is then an *isothermal*. The second operation is expansion *without transfer of heat*, external work being done at the expense of the internal energy; the path is consequently *adiabatic*. During the third operation, we have *isothermal compression*; and during the fourth, *adiabatic compression*. The Carnot cycle may then be represented by *abcd*, Fig. 44.

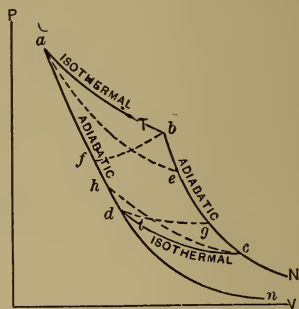

FIG. 44. Arts. 133-136, 138, 142.
The Carnot Cycle.

134. Termination of Third Operation. In order that the adiabatic compression *da* may bring the fluid back to its initial conditions of pressure, volume, and temperature, the isothermal compression *cd* must be terminated at a suitable point *d*. From Art. 99,

$$\frac{T}{t} = \left(\frac{V_a}{V_d} \right)^{1-\gamma} \text{ for the adiabatic } da,$$

and

$$\frac{T}{t} = \left(\frac{V_b}{V_c} \right)^{1-\gamma} \text{ for the adiabatic } bc;$$

hence

$$\frac{V_a}{V_d} = \frac{V_b}{V_c} \text{ and } \frac{V_a}{V_b} = \frac{V_d}{V_c};$$

that is, the ratio of volumes during isothermal expansion in the first stage must be equal to the ratio of volumes during isothermal compression in the third stage, if the final adiabatic compression is to complete the cycle. (Compare Art. 108.)

✧ **135. Efficiency of Carnot Cycle.** The only transfers of heat during this cycle occur along *ab* and *cd*. The heat absorbed along *ab* is

$P_a V_a \log_e \frac{V_b}{V_a} = RT \log_e \frac{V_b}{V_a}$. Similarly, along cd , the heat rejected is $Rt \log_e \frac{V_c}{V_d}$. The net amount of heat transformed into work is the difference of these two quantities; whence the **efficiency**, defined in Art. 128 as the ratio of the net amount of heat utilized to the total amount of heat absorbed, is

$$\frac{R \left(T \log_e \frac{V_b}{V_a} - t \log_e \frac{V_c}{V_d} \right)}{RT \log_e \frac{V_b}{V_a}} = \frac{T-t}{T}, \text{ since } \frac{V_b}{V_a} = \frac{V_c}{V_d}, \text{ from Art. 134.}$$

X 136. **Second Derivation.** The external work done under the two adiabatics bc , da is

$$\frac{P_b V_b - P_c V_c}{y-1} \text{ and } \frac{P_a V_a - P_d V_d}{y-1}.$$

Deducting the negative work from the positive, the net adiabatic work is

$$\frac{P_b V_b - P_c V_c - P_a V_a + P_d V_d}{y-1},$$

but $P_a V_a = P_b V_b$, from the law of the isothermal ab ; similarly, $P_d V_d = P_c V_c$, and consequently this net work is equal to zero; and if we express efficiency by the ratio of work done to gross heat absorbed, we need consider *only the work areas under the isothermal curves ab and cd* , which are given by the numerator in the expression of Art. 135.

The efficiency of the Carnot engine is therefore expressed by the ratio of the difference of the temperatures of source and condenser to the absolute temperature of the source.

137. **Carnot's Conclusion.** The computations described apply to any substance in uniform thermal condition; hence the conclusion, now universally accepted, that the motive power of heat is independent of the agents employed to develop it; it is determined solely by the temperatures of the bodies between which the cyclic transfers of heat occur.

138. **Reversal of Cycle.** The paths which constitute the Carnot cycle, Fig. 44, are polytropic and *reversible* (Art. 125); the cycle itself is reversible. Let the cylinder in Fig. 43 be first placed upon r , and the piston allowed to rise. Isothermal expansion occurs. The cylinder is transferred to f and the piston caused to fall, producing adiabatic compression. The cylinder is then placed on s , the piston still falling, resulting in isothermal compression; and finally on f , the piston being allowed to rise, so as to produce adiabatic expansion. Heat has now been *taken* from the

condenser and *rejected* to the source. The cycle followed is *debad*, Fig. 44. **Work has been expended upon the fluid; the heat delivered to the source s is made up of the heat taken from the condenser r , plus the heat equivalent of the work done upon the fluid.** The apparatus, instead of being a heat engine, is now a sort of **heat pump**, transferring heat from a cold body to one warmer than itself, by reason of the **expenditure** of external work. Every operation of the cycle has been reversed. The same quantity of heat originally taken from s has now been given up to it; the quantity of heat originally imparted to r is now taken from it; and the amount of external work originally done by the fluid has now been expended upon it. The *efficiency*, based on our present definition, may exceed unity; it is the quotient of *heat imparted to the source by work expended*. The cylinder c must in this case be initially at the temperature t of the condenser r .

139. Criterion of Reversibility. Of all engines working between the same limits of temperature, that which is reversible is the engine of maximum efficiency.

If not, let A be a more efficient engine, and let the power which this engine develops be applied to the driving of a *heat pump* (Art. 138), (which *is* a reversible engine), and let this heat pump be used for restoring heat to a source s for operating engine A . Assuming that there is no friction, then engine A is to perform just a sufficient amount of work to drive the heat pump. In generating this power, engine A will consume a certain amount of heat from the source, depending upon its efficiency. If this efficiency is greater than that of the heat pump, the latter will *discharge more heat than the former receives* (see explanation of efficiency, Art. 138); or will continually restore more heat to the source than engine A removes from it. This is a result contrary to all experience. It is impossible to conceive of any self-acting machine which shall continually produce heat (or any other form of energy) without a corresponding consumption of energy from some other source.

140. Hydraulic Analogy. The absurdity may be illustrated, as by Heck (4), by imagining a water motor to be used in driving a pump, the pump being employed to deliver the water back to the upper level which supplies the motor. Obviously, the motor would be doing its best if it consumed no more water than the pump returned to the reservoir; no better performance can be imagined, and with actual motors and pumps this performance would never even be equaled. Assuming the pump to be equally efficient as a motor or as a pump (*i.e. reversible*), the motor cannot possibly be more efficient.

141. Clausius' Proof. The validity of this demonstration depends upon the correctness of the assumption that perpetual motion is impossible. Since the im-

possibility of perpetual motion cannot be directly demonstrated, Clausius established the criterion of reversibility by showing that the existence of a more efficient engine A involved the continuous transference of heat from a cold body to one warmer than itself, *without the aid of external agency*: an action which is axiomatically impossible.

142. The Perfect Elementary Heat Engine. It follows from the analysis of Art. 135 that all engines working in the Carnot cycle are equally efficient; and from Art. 139 that the Carnot engine is one of *that class of engines* of highest efficiency. The Carnot cycle is therefore described as that of the **perfect elementary heat engine**. It remains to be shown that among reversible engines working between equal temperature limits, that of Carnot is of maximum efficiency. Consider the Carnot cycle $abcd$, Fig. 44. The external work done is $abcd$, and the efficiency, $abcd \div nabN$. For any other reversible path than ab , like ae or fb , touching the same line of maximum temperature, the work area $abcd$ and the heat absorption area $nabN$ are reduced by equal amounts. The ratio expressing efficiency is then reduced by equal amounts in numerator and denominator, and since the value of this ratio is always fractional, its value is thus always reduced. For any other reversible path than cd , like ch or gd , touching the same line of minimum temperature, the work area is reduced without any reduction in the gross heat area $nabN$. Consequently the Carnot engine is that of maximum efficiency among all conceivable engines worked between the same limits of temperature. A practical cycle of equal efficiency will, however, be considered (Art. 257).

143. Deductions. The efficiency of an actual engine can therefore never reach 100 per cent, since this, even with the Carnot engine, would require t in Art. 135 to be equal to absolute zero. High efficiency is conditioned upon a wide range of working temperatures; and since the minimum temperature cannot be maintained below that of surrounding bodies, high efficiency involves practically the highest possible temperature of heat absorption. Actual heat engines do not work in the Carnot cycle; but their efficiency nevertheless depends, though less directly, on the temperature range. With many working substances, high temperatures are necessarily associated with high specific pressures, imposing serious constructive difficulties. The limit of engine efficiency is thus fixed by the possibilities of mechanical construction.

Further, an ordinary steam boiler furnace may develop a maximum temperature, during combustion, of 3000° F. If the lowest available temperature surrounding is 0° F., the potential efficiency is $\frac{3000}{3000 + 460} = 0.87$. But in getting the heat from the hot gases to the steam the temperature usually falls to about 350° F. Although 70 or 80 per cent of the energy originally in the fuel may be present in the steam, the availability of this energy for doing work in an engine has now been

decreased to $\frac{350}{350+460}=0.43$, or about one-half. (A boiler is of course not a heat engine.)

(1) Alexander, *Treatise on Thermodynamics*, 1893, 38-40. (2) Carnot's *Reflections* is available in Thurston's translation or in Magie's *Second Law of Thermodynamics*. An estimate of his part in the development of physical science is given by Tait, *Thermodynamics*, 1868, 44. (3) *Trans. Roy. Soc. Edinburgh*, March, 1851; *Phil. Mag.*, IV, 1852; *Math. and Phys. Papers*, I, 174. (4) *The Steam Engine*, I, 50.

SYNOPSIS OF CHAPTER VI

Heat engines: efficiency = $\frac{\text{heat utilized} + \text{heat absorbed}}{H} = \frac{W}{H}$.

Cyclic action: closed cycle; forms of cycle.

Carnot cycle: historical development; cylinder, source, insulating plate, condenser;

graphical representation; termination of third operation, when $\frac{V_d}{V_c} = \frac{V_a}{V_b}$; efficiency = $\frac{T-t}{T}$.

Carnot's conclusion: efficiency is independent of the working substance.

Reversal of cycle: the reversible engine is that of maximum efficiency; hydraulic analogy.

Carnot cycle not surpassed in efficiency by any reversible or irreversible cycle.

Limitations of efficiency in actual heat engines.

PROBLEMS

1. Show how to express the efficiency of any heat-engine cycle as the quotient of two areas on the PV diagram.

2. Draw and explain six forms of cycle not shown in Fig. 42.

3. In a Carnot cycle, using air, the initial state is $P = 1000$, $V = 100$. The pressure after isothermal expansion is 500, the temperature of the condenser 200°F . Find the pressure at the termination of the "third operation," the external work done along each of the four paths, and the heat absorbed along each of the four paths. Units are cubic feet per pound and pounds per square foot.

$$\begin{aligned} \text{Ans. } p_3 &= 13.1; W_{12} = 69,237 \text{ ft. lb.}; H_{12} = 88.94 \text{ B. t. u.}; \\ W_{23} &= 161,200 \text{ ft. lb.}; H_{23} = 0; \\ W_{34} &= 24,368 \text{ ft. lb.}; H_{34} = 31.32 \text{ B. t. u.}; \\ W_{41} &= 161,200 \text{ ft. lb.}; H_{41} = 0. \end{aligned}$$

4. A non-reversible heat engine takes 1 B. t. u. per minute from a source and is used to drive a heat pump having an efficiency (quotient of work by heat imparted to source) of 0.70. What would be the rate of increase of heat contents of the source if the efficiency of the heat engine were 0.80? (Ans., 0.143 B. t. u. per min.)

5. Ordinary non-condensing steam engines use steam at 325°F . and discharge it to the atmosphere at 215°F . What is their maximum possible efficiency?

(Ans., 0.142.)

6. Find the limiting efficiency of a gas engine in which a maximum temperature of 3000°F . is attained, the gases being exhausted at 1000°F . (*Ans.*, 0.578.)

7. An engine consumes 225 B. t. u. per indicated horse-power (33,000 foot-pounds) per minute. If its temperature limits are 430°F . and 105°F ., how closely does its efficiency approach the best possible efficiency? (*Ans.*, 51.59 per cent.)

8. How many B. t. u. per indicated horse power per hour would be required by a heat engine having an efficiency of 15 per cent?

9. A power plant uses 2 lb. of coal (14,000 B. t. u. per lb.) per kilowatt-hour. (1 kw. = 1.34 h.p.) What is its efficiency from fuel to switchboard?

10. A steam engine working between 350°F . and 100°F . uses 15 lb. of steam containing 1050 B. t. u. per lb., per indicated horse power per hour. What proportion of the heat supplied was utilized by the engine? How does this proportion compare with the highest that might have been attained?

11. Determine as to the credibility of the following claims for an oil engine:

Temperature limits, 3000°F . and 1000°F .

Fuel contains 19,000 B. t. u. per lb. Engine consumes 0.35 lb. per kw.-hr.

Loss between cylinder and switchboard, 20 per cent.

12. If the engine in Problem 3 is double-acting, and makes 100 r.p.m., what is its horse power?

CHAPTER VII

THE SECOND LAW OF THERMODYNAMICS

144. Statement of Second Law. The expression for efficiency of the Carnot cycle, given in Art. 135, is a statement of the **second law of thermodynamics**. The law is variously expressed; but, in general, it is *an axiom from which is established the criterion of reversibility* (Art. 139).

With Clausius, the axiom was,

(a) "*Heat cannot of itself pass from a colder to a hotter body;*" while the equivalent axiom of Kelvin was,

(b) "*It is impossible, by means of inanimate material agency, to derive mechanical effect from any portion of matter by cooling it below the temperature of the coldest of surrounding objects.*"

With Carnot, the axiom was that *perpetual motion is impossible*; while Rankine's statement of the second law (Art. 151) is an analytical restatement of the efficiency of the Carnot cycle.

145. Comparison of Laws. The *law of relation* of gaseous properties (Art. 10) and the *second law of thermodynamics* are justified by their results, while the *first law of thermodynamics* is an expression of experimental fact. The second law is a "definite and independent statement of an axiom resulting from the choice of one of the two propositions of a dilemma" (1). For example, in Carnot's form, we must admit either the possibility of perpetual motion or the criterion of reversibility; and we choose to admit the latter. The second law is not a proposition to be proved, but an "axiom commanding universal assent when its terms are understood."

146. Preferred Statements. The simplest and most satisfactory statement of the second law may be derived directly from inspection of the formula for efficiency, $(T - t) \div T$ (Art. 135). The most general statement,

(c) "*The availability of heat for doing work depends upon its temperature*" leads at once to the axiomatic forms of Kelvin and Clausius; while the most specific of all the statements directly underlies the presentation of Rankine:

(d) "If all of the heat be absorbed at one temperature, and rejected at another lower temperature, the heat transformed to

external work is to the total heat absorbed in the same ratio as that of the difference between the temperatures of absorption and rejection to the absolute temperature of absorption ;” or,

$$\frac{H - h}{H} = \frac{T - t}{T},$$

in which H represents heat absorbed ; and h , heat rejected.

147. Other Statements. Forms (a), (b), (c), and (d) are those usually given the second law. In modified forms, it has been variously expressed as follows :

(e) “All reversible engines working between the same uniform temperatures have the same efficiency.”

(f) “The efficiency of a reversible engine is independent of the nature of the working substance.”

(g) “It is impossible, by the unaided action of natural processes, to transform any part of the heat of a body into mechanical work, except by allowing the heat to pass from that body into another at lower temperature.”

(h) “If the engine be such that, when it is worked backward, the physical and mechanical agencies in every part of its motions are reversed, it produces as much mechanical effect as can be produced by any thermodynamic engine, with the same source and condenser, from a given quantity of heat.”

148. Harmonization of Statements. It has been asserted that the statements of the second law by different writers involve ideas so diverse as, apparently, not to cover a common principle. A moment’s consideration of Art. 144 will explain this. The second law, in the forms given in (a), (b), (c), (g), is an axiom, from which the criterion of reversibility is established. In (d), (e) (f), it is a simple statement of the efficiency of the Carnot cycle, with which the axiom is associated ; while in (h), it is the criterion of reversibility itself. Confusion may be avoided by treating the algebraic expression of (d), Art. 146, as a sufficient statement of the second law, from which all necessary applications may be derived.

149. Consequences of the Second Law. Some of these were touched upon in Art. 143. The first law teaches that heat and work are mutually convertible, the second law shows *how much* of either may be converted into the other under stated conditions. Ordinary condensing steam engines work between temperatures of about 350° F. and 100° F. The maximum possible efficiency of such engines is therefore

$$\frac{350 - 100}{350 + 459.4} = 0.31.$$

The efficiencies of actual steam engines range from $2\frac{1}{2}$ to 25 per cent, with an average probably not exceeding 7 to 10 per cent. A steam engine seems therefore a most inefficient machine; but it must be remembered that, of the total heat supplied to it, a large proportion is (by the second law) unavailable for use, and *must be rejected* when its temperature falls to that of surrounding bodies. We cannot expect a water wheel located in the mountains to utilize all of the head of the water supply, measured down to sea level. The available head is limited by the elevation of the lowest of surrounding levels. The performance of a heat engine should be judged by its approach to the efficiency of the Carnot cycle, rather than by its absolute efficiency.

Heat must be regarded as a "low unorganized" form of energy, which produces useful work only by undergoing a fall of temperature. All other forms of energy tend to completely transform themselves into heat. As the universe slowly settles to thermal equilibrium, the performance of work by heat becomes impossible and all energy becomes permanently degenerated to its most unavailable form.*

150. Temperature Fall and Work Done. Consider the Carnot cycle, *abcd*, Fig. 45, the total heat absorbed being $nabN$ and the efficiency $abcd \div nabN$

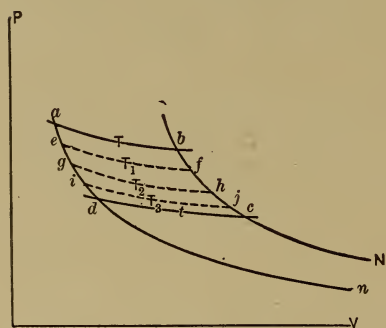

FIG. 45. Arts. 150, 153, 154, 156.—Second Law of Thermodynamics.

$= (T-t) \div T$. Draw the isothermals *ef*, *gh*, *ij*, successively differing by equal temperature intervals; and let the temperatures of these isothermals be T_1 , T_2 , T_3 . Then the work done in cycle *abfe* is $nabN \times (T - T_1) \div T$; that in cycle *abhg* is $nabN \times (T - T_2) \div T$; that in cycle *abji* is $nabN \times (T - T_3) \div T$. As $(T - T_3) = 3(T - T_1)$ and $(T - T_2) = 2(T - T_1)$, $abji = 3(abfe)$ and $abhg = 2(abfe)$; whence $abfe = efhg = ghji$.

In other words, the external work available from a definite temperature fall is the same at all parts of the thermometric scale. The waterfall analogy of Art. 149 may again be instructively utilized.

151. Rankine's Statement of the Second Law. "If the total actual heat of a uniformly hot substance be conceived to be divided into any number of equal parts, the effects of those parts in causing work to be performed are equal. If we remember that by "total actual heat" Rankine means the heat corresponding to absolute temperature, his terse statement becomes a form of that just derived, dependent solely upon the computed efficiency of the Carnot cycle.

152. Absolute Temperature. It is convenient to review the steps by which the proposition of Art. 150 has been established. We have derived a conception of absolute temperature from the law of Charles, and have found that the efficiency of the Carnot cycle bears a certain relation to definite absolute temperatures.

* "Each time we alter our investment in energy, we have thus to pay a commission, and the tribute thus exerted can never be wholly recovered by us and must be regarded, *not* as destroyed, but as thrown on the waste-heap of the Universe."—Griffiths.

Our scale of absolute temperatures, practically applied, is not entirely satisfactory; for the absolute zero of the air thermometer, -459.4° F., is not a true absolute zero, because air is not a perfect gas. The logical scale of absolute temperature would be that in which temperatures were defined by reference to the work done by a reversible heat engine. Having this scale, we should be in a position to compute the coefficient of expansion of a perfect gas.

153. Kelvin's Scale of Absolute Temperature. Kelvin, in 1848, was led by a perusal of Carnot's memoir to propose such a scale. His first definition, based on the caloric theory, resulted only in directing general attention to Carnot's great work; his second definition is now generally adopted. Its form is complex, but the conception involved is simply that of Art. 150:

"The absolute temperatures of two bodies are proportional to the quantities of heat respectively taken in and given out in localities at one temperature and at the other, respectively, by a material system subjected to a complete cycle of perfectly reversible thermodynamic operations, and not allowed to part with or take in heat at any other temperature." Briefly,

"The absolute values of two temperatures are to each other in the proportion of the quantities of heat taken in and rejected in a perfect thermodynamic engine, working with a source and condenser at the higher and the lower of the temperatures respectively." Symbolically,

$$\frac{T}{t} = \frac{H}{h}; \text{ or, in Fig. 45, } \frac{T}{t} = \frac{nabN}{ndcN}.$$

This relation may be obtained directly by a simple algebraic transformation of the equation for the second law, given in Art. 146, (d).

154. Graphical Representation of Kelvin's Scale. Returning to Fig. 45, but ignoring the previous significance of the construction, let ab be an isothermal and an , bN adiabatics. Draw isothermals ef , gh , ij , such that the areas $abfe$, $efhg$, $ghji$ are equal. Then if we designate the temperatures along ab , ef , gh , ij by T , T_1 , T_2 , T_3 , the temperature intervals $T - T_1$, $T_1 - T_2$, $T_2 - T_3$ are equal. If we take ab as 212° F., and cd as 32° F., then by dividing the intervening area into 180 equal parts, we shall have a true Fahrenheit absolute scale. Continuing the equal divisions down below cd , we should reach a point at which the last remaining area between the indefinitely extended adiabatics was just equal to the one next preceding, provided that the temperature 32° F. could be expressed in an even number of absolute degrees.

155. Carnot's Function. Carnot did not find the definite formula for efficiency of his engine, given in Art. 135, although he expressed it as a function of the temperature range ($T - t$). We may state the efficiency as

$$e = z(T - t),$$

z being a factor having the same value for all gases. Taking the general expression for efficiency, $\frac{H-h}{H}$ (Art. 128), and making $H = h + dh$, we have

$$e = \frac{h + dh - h}{h + dh} = \frac{dh}{h + dh}.$$

For $e = z(T - t)$, we may write $e = zdt$ or $z = \frac{e}{dt}$, giving

$$z = \frac{dh}{h + dh} \div dt, \text{ equivalent to } \frac{dh}{Hdt}.$$

But $\frac{T}{t} = \frac{H}{h}$ (Art. 153); whence $\frac{t + dt}{t} = \frac{h + dh}{h}$ and $\frac{dt}{t} = \frac{dh}{h}$, and $t = \frac{hdt}{dh} = \frac{1}{z}$.

Then $z = \frac{1}{t}$ and $e = \frac{T-t}{t} = \frac{T-t}{T}$ in finite terms, as already found. The factor z is known as *Carnot's function*. It is the *reciprocal of the absolute temperature*.

156. Determination of the Absolute Zero. The porous plug experiments conducted by Joule and Kelvin (Art. 74) consisted in forcing various gases slowly through an orifice. The fact has already been mentioned that when this action was conducted without the performance of external work, a barely noticeable change in temperature was observed; this being with some gases an increase, and with others a decrease. *When a resisting pressure was applied at the outlet of the orifice, so as to cause the performance of some external work during the flow of gas, a fall of temperature was observed; and this fall was different for different gases.*

The "porous plug" was a wad of silk fibers placed in the orifice for the purpose of reconverting all energy of velocity back to heat. Assume a slight fall of temperature to occur in passing the plug, the velocity energy being reconverted to heat at the decreased temperature, giving the equivalent paths ad, dc , Fig. 45. Then expend a sufficient measured quantity of work to bring the substance back to its original condition a , along cba . By the second law,

$$\frac{T}{nabN} = \frac{T_1}{nefN} = \frac{T_1}{nabN - abfe}, \text{ and } \frac{T}{T_1} = \frac{nabN}{nabN - abfe};$$

$$\text{or } T - T_1 = T_1 \left(\frac{nabN}{nabN - abfe} - 1 \right) = T_1 \frac{abfe}{nabN - abfe}.$$

If $(T - T_1)$ as determined by the experiment = a , and $nabN$ be put equal to unity,

$$T_1 = \frac{a(1 - abfe)}{abfe},$$

in which $abfe$ is the work expended in bringing the gas back to its original temperature. This, in outline, was the Joule and Kelvin method for establishing a location for the true absolute zero: the complete theory is too extensive for presentation here (2). The absolute temperature of melting ice is on this scale 491.58° F. or 273.1° C.

The agreement with the hydrogen or the air thermometer is close. The correction for the former is generally less than $\frac{1}{100}$ ° C., and that for

the latter less than $\frac{1}{10}^{\circ}$ C. Wood has computed (3) that the true absolute zero must necessarily be slightly lower than that of the air thermometer. According to Alexander, (4) the difference of the two scales is constant for all temperatures. The Kelvin absolute scale establishes a logical definition of temperature as a physical unit. Actual gas thermometer temperatures may be reduced to the Kelvin scale as a final standard.

In the further discussion, the temperature -459.6° F. will be regarded as the absolute zero. (5)

(1) Peabody, *Thermodynamics*, 1907, 27. (2) *Phil. Trans.*, CXIV, 349. (3), *Thermodynamics*, 1905, 116. (4) *Treatise on Thermodynamics*, 1892, 91. (5) See the papers, *On the Establishment of the Thermodynamic Scale of Temperature by Means of the Constant Pressure Thermometer*, by Buckingham; and *On the Standard Scale of Temperature in the Interval 0° to 100° C.*, by Waidner and Dickinson; *Bulletin of the Bureau of Standards*, 3, 2; 3, 4. Also the paper by Buckingham, *On the Definition of the Ideal Gas*, op. cit., 6, 3.

SYNOPSIS OF CHAPTER VII

Statements of the second law: *an axiom* establishing the criterion of reversibility; $\frac{H-h}{H} = \frac{T-t}{T}$ or $\frac{h}{H} = \frac{t}{T}$, a statement of the efficiency of the Carnot cycle; the criterion of reversibility itself.

The second law limits the possible efficiency of a heat engine.

The fall of temperature determines the amount of external work done.

Temperature ratios defined as equal to ratios of heats absorbed and emitted.

The Carnot function for cyclic efficiency is the reciprocal of the absolute temperature.

The absolute zero, based on the second law, is at -459.6° F.

PROBLEMS

1. Illustrate graphically the first and the second laws of thermodynamics. Frame a new statement of the latter.

2. An engine works in a Carnot cycle between 400° F. and 280° F., developing 120 h.p. If the heat rejected by this engine is received at the temperature of rejection by a second Carnot engine, which works down to 220° F., find the horse power of the second engine. (*Ans.*, 60).

3. Find the coefficient of expansion at constant pressure of a perfect gas. What is the percentage difference between this coefficient and that for air?

(*Ans.*, 0.0020342; percentage difference, 0.03931.)

4. A Carnot engine receives from the source 1000 B. t. u., and discharges to the condenser 500 B. t. u. If the temperature of the source is 600° F., what is the temperature of the condenser? (*Ans.*, 70.2° F.)

5. A Carnot engine receives from the source 190 B. t. u. at 1440.4° F., and discharges to the condenser 90 B. t. u. at 440.4° F. Find the location of the absolute zero. (*Ans.*, -459.6° F.)

6. In the porous plug experiment, the initial temperature of the gas being that of

melting ice, and the fall of temperature being $\frac{1}{180}$ of the range from melting to boiling of water at atmospheric pressure, the work expended in restoring the initial temperature was 1.58 foot-pounds. Find the absolute temperature at 32° F. (*Ans.*, 492.39°.)

7. The temperature range in a Carnot cycle being 400° F., and the work done being equivalent to 40 per cent of the amount of heat rejected, find the values of T and t .

REVIEW PROBLEMS, CHAPTERS I-VII

1. State the precise meaning, or the application, of the following expressions:

k 778 l $\left(\frac{P}{p}\right)_v = \frac{T}{t}$ $H = T + I + W$ r y E 53.36 $PV = RT \cdot R$ -459.6° F.

I 778 P V T $\frac{dH}{dT}$ $pv \log_e \frac{V}{v}$ $\frac{pv - PV}{n-1}$ $\frac{pv - PV}{y-1}$ $\left(\frac{P}{p}\right)^{\frac{n-1}{n}} = \frac{T}{t}$ $\left(\frac{V}{v}\right)^{1-n} = \frac{T}{t}$
 $pv^n = c$ 42.42 $pv^y = c$ 2545 $pv = c$ $s = l \frac{n-y}{n-1}$

2. A heat engine receives its fluid at 350° F. and discharges it at 110° F. It consumes 200 B. t. u. per Ihp. per minute. Find its efficiency as compared with that of the corresponding Carnot cycle. (*Ans.*, 0.712.)

3. Given a cycle abc , in which $P_a = P_b = 100$ lb. per sq. in., $V_a = 1$, $\frac{V_b}{V_a} = 6$ (cu. ft.), $P_b V_b^{1.8} = P_c V_c^{1.8}$, $P_a V_a = P_c V_c$, find the pressure, volume, and temperature at c if the substance is 1 lb. of air. (*Ans.*, $p_c = 1.758$, $v_c = 53.34$, $t_c = 269.9^\circ$ abs.)

4. Find the pressure of 100 lb. of air contained in a 100 cu.-ft. tank at 82° F. (*Ans.*, 28,900 lb. per sq. ft.)

5. A heat engine receives 1175.2 B. t. u. in each pound of steam and rejects 1048.4 B. t. u. It uses 3110 lb. of steam per hour and develops 142 hp. Estimate the value of the mechanical equivalent of heat. (*Ans.*, -712.96.)

6. One pound of air at 32°F. is compressed from 14.7 to 2000 lb. per square inch without change of temperature. Find the percentage change of volume. (*Ans.*, 99.3 %.)

7. Prove that the efficiency of the Carnot cycle is $\frac{T-t}{T}$.

8. Air is heated at constant pressure from 32° F. to 500° F. Find the percentage change in its volume. (*Ans.*, 95.2 % increase.)

9. Prove that the change of internal energy in passing from a to b is independent of the path ab .

10. Given the formula for change of internal energy, $\frac{P_b V_b - P_a V_a}{y-1}$, prove that $E_b - E_a = l(T_b - T_a)$.

11. Given R for air = 53.36, $V = 12.387$; and given $V = 178.8$, $k = 3.4$ for hydrogen: find the value of y for hydrogen. (*Ans.*, 1.412.)

12. Explain isothermal, adiabatic, isodynamic, isodiabatic.

13. Find the mean specific heat along the path $pv^{1.8} = c$ for air ($l = 0.1689$). (*Ans.*, 0.084.)

14. A steam engine discharging its exhaust at 212° F. receives steam containing 1100 B. t. u. per pound at 590° F. What is the minimum weight of steam it may use per Ihp.-hr.? (*Ans*, 7.71 lb.)

15. A cycle is bounded by polytropic paths 12, 23, 13. We have given

$$P_1 = P_2 = 100,000 \text{ lb. per sq. ft.}$$

$$V_2 = V_3 = 40 \text{ cubic feet per pound.}$$

$$T_1 = 3000^{\circ} \text{ F.}$$

$$P_1 V_1 = P_3 V_3.$$

Find the amount of heat converted to work in the cycle, if the working substance is air. (*Ans.*, 4175 B. t. u.)

CHAPTER VIII

ENTROPY

157. Adiabatic Cycles. Let $abcd$, Fig. 46, be a Carnot cycle, an and bN the projected adiabatics. Draw intervening adiabatics em , gM , etc., so located that the areas $naem$, $megM$, $MgbN$, are equal. Then since the efficiency of each of the cycles $aefc$, $eghf$, $gbdh$, is $(T - t) \div T$, the work areas represented by these cycles are all equal. To measure these areas by mechanical means would lead to approximate results only.

158. Rectangular Diagram. If the adiabatics and isothermals were straight lines, simple arithmetic would suffice for the measurement of the work areas of Fig. 46. We have seen that in the Carnot cycle, bounded by isothermals and adiabatics, $\frac{H}{T} = \frac{h}{t}$ (Art. 153). Applying this formula to Rankine's theorem (Art. 106), we have the quotient of an area and a length as a constant. If the area h is a part of H , then there must be some constant property, which, when multiplied by the temperatures T or t , will

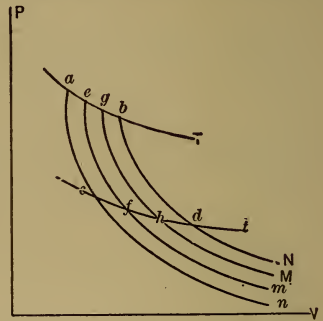

FIG. 46. Arts. 157, 158, 159, 160.—Adiabatic Cycles.*

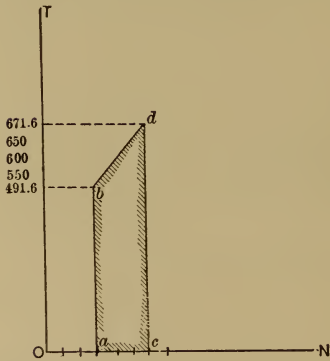

FIG. 47. Arts. 158, 163, 171.—Entropy Diagram.

give the areas H or h . Let us conceive of a diagram in which only one coördinate will at present be named. That coördinate is to be *absolute temperature*. Instead of specifying the other coördinate, let it be assumed that subtended areas on this diagram are to denote quantities of heat absorbed or emitted, just as such areas on the PV diagram represent external work done. As an example of such a diagram, consider Fig. 47. Let the substance be one

* The adiabatics are distorted for clearness. In reality they are asymptotic. Many of the diagrams throughout the book are similarly "out of drawing" for the same reason.

pound of water, initially at a temperature of 32° F., or 491.6° absolute, represented by the height ab , the horizontal location of the state b being taken at random. Now assume the water to be heated to 212° F., or 671.6° absolute, the specific heat being taken as constant and equal to unity. The heat gained is 180 B. t. u. The final temperature of the water fixes the vertical location of the new state point d , *i.e.* the length of the line cd . Its horizontal location is fixed by the consideration that *the area subtended between the path bd and the axis which we have marked ON shall be 180 B. t. u.* The horizontal distance ac may be computed from the properties of the trapezoid $abdc$ to be equal to the area $abdc$ divided by $[(ab + cd) \div 2]$ or to $180 \div [(491.6 + 671.6) \div 2] = 0.31$. The point d is thus located (Art. 163).

159. Application to a Carnot Cycle. Ordinates being absolute temperatures, and areas subtended being quantities of heat absorbed or emitted, we may conclude that *an isothermal must be a straight horizontal line*; its temperature is constant, and a finite amount of heat is transferred. If the path is from left to right, heat is to be

conceived as *absorbed*; if from right to left, heat is *rejected*. Along a (reversible) adiabatic, no movement of heat occurs. The only line on this diagram which does not subtend a finite area is a straight vertical line. *Adiabatics are consequently vertical straight lines.* (But see Art. 176.) The temperature must constantly change along an adiabatic.

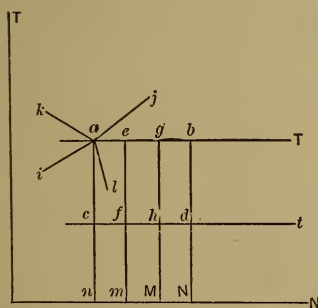

FIG. 48. Arts. 159, 160, 161, 163, 166. — Adiabatic Cycles, Entropy Diagram.

The lengths of all isothermals drawn between the same two adiabatics are equal.

The Carnot cycle on this new diagram

may then be represented as a rectangle enclosed by vertical and horizontal lines; and in Fig. 48 we have a new illustration of the cycles shown in Fig. 46, all of the lines corresponding.

160. Physical Significance. The new diagram is to be conceived as so related to the PV diagram of Fig. 46 that while an imaginary

pencil is describing any stated path on the latter, a corresponding pencil is tracing its path on the former. In the PV diagram, the subtended areas constantly represent *external work* done by or on the substance; in the new diagram they represent *quantities of heat* absorbed or rejected. (Note, however, Art. 176.) The area of the closed cycle in the first case represents the *net quantity of work done*; in the second, it represents the *net amount of heat lost*, and consequently, also, the net work done. But *subtended areas under a single path* on the PV diagram do not represent *heat* quantities, nor in the new diagram do they represent *work* quantities. **The validity of the diagram is conditioned upon the absoluteness of the properties chosen as coördinates.** We have seen that temperature is a cardinal property, irrespective of the previous history of the substance; and it will be shown that this is true also of the horizontal coördinate, so that we may legitimately employ a diagram in which these two properties are the coördinates.

161. Polytropic Paths. For any path in which the specific heat is zero, the transfer of heat is zero, and the path on this diagram is, consequently vertical, an adiabatic. For specific heat equal to infinity, the temperature cannot change, and the path is horizontal, an isothermal. For any *positive* value of the specific heat, heat area and temperature will be gained or lost simultaneously; the path will be similar to ai or aj , Fig. 48. If the specific heat is *negative*, the temperature will increase with rejection of heat, or decrease with its absorption, as along the paths ak , al , Fig. 48. These results may be compared with those of Art. 115. Figure 49 shows on the new diagram the paths corresponding with those of Fig. 31. It may be noted that, in general, though not invariably, increases of

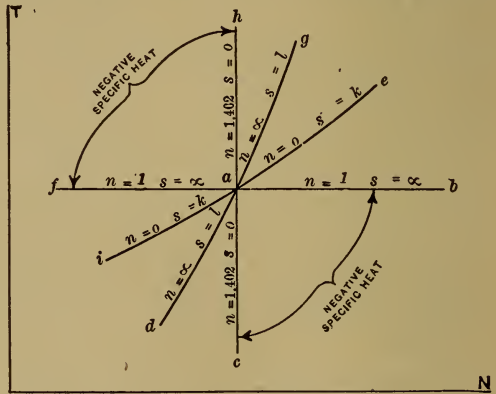

FIG. 49. Arts. 161, 165.—Polytropic Paths on Entropy Diagram.

Figure 49 shows on the new diagram the paths corresponding with those of Fig. 31. It may be noted that, in general, though not invariably, increases of

volume are associated with increases of the horizontal coördinate of the new diagram.

162. Justification of the Diagram. In the PV diagram of Fig. 50, consider the cycle $ABCD$. Let the heat absorbed along a portion of this cycle be represented by the infinitesimal strips $nabN$,

$NbcM$, $Mcdm$, formed by the indefinitely projected adiabatics. In any one of these strips, as $nabN$, we have, in finite terms,

$$\frac{nabN}{negN} = \frac{T'}{t}, \text{ or } \frac{nabN}{T} = \frac{negN}{t}.$$

Considering the whole series of strips from A to C , we have

$$\sum \frac{nabN}{T} = \sum \frac{negN}{t},$$

or, using the symbol H for heat transferred,

$$\sum \frac{dH}{T} = 0,$$

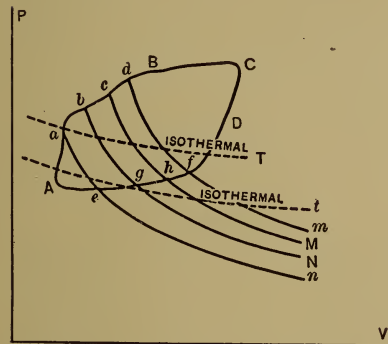

Fig. 50. Art. 162.—Entropy a Cardinal Property.

in which T expresses temperature generally.

Let the substance complete the cycle $ABCD A$; we then have, *the paths being reversible*,

$$\int_A^D \frac{dH}{T} = \int_B^C \frac{dH}{T} + \int_C^A \frac{dH}{T} = 0;$$

while for the cycle $ADCDA$,

$$\int_A^D \frac{dH}{T} = \int_D^C \frac{dH}{T} + \int_C^A \frac{dH}{T} = 0;$$

whence,

$$\int_A^C \frac{dH}{T} = \int_B^C \frac{dH}{T}.$$

The integral $\int \frac{dH}{T}$ thus has the same value whether the path is ADC or ABC ,

or, indeed, any reversible path between A and C ; its value is *independent of the path of the substance*. Now this integral will be shown immediately to be the most general expression for the horizontal coördinate of the diagram under discussion.

Since it denotes a *cardinal property*, like pressure or temperature, it is permissible to use a diagram in which the coördinates are T and $\int \frac{dH}{T}$.

163. Analytical Expression. Along any path of constant temperature, as ab , Fig. 48, the horizontal distance nN may be computed from the expression, $nN = H \div T$, in which H represents the quantity of heat absorbed, and T the temperature of the isothermal. If the temperature varies, the horizontal component of the path during the absorption of dH units of heat is $dn = dH \div T$. For any path along which the *specific heat is constant*, and equals k , $kdT = dH$,

$$dn = \frac{kdT}{T}, \text{ and } n = k \int_t^T \frac{dT}{T} = k \log_e \frac{T}{t}.$$

If the specific heat is variable, say $k = a + bT$, then

$$n = \int_t^T (a + bT) \frac{dT}{T} = a \log_e \frac{T}{t} + b(T - t).$$

The line bd of Fig. 47 is then a logarithmic curve, not a straight line; and the method of finding it adopted in Art. 158 is strictly accurate only for an infinitesimal change of temperature. Writing the expression just derived in the form $n = k \log_e (T \div t)$ and remembering that $T = PV \div R$, while $t = pv \div R$, we have

$$n = k \log_e (PV \div pv).$$

The expression $k \log_e (T \div t)$ is the one *most commonly used for calculating values of the horizontal coördinate for polytropic paths*. The expression $dn = dH \div T$ is general for all reversible paths and is regarded by Rankine as the **fundamental equation of thermodynamics**.

164. Computation of Specific Heat. If at any point on a reversible path a tangent be drawn, the length of the subtangent on the N -axis represents the value of the specific heat at that point. In Fig. 51, draw the tangent nm to the curve AB at the point n and construct the infinitesimal triangle $dt dn$. From similar triangles, $mr : nr :: dn : dt$,

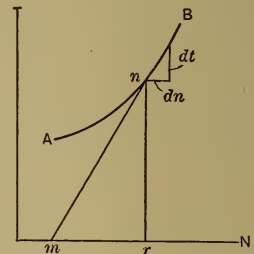

FIG. 51. Art. 164.—Graphical Determination of Specific Heat.

or $mr = Tdn \div dt = dH \div dt = s$ (Art. 112).

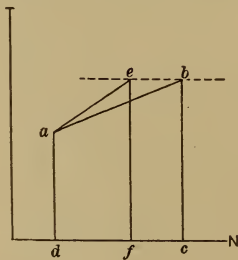

FIG. 52. Art. 165.—Comparison of Specific Heats.

165. Comparison of Specific Heats. If a gas is heated at constant pressure from a , Fig. 52, it will gain heat and temperature, following some such path as ab . If heated at constant volume, through an equal range of temperature, a less

quantity of heat will be gained; *i.e.* the subtended area *aefd* will be less than the area *abcd*. In general, the less the specific heat, the more nearly vertical will be the path. (Compare Fig. 49.) When $k=0$, the path is vertical; when $k=\infty$, the path is horizontal.

166. Properties of the Carnot Cycle. In Fig. 48, it is easy to see that since efficiency is equal to net expenditure of heat divided by gross expenditure, the ratio of the areas *abdc* and *abNn* expresses the efficiency, and that this ratio is equal to $(T-t) \div T$. The cycle *abdc* is obviously the most efficient of all that can be inscribed between the limiting isothermals and adiabatics.

167. Other Deductions. The net enclosed area on the *TN* diagram represents the *net movement of heat*. That this area is always equivalent to the corresponding enclosed area on the *PV* diagram is a statement of the **first law of thermodynamics**. Two statements of the **second law** have just been derived (Art. 166). The theorem of Art. 106, relating to the representation of heat absorbed by the area between the adiabatics, is accepted upon inspection of the *TN* diagram. That of Art. 150, from which the Kelvin absolute scale of temperature was deduced, is equally obvious.

168. Entropy. The horizontal or *N* coördinate on the diagram now presented was called by Clausius the **entropy** of the body. It may be mathematically defined as the ratio $n = \int \frac{dH}{T}$. Any physical definition or conception should be framed by each reader for himself. Wood calls entropy "that property of the substance which remains constant throughout the changes represented by a [reversible] adiabatic line." It is for this reason that reversible adiabatics are called isentropics, and that we have used the letters *n*, *N* in denoting adiabatics.

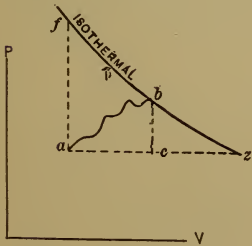

FIG. 54. Arts. 169, 329a.—
Change of Entropy.

169. General Formulas. It must be thoroughly understood that the validity of the entropy diagram is dependent upon the fact that *entropy is a cardinal property*, like pressure, volume, and temperature. For this reason it is desirable to become familiar with computations of change of entropy irrespective of the path pursued. Otherwise, the method of Art. 163 is usually more convenient.

Consider the states *a* and *b*, Fig. 54. Let the substance pass at constant pressure to *c* and thence at constant volume

to *b*. The entropy increases by $k \log_e \frac{T_c}{T_a} + l \log_e \frac{T_b}{T_c}$ (Art. 163), k and l in this instance denoting the respective special values of the specific heats. An equivalent expression arises from Charles' law:

$$n = k \log_e \frac{V_c}{V_a} + l \log_e \frac{P_b}{P_c} = k \log_e \frac{V_b}{V_a} + l \log_e \frac{P_b}{P_a}, \quad (\text{A})$$

in which last the final and initial states only are included.

We may also write,

$$\begin{aligned} n &= l \log_e \frac{T_f}{T_a} + \frac{P_f V_f \log_e \frac{V_b}{V_f}}{T_f}, \text{ Arts. 94, 95, 163,} \\ &= l \log_e \frac{T_b}{T_a} + (k-l) \log_e \frac{V_b}{V_a}, \text{ Arts. 51, 65:} \end{aligned} \quad (\text{B})$$

and further,

$$\begin{aligned} n &= k \log_e \frac{T_z}{T_a} + (k-l) \log_e \frac{V_b}{V_z} \\ &= k \log_e \frac{T_b}{T_a} + (k-l) \log_e \frac{P_a}{P_b}. \end{aligned} \quad (\text{C})$$

The entropy is completely determined by the adiabatic through the state point. In the expression $n_1 = k_1 \log_e \frac{T}{t}$, the value of n_1 apparently depends upon that of k_1 , which is of course related to the path; along another path, the gain or loss of entropy might be $n_2 = k_2 \log_e \frac{T}{t}$, a different value; but although the temperatures would be the same at the beginning and end of both processes, the pressures or volumes would differ. The *states* would consequently be different, and the values of n should therefore differ also.

A graphical method for the transfer of perfect gas paths from the PV to the TN plane has been developed by Berry (1).

169a. Mixtures of Liquids. When m lb. of water are heated from 32° to t° absolute, the specific heat being taken at unity, the gain of entropy is

$$m \log_e \frac{t}{492}.$$

Let m lb. at t° be mixed with n lb. at t_1° , the resulting temperature of $(m+n)$ lb. being (from Art. 25), without radiation effects,

$$t_0 = \frac{nt_1 + mt}{m+n}.$$

This, if heated from 32° to t_0° , would have acquired the entropy

$$(m+n) \log_e \frac{t_0}{492},$$

and the change in aggregate entropy due to the mixture is

$$m \log_e \frac{t}{492} + n \log_e \frac{t_1}{492} - (m+n) \log_e \left(\frac{nt_1 + mt}{492(m+n)} \right).$$

The mixing of substances at different temperatures always increases the aggregate entropy. Thus, let a body of entropy n , at the temperature t , discharge a small amount, H , of its heat to an adjacent body of entropy N and temperature T . The aggregate entropy before the transfer is $n+N$; after the transfer it is

$$\left(n - \frac{H}{t} \right) + \left(N + \frac{H}{T} \right),$$

and since $t > T$, $\frac{H}{t} < \frac{H}{T}$ and the loss of entropy is less than the gain:

or

$$\left\{ \left(n - \frac{H}{t} \right) + \left(N + \frac{H}{T} \right) \right\} > (n+N).$$

170. Other Names for n . Rankine called n the **thermodynamic function**. It has been called the "heat factor." Zeuner describes it as "heat weight." It has also been called the "mass" of heat. The letters T , N , which we have used in marking the coördinates, were formerly replaced by the Greek letters *theta* and *phi*, indicating absolute temperatures and entropies; whence the name, *theta-phi diagram*. The TN diagram is now commonly called the **temperature-entropy diagram**, or, more briefly, the **entropy diagram**.

171. Entropy Units. Thus far, entropy has been considered as a horizontal distance on the diagram, without reference to any particular zero point. Its units are B. t. u. per degree of absolute temperature. Strictly speaking, entropy is merely a ratio, and has no dimensional units. *Changes* of entropy are alone of physical significance. The choice of a zero point may be made at random; there is no logical zero of entropy. A convenient starting point is to take the adiabatic of the substance through the state $P=2116.8$, $T=32^\circ$ F., as the OT axis, the entropy of this adiabatic being assumed to be zero, as in ordinary tables.

Thus, in Fig. 47 (Art. 158), the OT axis should be shifted to pass through the point b , which was located at random horizontally.

172. Hydraulic Analogy. The analogy of Art. 140 may be extended to illustrate the conception of entropy. Suppose a certain weight of water W to be maintained at a height H above sea level; and that in passing through a motor its level is reduced to h . The initial potential energy of the water may be regarded as WH ; the final residual energy as Wh ; the energy expended as $W(H - h)$. Let this operation be compared with that of a Carnot cycle, taking in heat at T and discharging it at t . Regarding heat as the product of N and T , then the heat energies corresponding to the water energies just described are NT , Nt , and $N(T - t)$; N being analogous to W , the *weight* of the water.

173. Adiabatic Equation. Consider the states 1 and 2, on an adiabatic path, Fig. 55. The change of entropy along the constant volume path 13

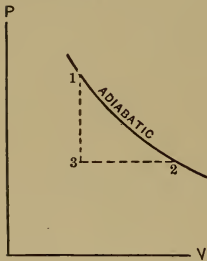

is $l \log_e \frac{T_3}{T_1}$; that along the constant pressure path 32

is $k \log_e \frac{T_2}{T_3}$. The difference of entropy between

1 and 2, irrespective of the path, is

$$l \log_e \frac{T_3}{T_1} + k \log_e \frac{T_2}{T_3} = l \log_e \frac{P_2}{P_1} + k \log_e \frac{V_2}{V_1}.$$

FIG. 55. Art. 173.—
Adiabatic Equation.

For a reversible adiabatic process, this is equal to zero; whence

$$l \log_e \frac{P_2}{P_1} = -k \log_e \frac{V_2}{V_1}, \text{ or } y \log_e V_2 + \log_e P_2 = y \log_e V_1 + \log_e P_1,$$

from which we readily derive $P_1 V_1^y = P_2 V_2^y$, the equation of the adiabatic.

174. Use of the Entropy Diagram. The intelligent use of the entropy diagram is of fundamental importance in simplifying thermodynamic conceptions. The mathematical processes formerly adhered to in presenting the subject have been largely abandoned in recent text-books, largely on account of the simplicity of illustration made possible by employing the TN coördinates.

Belpaire was probably the first to appreciate their usefulness. Gibbs, at about the same date, 1873, presented the method in this country and first employed as coördinates the three properties volume, entropy, and internal energy. Linde, Schroeter, Hermann, Zeuner, and Gray used TN diagrams prior to 1890. Cotterill, Ayrton and Perry, Dwelshauvers Dery and Ewing have employed them to a considerable extent. Detailed treatments of this thermodynamic method have been given by Boulvin, Reeve, Berry, and Golding (?). Some precautions necessary in its practical application are suggested in Arts. 454-458.

IRREVERSIBLE PROCESSES

175. Modification of the Entropy Conception. It is of importance to distinguish between reversible and irreversible processes in relation to entropy changes.

The significance of the term *reversible*, as applied to a *path*, was discussed in Art. 125. A *process* is reversible only when it consists of a series of successive states of thermal equilibrium. A series of paths constitute a *reversible process* only when they form a closed cycle, each path of which is itself reversible. The Carnot cycle is a perfect example of a reversible process. As an example of an *irreversible cycle*, let the substance, after isothermal expansion, as in the Carnot cycle, be transferred directly to the condenser. Heat will be abstracted, and the pressure may be reduced at constant volume, as along *bc*, Fig. 56. Then allow it to compress isothermally, as in the Carnot cycle, and finally to be transferred to the source, where the temperature and pressure increase at constant volume, as along *da*. This cycle cannot be operated in the reverse order, for the pressure and temperature cannot be reduced from *a* to *d* while the substance is in communication with the source, nor increased from *c* to *b* while it is in communication with the condenser.

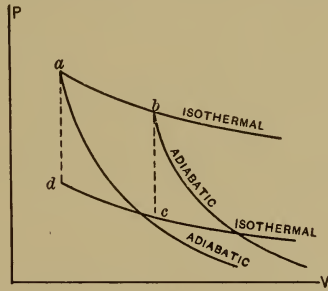

FIG. 56. Art. 175.—Irreversible Cycle.

176. Irreversibility in the Porous Plug Experiment. We have seen that in this instance of unresisted expansion, the fundamental formula of Art. 12 becomes $H = T + I + W + V$ (Art. 127). Knowing $H = 0$, $W = 0$, we may write $(T + I) = -V$, or *velocity is attained at the expense of the internal energy*. The velocity evidences *kinetic energy*; mechanical work is made possible; and we might expect an exhibition of such work and a fall of internal energy, and consequently of temperature. But we find no such utilization of the kinetic energy of the rapidly flowing jet; on the contrary, the gas is gradually brought to rest and the velocity derived from an expenditure of internal energy is *reconverted to internal energy*. The process was adiabatic, for no transfer of heat occurred; it was at the same time isothermal, for no change of temperature occurred; and while both adiabatic and isothermal, no external work was done, so that the *PV* diagram is invalid.

Further: the adiabatic path here considered was not isentropic, like an ordinary adiabatic. The area under the path on the *TN* diagram no longer represents heat absorbed from surrounding bodies. Neither does $dn = \frac{dH}{T}$, for H is zero, while n is finite. *The expression for increase of entropy, $\int \frac{dH}{T}$, along a reversible path, does not hold for irreversible operations.*

In irreversible operations, the expression $\int \frac{dH}{T}$ ceases to represent a cardinal property. We have the following propositions:

(a) In a reversible operation, the sum of the entropies of the participating substances is unchanged. During a reversible change, the temperatures of the heat-absorbing and heat-emitting bodies must differ to an infinitesimal extent only; they are in finite terms equal. The heat lost by the one body is equal to the heat gained by the other, so that the expression $\int \frac{dH}{T}$ denotes both the loss of entropy by the one substance and the gain by the other; the total stock of entropy remaining constant.

(b) During irreversible operations, the aggregate entropy increases. Consider two engines working in the Carnot cycle, the first taking the quantity of heat H_1 from the source, and discharging the quantity H_2 to the condenser; the second, acting as a heat pump (Art. 139), taking the quantity H_2' from the condenser and restoring H_1' to the source. Then if the work produced by the engine is expended in driving the pump, without loss by friction,

$$H_1 - H_2 = H_1' - H_2'.$$

If the engine is irreversible, $H_1 > H_1'$, or $H_1 - H_1' > 0$, whence, $H_2 - H_2' > 0$. If we denote by a a positive finite value, $H_1 = H_1' + a$ and $H_2 = H_2' + a$. But $\frac{H_1'}{H_2'} = \frac{T_1}{T_2}$, or $\frac{H_1'}{T_1} - \frac{H_2'}{T_2} = 0$, and consequently

$$\frac{H_1 - a}{T_1} - \frac{H_2 - a}{T_2} = 0, \text{ and } \frac{H_1}{T_1} - \frac{H_2}{T_2} = a \left(\frac{1}{T_1} - \frac{1}{T_2} \right).$$

Since $T_1 > T_2$, $\frac{H_1}{T_1} - \frac{H_2}{T_2} < 0$, or $\frac{H_2}{T_2} > \frac{H_1}{T_1}$, or, generally, $\int \frac{dH}{T} < 0$. The value of $\int \frac{dH}{T}$ is thus, for irreversible cyclic operations, negative.

Now let a substance work irreversibly from A to B , thence reversibly from B to A . We may write

$$\int_A^B \frac{dH}{T} + \int_B^A \frac{dH}{T} = \int_A^B \frac{dH}{T} - \int_A^B \frac{dH}{T} < 0. \quad (A)$$

(irrev.) (rev.) (irrev.) (rev.)

But the change of entropy of the substance in passing from A to B is $N_B - N_A = \int_A^B \frac{dH}{T}$, dH being the amount of heat absorbed along any reversible path, while the change of entropy of the source which supplies the substance with heat (reversibly) is $N_B' - N_A' = - \int_A^B \frac{dH}{T}$, the negative sign denoting that heat has been abstracted.

We have then, from equation (A),

$$-(N_B' - N_A') - (N_B - N_A) < 0; \text{ or, } (N_B + N_B') - (N_A + N_A') > 0;$$

i.e. the sum of the entropies of the participating substances increases when the process is irreversible.

(c) The loss of work due to irreversibility is proportional to the increase of entropy. Consider a partially completed cycle: one which might be made complete were all of the paths reversible. Let the heat absorbed be Q , at the temperature T , increasing the entropy of the substance by $\frac{Q}{T}$; and let its entropy be further increased

by $N' - N$ during the process. The total increase of entropy is then $n = N' - N + \frac{Q}{T}$, whence $Q = T(n - N' + N)$. The work done may be written as $H - H' + Q$, in which H and H' are the initial and final heat contents respectively. Calling this W , we have

$$W = H - H' + T(n - N' + N).$$

In a reversible cycle $\int \frac{dH}{T} = n = 0$; whence $W_R = H - H' + T(N - N')$ and $W_R - W = Tn$.

(A careful distinction should be made at this point between the expression $\int \frac{dH}{T}$ and the term *entropy*. The former is merely an expression for the latter under specific conditions. In the typical irreversible process furnished by the porous plug experiment, the entropy increased; and this is the case generally with such processes, in which $dn > \frac{dH}{T}$. Internal transfers of heat may augment the entropy even of a heat-insulated body, if it be not in uniform thermal condition. Perhaps the most general statement possible for the second law of thermodynamics is that *all actual processes tend to increase the entropy*; as we have seen, this keeps possible efficiencies below those of the perfect reversible engine. The product of the increase of entropy by the temperature is a measure of the waste of energy (3).)

Most operations in power machinery may without serious error be analyzed as if reversible; unrestricted expansions must always be excepted. The entropy diagram to this extent ceases to have "an automatic meaning."

(1) *The Temperature-Entropy Diagram*, 1908. (2) See Berry, *op. cit.* (3) The works of Preston, Swinburne, and Planck may be consulted by those interested in this aspect of the subject. See also the paper by M'Cadie, in the *Journal of Electricity, Power and Gas*, June 10, 1911, p. 505.

SYNOPSIS OF CHAPTER VIII

It is impracticable to measure PV heat areas between the adiabatics.

The rectangular diagram: *ordinates = temperature; areas = heat transfers.*

Application to a Carnot cycle: *a rectangle.*

The *validity of the diagram* is conditioned upon the absoluteness of the horizontal coördinate.

The *slope* of a path of constant specific heat depends upon the *value of the specific heat.*

The expression $\int \frac{dH}{T}$ has a definite value for any reversible change of condition, regardless of the path pursued to effect the change.

$dn = \frac{dH}{T}$, or $n = k \log_e \frac{T}{t}$ for *constant specific heat = k*, or $n = a \log_e \frac{T}{t} + b(T - t)$ for *variable specific heat = a + bT*.

The value of the specific heat along a polytropic is represented by the *length of the subtangent.*

Illustrations: comparison of k and l ; efficiency of Carnot cycle; the first law; the second law; heat area between adiabatics; Kelvin's absolute scale.

Entropy units are B. t. u. per degree absolute. The adiabatic for zero entropy is at

$$T = 32^\circ \text{ F.}, P = 2116.8.$$

$$n = k \log_e \frac{V}{V_a} + l \log_e \frac{P_b}{P_a} = l \log_e \frac{T_b}{T_a} + (k - l) \log_e \frac{V}{V_a} = k \log_e \frac{T_b}{T_a} + (k - l) \log_e \frac{P_a}{P_b}.$$

The mixing of substances at different temperatures increases the aggregate entropy.

Hydraulic analogy; physical significance of entropy; use of the diagram.

Derivation of the adiabatic equation.

Irreversible Processes

A reversible cycle is composed of reversible paths; example of an irreversible cycle.

Joule's experiment as an example of irreversible operation.

Heat generated by mechanical friction of particles; the path both isothermal and adiabatic, but not isentropic.

$$H = T + I + W + V \text{ or } V = -(I + T).$$

For irreversible processes, dn is *not* equal to $\frac{dH}{T}$; the subtended area does *not* represent a transfer of heat; non-isentropic adiabatics.

In reversible operations, the aggregate entropy of the participating substances is unchanged.

During irreversible operations, the aggregate entropy increases, and $\int \frac{dH}{T} < 0$.

The loss of work due to increase of entropy is nT ; $dn > \frac{dH}{T}$.

PROBLEMS

1. Plot to scale the TN path of one pound of air heated (a) at constant pressure from 100° F. to 200° F. , then (b) at constant volume to 300° F. The logarithmic curves may be treated as two straight lines.

2. Construct the entropy diagram for a Carnot cycle for one pound of air in which $T = 400^\circ \text{ F.}$, $t = 100^\circ \text{ F.}$, and the volume in the first stage increases from 1 to 4 cubic feet. Do not use the formulas in Art. 169.

3. Plot on the TN diagram paths along which the specific heats are respectively $0, \infty, 3.4, 0.23, 0.17, -0.3, -10.4$, between $T = 459.6$ and $T = 919.2$, treating the logarithmic curves as straight lines.

4. The variable specific heat being $0.20 - 0.0004 T - 0.000002 T^2$ (T being in Fahrenheit degrees), plot the TN path from 100° F. to 140° F. in four steps, using mean values for the specific heat in each step.

Find by integration the change of entropy during the whole operation.

5. What is the specific heat at $T = 40$ (absolute) for a path the equation of which on the TN diagram is $TN = c = 1200$? (*Ans.*, -32 .)

6. Confirm Art. 134 by computation from the TN diagram.

7. Plot the path along which 1 unit of entropy is gained per 100° absolute. What is the mean specific heat along this path from 0° to 400° absolute?

8. What is the entropy measured above the arbitrary zero per pound of air at normal atmospheric pressure in a room at 70° F. ? (*Ans.*, 0.01766 .)

9. Find the arbitrary entropy of a pound of air in the cylinder of a compressor at 2000 lb. pressure per square inch and 142° F. (*Ans.*, 0.301.)

10. Find the entropy of a sphere of hydrogen 10 miles in diameter at atmospheric pressure and 175° F. (*Ans.*, 289,900,000,000.)

11. The specific heat being $0.24 + 0.0002 T$, find the increase in entropy between 459.6 and 919.2 degrees, all absolute. What is the mean specific heat over this range? (*Ans.*, increase of entropy 0.25809; mean specific heat, 0.358.)

12. In a Carnot cycle between 500° and 100° , 200,000 ft. lb. of work are done. Find the amount of heat supplied and the variation in entropy during the cycle.

13. A Carnot engine works between 500° and 200° and between the entropies 1.2 and 1.45. Find the ft. lb. of work done per cycle.

14. To evaporate a pound of water at 212° F. and atmospheric pressure, 970.4 B. t. u. are required. If the specific volume of the water is 0.016 and that of the steam 26.8, find the changes in internal energy and entropy during vaporization.

15. Five pounds of air in a steel tank are cooled from 300° F. to 150° F. Find the amount of heat emitted and the change in entropy. (l for air = 0.1689.)

16. Compare the internal energy and the entropy per pound of air when (a) 50 cu. ft. at 90° F. are under a pressure of 100 lb. per sq. in., and (b) 5 cu. ft. at 100° F. are subjected to a pressure of 1200 lb. per sq. in.

17. Air expands from $p=100$, $v=4$ to $P=40$, $V=8$ (lb. per sq. in. and cu. ft. per lb.). Find the change in entropy, (a) by Eq. (A) Art. 169, (b) by the equation

$$n_2 - n_1 = s \log_e \frac{t_2}{t_1}, \text{ where } s = l \frac{n-y}{n-1}.$$

18. A mixture is made of 2 lb. of water at 100° , 4 lb. at 160° , and 6 lb. at 90° (all Fahr.). Find the aggregate entropies before and after mixture.

CHAPTER IX

COMPRESSED AIR (1)

177. Compressed Air Engines. Engines are sometimes used in which the working substance is cold air at high pressure. The pressure is previously produced by a separate device; the air is then transmitted to the engine, the latter being occasionally in the form of an ordinary steam engine. This type of motor is often used in mines, on locomotives, or elsewhere where excessive losses by condensation would follow the use of steam. For small powers, a simple form of rotary engine is sometimes employed, on account of its convenience, and in spite of its low efficiency. The absence of heat, leakage, danger, noise, and odor makes these motors popular in those cities where the public distribution of compressed air from central stations is practiced (1a). The exhausted air aids in ventilating the rooms in which it is used.

178. Other Uses of Compressed Air. Aside from the driving of engines, high-pressure air is used for a variety of purposes in mines, quarries, and manufacturing plants, for operating hoists, forging and bending machines, punches, etc., for cleaning buildings, for operating "steam" hammers, and for pumping water by the ingenious "air lift" system. In many works, the amount of power transmitted by this medium exceeds that conveyed by belt and shaft or electric wire. The air is usually compressed by steam power, and it is obvious that a loss must occur in the transformation. This loss may be offset by the convenience and ease of transmitting air as compared with steam; the economical generation, distribution, and utilization of this form of power have become matters of first importance.

The first applications were made during the building of the Mont Cenis tunnel through the Alps, about 1860 (2). Air was there employed for operating locomotives and rock drills, following Colladon's mathematical computation of the small loss of pressure during comparatively long transmissions. A general introduction in mining operations followed. Two-stage compressors with intercoolers were in use in this country as early as 1881. Among the projects submitted to the international commission for the utilization of the power of Niagara, there were three in which distribution by compressed air was contemplated. Widespread industrial applications of this medium have accompanied the perfecting of the small modern interchangeable "pneumatic tools."

179. Air Machines in General. In the type of machinery under consideration, a considerable elevation of pressure is attained. Centrifugal fans or paddle-wheel blowers, commonly employed in ventilating plants, move large volumes of air at very slight pressures,—usually a fraction of a pound,—and the thermodynamic

relations are unimportant. Rotary blowers are used for moderate pressures, — up to 20 lb., — but they are generally wasteful of power and are principally employed to furnish blast for foundry cupolas, forges, etc. The machine used for compressing air for power purposes is ordinarily a piston compressor, mechanically quite similar to a reciprocating steam engine. These compressors are sometimes employed for comparatively low pressures also, as “blowing engines.”

THE AIR ENGINE

180. Air Engine Cycle. In Fig. 57, *ABCD* represents an idealized air engine cycle. *AB* shows the admission of air to the cylinder. Since the latter is small as compared with the transmitting pipe line, the specific volume and pressure of the fluid, and consequently its temperature as well, remain unchanged.

BC represents expansion after the supply from the mains is cut off. If the temperature at *B* is that of the external atmosphere, and expansion proceeds slowly, so that any fall of temperature along *BC* is offset by the transmission of heat from the outside air through the cylinder walls, this line is an *isothermal*. If, however, expansion is rapid, so that no transfer of heat occurs, *BC* will be an *adiabatic*. In practice, the expansion line is a polytropic, lying usually between the adiabatic and the isothermal. *CD* represents the expulsion of the air from the cylinder at the completion of the working stroke. At *D*, the inlet valve opens and the pressure rises to that at *A*. The volumes shown on this diagram are not specific volumes, but *volumes of air in the cylinder*. Subtended areas, nevertheless, represent external work.

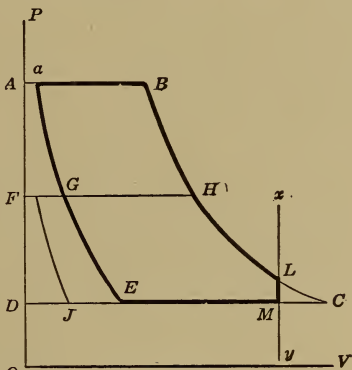

FIG. 57. Arts. 180–183, 189, 222, 223, 226, Prob. 6.—Air Engine Cycles.

CD represents the expulsion of the air from the cylinder at the completion of the working stroke. At *D*, the inlet valve opens and the pressure rises to that at *A*. The volumes shown on this diagram are not specific volumes, but *volumes of air in the cylinder*. Subtended areas, nevertheless, represent external work.

181. Modified Cycle. The additional work area *LMC* obtained by expansion beyond some limiting volume, say that along *xy*, is small. A slight gain in efficiency is thus made at the cost of a much larger cylinder. In practice, the cycle is usually terminated prior to complete expansion, and has the form *ABLMD*, the line *LM* representing the fall of pressure which occurs when the exhaust valve opens.

182. Work Done. Letting p denote the pressure along AB , P the pressure at the end of the expansion, q the "back pressure" along MD (slightly above that of the atmosphere), and letting v denote the volume at B , and V that at the end of expansion, both volumes being measured from OA as a line of zero volumes, then, for isothermal expansion, the work done is

$$pv + pv \log_e \frac{V}{v} - qV;$$

and for expansion such that $pv^n = PV^n$, it is

$$pv + \frac{pv - PV}{n-1} - qV.$$

(In these and other equations in the present chapter, the air will be regarded as free from moisture, a sufficiently accurate method of procedure for ordinary design. For air constants with moisture effects considered, see Art. 382*b*, etc.)

183. Maximum Work. Under the most favorable conditions, expansion would be isothermal and "complete"; *i.e.* continued down to the back-pressure line CD . Then, $q = P = pv \div V$, and the work would be $pv \log_e(V \div v)$. For *complete adiabatic* expansion, the work would be

$$pv + \frac{pv - PV}{y-1} - PV = (pv - PV) \left(\frac{y}{y-1} \right).$$

184. Entropy Diagram. This cannot be obtained by direct transfer from the PV diagram, because we are dealing with a varying quantity of air. The method of deriving an illustrative entropy diagram is explained in Art. 218.

185. Fall of Temperature. If air is received by an engine at P , T , and expanded to p , t , then from Art. 104, if $P \div p = 10$, and $T = 529^\circ$ absolute, with adiabatic expansion, $t = -187^\circ$ F.

This fall of temperature during adiabatic expansion is a serious matter. Low final temperatures are fatal to successful working if the slightest trace of moisture is present in the air, on account of the formation of ice in the exhaust valves and passages. This difficulty is counteracted in various ways: by circulating warm air about the exhaust passages; by specially designed exhaust ports; by a reduced range of pressures; by avoidance of adiabatic expansion (Art. 219); and by thoroughly drying the air. The jacketing of the cylinder with hot air has been proposed. Unwin mentions (3) the use of a spray of water, injected into the air while passing through a preheater (Art. 186). This reaches the engine as *steam* and condenses during expansion, giving up its latent heat of

vaporization and thus raising the temperature. In the experiments on the use of compressed air for street railway traction in New York, stored hot water was employed to preheat the air. The only commercially successful method of avoiding inconveniently low temperatures after expansion is by raising the temperature of the inlet air.

186. Preheaters. In the Paris installation (4), small heaters were placed at the various engines. These were double cylindrical boxes of cast iron, with an intervening space through which the air passed in a circuitous manner. The inner space contained a coke fire, from which the products of combustion passed over the top and down the outside of the outer shell. For a 10-hp. engine, the extreme dimensions of the heater were 21 in. in diameter and 33 in. in height.

187. Economy of Preheaters. The heat used to produce elevation of temperature is not wasted. The volume of the air is increased, and the *weight* consumed in the engine is correspondingly decreased. Kennedy estimated in one case that the reduction in air consumption due to the increase of volume should have been, theoretically, 0.30; actually, it was 0.25. The mechanical efficiency (Art. 214) of the engine is improved by the use of preheated air. In one instance, Kennedy computed a saving of 225 cu. ft. of "free" air (i.e. air at atmospheric pressure and temperature) to have been effected at an expenditure of 0.4 lb. of coke. Unwin found that all of the air used by a 72-hp. engine could be heated to 300° F. by 15 lb. of coke per hour. Figure 58 represents a modern form of preheater.

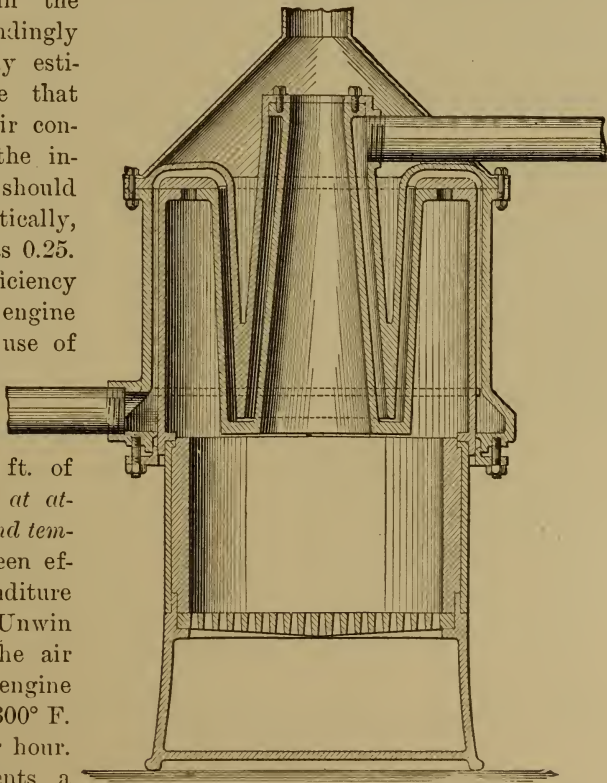

FIG. 58. Art. 187.—Rand Air Preheater.

188. Volume of Cylinder. If n be the number of single strokes per minute of a double-acting engine, V the cylinder volume (maximum volume of fluid), W the number of pounds of air used per minute, v the specific volume of the air at its lowest pressure p and its temperature t , N the horse power of the engine, and U the work done in foot-pounds per pound of air, then, ignoring *clearance* (the space between the piston and the cylinder head at the end of the stroke), the volume swept through by the piston per minute = $Wv = nV = WR \frac{t}{p}$; whence

$$V = \frac{WRt}{np}; \text{ and since } WU = 33,000N, W = \frac{33000N}{U}, \text{ and } V = \frac{33000NRt}{nUp}.$$

189. Compressive Cycle. For quiet running, as well as for other reasons, to be discussed later, it is desirable to arrange the valve movements so that some air is gradually compressed into the clearance space during the latter part of the return stroke, as along Ea , Fig. 57. This is accomplished by causing the exhaust valve to close at E , the inlet valve opening at a . The work expended in this compression is partially recovered during the subsequent forward stroke, the air in the clearance space acting as an elastic cushion.

190. Actual Design. A single-acting 10-hp. air engine at 100 r. p. m., working between 114.7 and 14.7 lb. absolute pressure, with an "apparent" (Art. 450) volume ratio during expansion of 5 : 1 and clearance equal to 5 per cent of the piston displacement, begins to compress when the return stroke of the piston is $\frac{9}{10}$ completed. The expansion and compression curves are $PV^{1.3} = c$. Assuming that the actual engine will give 90 per cent of the work theoretically computed, find the size of cylinder (diameter = stroke) and the free air consumption per Ihp.-hr.

In Fig. 59, draw the lines ab and cd representing the pressure limits. We are to construct the ideal PV diagram, making its enclosed length represent, to any convenient scale, the displacement of the piston per stroke. The extreme length of the diagram from the oP axis will be 5 per cent greater, on account of clearance. The limiting volume lines ef and gh are thus sketched in; BC is plotted, making $\frac{eg}{AB} = 5$; the point E is taken so that $\frac{ED}{Di} = 0.9$, and EF drawn. Then

$ABCDEF$ is the ideal diagram. We have, putting $Di = D$,

$$P_A = P_B = 114.7.$$

$$P_D = P_E = 14.7.$$

$$V_C = V_D = 1.05 D.$$

$$V_B = 0.25 D.$$

$$V_F = V_A = 0.05 D.$$

$$V_E = 0.15 D.$$

$$P_C V_C^n = P_B V_B^n \text{ or } P_C = P_B \left(\frac{V_B}{V_C} \right)^n = 114.7 \left(\frac{0.25}{1.05} \right)^{1.3} = 17.75.$$

$$P_F V_F^n = P_E V_E^n \text{ or } P_F = P_E \left(\frac{V_E}{V_F} \right)^n = 14.7 \left(\frac{0.15}{0.05} \right)^{1.3} = 61.31.$$

$$\begin{aligned} \text{Work per stroke} &= jABi + iBCm - EDmk - jFEk \\ &= P_A(V_B - V_A) + \frac{P_B V_B - P_C V_C}{n-1} - P_E(V_D - V_E) - \frac{P_F V_F - P_E V_E}{n-1} \\ &= 144 \left[(114.7 \times 0.20 D) + \frac{(114.7 \times 0.25 D) - (17.75 \times 1.05 D)}{0.3} \right. \\ &\quad \left. - (14.7 \times 0.9 D) - \frac{(61.31 \times 0.05 D) - (14.7 \times 0.15 D)}{0.3} \right] \\ &= 5803.2 D \text{ foot-pounds.} \end{aligned}$$

The actual engine will then give $0.9 \times 5803.2 D = 5222.88 D$ foot-pounds per stroke or $5222.88 D \times 100$ foot-pounds per minute, which is to be made equal to 10 hp., or

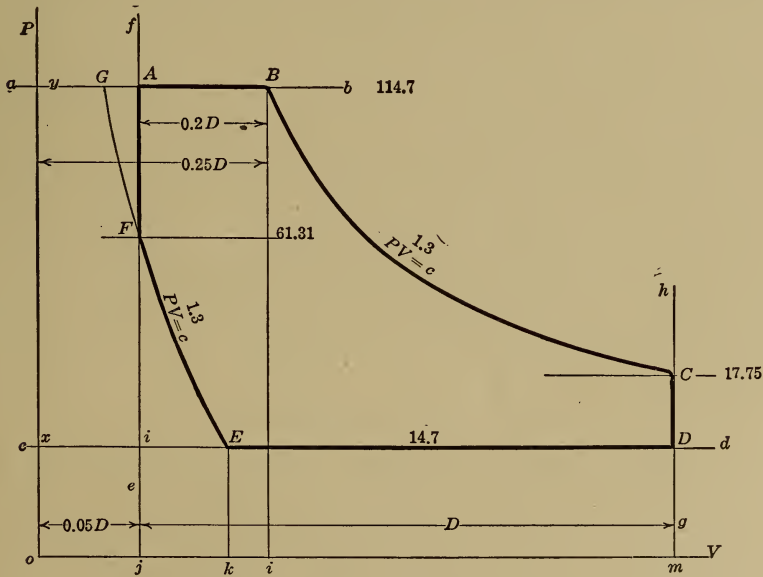

FIG. 59. Art. 190.—Design of Air Engine.

to $10 \times 33,000$ foot-pounds. Then $522,288 D = 330,000$ and $D = 0.63$ cu. ft. Since the diameter of the engine equals its stroke, we write $0.7854 d^2 \times d = 0.63 \times 1728$, where d is the diameter in inches; whence $d = 11.15$ in.

To estimate the air consumption: at the point B , the whole volume of air is $0.25 D$. Part of this is clearance air, used repeatedly, and not chargeable to the engine. The clearance air at E had the volume V_E and the pressure P_E . If its

behavior conforms to the law $PV^{1.3} = c$, then at the pressure of 114.7 lb. (point G) we would have

$$P_G V_G^n = P_E V_E^n \text{ or } V_G = V_E \left(\frac{P_E}{P_G} \right)^{\frac{1}{1.3}} = 0.15 D \left(\frac{14.7}{114.7} \right)^{0.769} = 0.0309 D.$$

The volume of *fresh* air brought into the cylinder per stroke is then

$$0.25 D - 0.0309 D = 0.2191 D$$

or, per hour, $0.2191 \times 0.63 \times 100 \times 60 = 828$ cu. ft. Reduced to *free* air (Art. 187), this would be $828 \times \frac{114.7}{14.7} = 6450$ cu. ft., or 645 cu. ft. per Ihp.-hr. (Compare Art. 192.)

191: Effect of Early Compression. If compression were to begin at a sufficiently early point, so that the pressure were raised to that in the supply pipe before the admission valve opened, the fresh air would find the clearance space already completely filled, and a less quantity of such fresh air, by $0.05 D$, instead of $0.0309 D$, would be required.

192. Actual Performances of Air Engines. Kennedy (5) found a consumption of 890 cu. ft. of free air per Ihp.-hr., in a small horizontal *steam* engine. Under the conditions of Art. 183, the *theoretical maximum* work which this quantity of air could perform is 1.27 hp. The cylinder efficiency (Art. 215) of the engine was therefore $1.0 \div 1.27 = 0.79$. With small rotary engines, without expansion, tests of the Paris compressed air system showed free air consumption rates of from 1946 to 2330 cu. ft. By working these motors expansively, the rates were brought within the range from 848 to 1286 cu. ft. A good reciprocating engine with preheated air realized a rate of 477 cu. ft., corresponding to 36.4 lb., per *brake* horse power per hour. The cylinder efficiencies in these examples varied from 0.368 to 0.876, and the mechanical efficiencies (Art. 214) from 0.85 to 0.92.

THE AIR COMPRESSOR

193. Action of Piston Compressor. Figure 60 represents the parts concerned in the cycle of an air compressor. Air is drawn from the atmosphere through the spring check valve a , filling the space C in the cylinder. This inflow of air continues until the piston has reached its extreme right-hand position. On the return stroke, the valve a being closed, compression proceeds until the pressure is slightly greater than that in the receiver D . The balanced outlet valve b then opens, and air passes from C to D at practically constant pressure. When the pis-

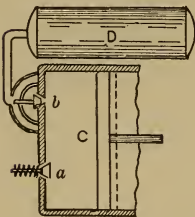

FIG. 60. • Art. 193.—Piston Compressor.

ton reaches the end of its stroke, there will still remain the clearance volume of air in the cylinder. This expands during the early part of the next stroke to the right, but as soon as the pressure of this air falls slightly below that of the atmosphere, the valve *a* again opens.

194. Cycle. An actual diagram is given, as *ADCB*, Fig. 61. Slight fluctuations in pressure occur, on account of fluttering through the valves, during discharge along *AD* and during suction along *CB*; the mean discharge pressure must of course be slightly greater than the receiver pressure, and the mean suction pressure slightly less than atmospheric pressure. Eliminating these irregularities and the effect of clearance, the ideal diagram is *a'cb'*.

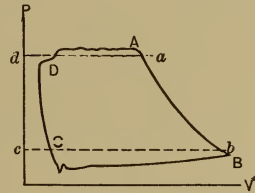

FIG. 61. Art. 194.—Cycle of Air Compressor.

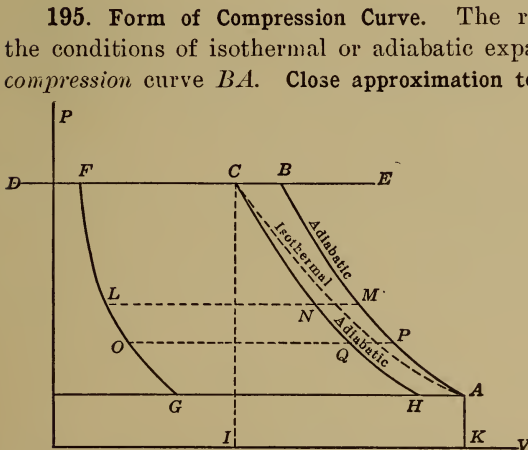

FIG. 62. Arts. 195, 197, 213, 218.—Forms of Compression Curve.

has been compressed, and to the same pressure, in either case; the area *ABC* represents, therefore, needlessly expended work. Furthermore, during transmission to the point at which the air is to be applied, in the great majority of cases, the air will have been cooled down practically to the temperature of the atmosphere; so that even if compressed adiabatically, with rise of temperature, to *B*, it will nevertheless be at the state *C* when ready for expansion in the consumer's engine. If it there

the conditions of isothermal or adiabatic expansion apply equally to the compression curve *BA*. Close approximation to the isothermal path is the ideal of compressor performance. Let *A*, Fig. 62, be the point at which compression begins, and let *DE* represent the maximum pressure to be attained. Let the cycle be completed through the states *F*, *G*. Then the work expended, if compression is isothermal, is *ACFG*; if adiabatic, the work expended is *ABFG*. The same amount of air

again *expand adiabatically* (along CH) instead of isothermally (along CA), a definite amount of available power will have been lost, represented by the area CHA . During compression, we aim to have the work area small; during expansion the object is that it be large; the adiabatic path prevents the attainment of either of these ideals.

The loss of power by adiabatic compression is so great that various methods are employed to produce an approximately isothermal path. As a general rule, the path is consequently intermediate between the isothermal and the adiabatic, a polytropic, $pv^n = C$. The relations derived in Arts. 183 and 185 for adiabatic expansion apply equally to this path, excepting that for y we must write n , the value of n being somewhere between 1.0 and 1.402. The effect of water in the cylinder, whether introduced as vapor with the air, or purposely injected, is to somewhat reduce the value of n , to increase the interchange of heat with the walls, and to cause the line FG , Fig. 62, to be straight and vertical, rather than an adiabatic expansion, thus slightly increasing the capacity of the compressor, as shown in Art. 222.

196. Temperature Rise. The rise of temperature due to compression may be computed as in Art. 185. Under ordinary conditions, the air leaves the compressor at a temperature higher than that of boiling water. Without cooling devices, it may leave at such a temperature as to make the pipes red hot. It is easy to compute the (not very extreme) conditions under which the rise in temperature would be sufficient to melt the cast-iron compressor cylinder.

197. Computation of Loss. The uselessly expended work during adiabatic (and similarly, during any other than isothermal) compression may be directly computed from the difference of the work areas $CAKI$ and $CBAKI$, Fig. 62. The work under the isothermal is $(p, v$, referring to the point C , and P, V , to the point A), $pv \log_e (V + v) = pv \log_e (p + P)$; while if Q is the volume at B , the work under ABC is

$$p(Q - v) + \frac{pQ - PV}{y - 1};$$

but

$$pQ^y = PV^y \text{ and } Q = V \left(\frac{P}{p} \right)^{\frac{1}{y}};$$

so that the percentage of loss corresponding to any ratio of initial and final pressures and any terminal (or initial) volume may be at once computed.

198. Basis of Methods for Improvement. Any value of n exceeding 1.0 for the path of compression is due to the generation of heat as the pressure rises, faster than the walls of the cylinder can transmit it to the atmosphere. The high temperatures thus produced introduce serious difficulties in lubrication. Economical compression is a matter of *air cooling*; while, on the consumer's part, economy depends upon *air heating*.

199. Air Cooling. In certain applications, where a strong draft is available, the movement of the atmosphere may be utilized to cool the compressor cylinder walls and thus to chill the working air during compression. While this method of cooling is quite inadequate, it has the advantage of simplicity and is largely employed on the air "pumps" which operate the brakes of railway trains.

200. Injection of Water. This was the method of cooling originally employed at Mont Cenis by Colladon. Figure 63 shows the actual indicator card from one of the older Colladon compressors. *EBCD* is the corresponding ideal card with isothermal compression. The cooling by stream injection was evidently not very effective. Figure 64 represents another diagram from a compressor in which this method of cooling was employed; *ab* representing the isothermal and *ac* the adiabatic. The exponent of the actual curve *ad* was 1.36; the gain over adiabatic compression was very slight. By

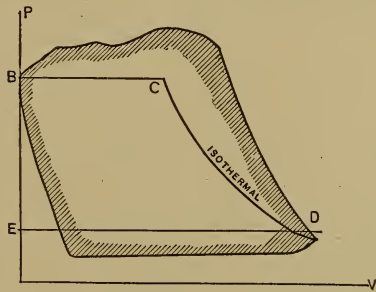

FIG. 63. Art. 200.—Card from Colladon Compressor.

introducing the water in a *very fine* spray, a somewhat lower value of the exponent was obtained in the compressors used by Colladon on the St. Gothard tunnel. Gause and Post (6) have reduced the value of *n* to 1.26 by an atomized spray. Figure 65 shows one of their diagrams, *ab* being the isothermal and *ac* the adiabatic. In all cases, spray injection is better than solid stream injection. The value *n* = 1.36, above given, was obtained when a solid jet of half-inch diameter was used. It is estimated that errors of the indicator may introduce an uncertainty amounting to 0.02 in the value of *n*. Piston leakage would cause an

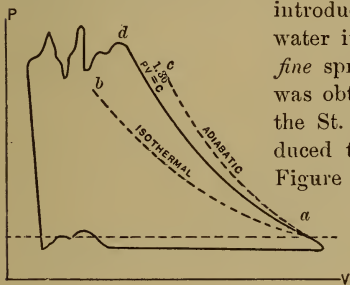

FIG. 64. Art. 200.—Cooling by Jet Injection.

apparently low value. The comparative efficiency of spray injection is shown from the fairly uniform temperature of discharged air, which can be maintained even with a varying speed of the compressor. In the Gause and Post experiments, with inlet air at $81\frac{1}{2}^{\circ}$ F., the temperature of discharge was 95° F. Spray injection has the objection that it fills the air with vapor, and it has been found that the orifices must be so small that they soon clog and become inoperative. The use of either a spray or a solid jet causes cutting of the cylinder and piston by the gritty substances carried in the water. In American practice the injection of water has been abandoned.

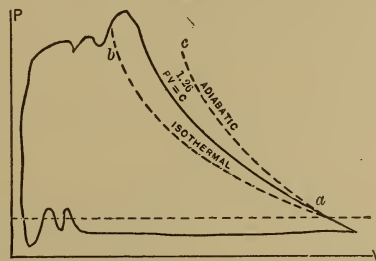

FIG. 65. Art. 200.—Cooling by Atomized Spray.

201. Water Jackets. These reduce the value of n to a very slight extent only, but are generally employed because of their favorable influence

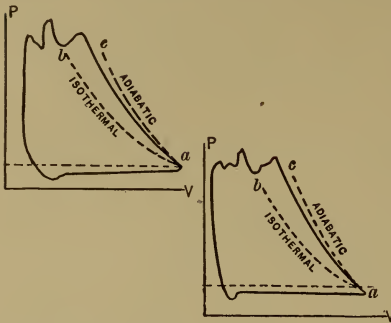

FIG. 66. Art. 201.—Cooling by Jackets.

on cylinder lubrication. Gause and Post found that with inlet air at 81° F., and jackets on the barrels of the cylinders only (not on the heads), the temperature of the discharged air was 320° F. Cooling occurred during expulsion rather than during compression. The cooling effect depends largely upon the heat transmissive power of the cylinder walls, and the value of n consequently increases at high speeds. Two specimen cards

are given in Fig. 66; ab being the isothermal and ac the adiabatic. With the more thorough cooling, jacketed heads, etc., a lower value of n may be obtained; but this value is seldom or never below 1.3. Figure 67 shows a card given by Unwin from a Cockerill compressor, DC indicating the ideal isothermal curve. At the higher pressures, air is apparently more readily cooled; its own heat-conducting power is increased.

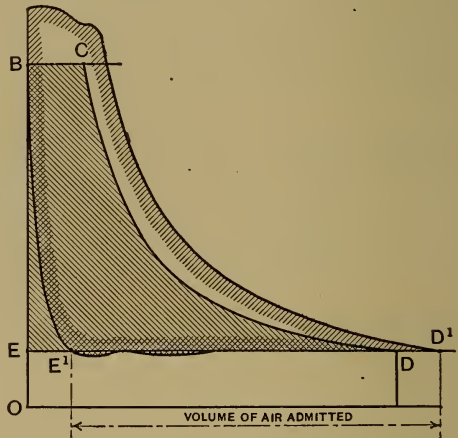

FIG. 67. Art. 201.—Cockerill Compressor with Jacket Cooling.

202. Heat Abstracted. In Fig. 68, let AB and AC be the adiabatic and the actual paths, AN and CN adiabatics; the heat to be abstracted is then equivalent to

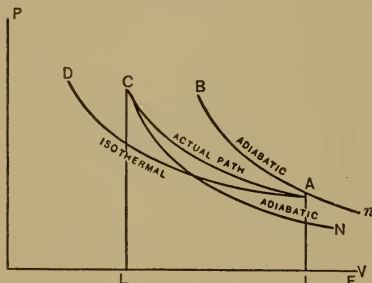

FIG. 68. Arts. 202, 203.—Heat Abstracted by Cooling Agent.

to be abstracted is then equivalent to

$$NCA_n = IACL + nAIE - NCLE.$$

$$\text{Now } IACL = \frac{pv - PV}{n - 1}, \quad nAIE = \frac{PV}{y - 1},$$

$$NCLE = \frac{pv}{y - 1};$$

whence

$$NCA_n = \frac{pv - PV}{n - 1} + \frac{PV}{y - 1} - \frac{pv}{y - 1}.$$

This is the heat to be abstracted per volume V at pressure P , compressed to

p , expressed in foot-pounds. For isothermal compression, as along AD , $IACL = pv \log_e (V \div v)$, and the total heat to be abstracted is measured by this area. If the path is adiabatic, AB , $n = \gamma$, and the expression for heat abstraction becomes zero.*

203. Elimination of v . It is convenient to express the total area NCA_n in terms of p , P , and V only. The area

$$IACL = \frac{pv - PV}{n - 1} = \frac{1}{n - 1} (pv - PV) = \frac{PV}{n - 1} \left(\frac{pv}{PV} - 1 \right) = \frac{PV}{n - 1} \left[\left(\frac{p}{P} \right)^{\frac{n-1}{n}} - 1 \right].$$

Also,

$$NCLE = \frac{pv}{y - 1} = \frac{pV}{y - 1} \left(\frac{p}{P} \right)^{\frac{1}{n}};$$

whence $NCA_n = \frac{PV}{n - 1} \left[\left(\frac{p}{P} \right)^{\frac{n-1}{n}} - 1 \right] + \frac{pV}{y - 1} - \frac{pV}{y - 1} \left(\frac{p}{P} \right)^{\frac{1}{n}}$.

204. Water Required. Let the heat to be abstracted, as above computed, be H , in heat units. Then if S and s are the final and initial temperatures of cooling water, and C the weight of water circulated, we have $C = H \div (S - s)$, the specific heat of water being taken as 1.0. In practice, the range of temperature of the cooling water may be from 40° to 70° F.

205. Multi-stage Compression. The *effective method* of securing a low value of n is by *multi-stage operation*, the principle of which is illustrated in Fig. 69. Let A be the state at the beginning of compression, and let it be assumed that the path is practically adiabatic, in spite of jacket cooling, as AB . Let AC be an isothermal. In multi-stage compression, the air follows the path AB up to a moderate pressure, as at D , and is then discharged and cooled at constant pressure in an *external vessel*, until its temperature is as nearly as possible that at which it was admitted to the cylinder. The path representing this cooling is DE . The air now passes to

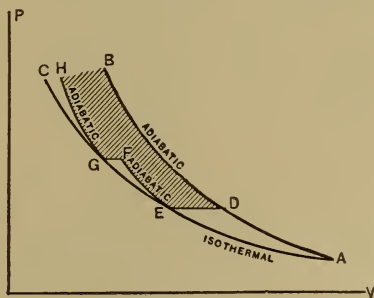

FIG. 69. Art. 205. — Multi-stage Compression.

* More simply, as suggested by Chevalier, the specific heat along AC is $s = l \frac{n - \gamma}{n - 1}$ (Art. 112); the heat to be abstracted is then

$$s(T - t) = \frac{l(n - \gamma)}{R(n - 1)} (PV - pv).$$

Both working air and cushion air must be cooled.

a second cylinder, is adiabatically compressed along *EF*, ejected and cooled along *FG*, and finally compressed in still another cylinder

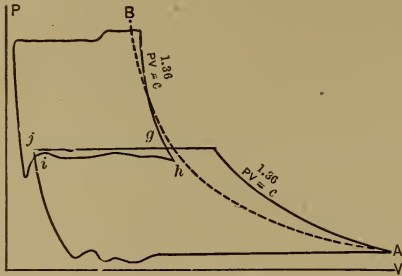

FIG. 70. Arts. 205, 206.—Two-stage Compressor Indicator Diagram.

along *GH*. The diagram illustrates compression in three “stages”; but two or four stages are sometimes used. The work saved over that of single stage adiabatic compression is shown by the irregular shaded area *HGFEDB*, equivalent to a reduction in the value of *n*, under good conditions, from 1.402 to about 1.25. Figure 70 shows the diagram from a two-stage 2000 hp. compressor, in which solid water jets were used in the cylinders. The cooling water was at a lower temperature than the inlet air, causing the point *h* to fall inside the isothermal curve *AB*. The compression curves in each cylinder give $n = 1.36$. Figure 71 is the diagram for a two-stage Riedler compressor with spray injection, *AB* being an isothermal and *AC* an adiabatic.

along *GH*. The diagram illustrates compression in three “stages”; but two or four stages are sometimes used. The work saved over that of single stage adiabatic compression is shown by the irregular shaded area *HGFEDB*, equivalent to a reduction in the value of *n*, under good conditions, from 1.402 to about 1.25. Figure 70 shows the diagram from a two-stage 2000 hp. compressor, in which solid water jets were used in the cylinders. The cooling water was at a lower temperature than the inlet air, causing the point *h* to fall inside the isothermal curve *AB*. The compression curves in each cylinder give $n = 1.36$. Figure 71 is the diagram for a two-stage Riedler compressor with spray injection, *AB* being an isothermal and *AC* an adiabatic.

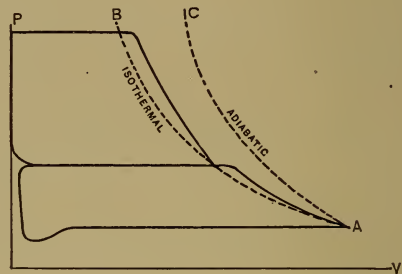

FIG. 71. Arts. 205, 214.—Two-stage Riedler Compressor Diagram.

206. Intercooling. Some work is always wasted on account of the friction of the air passing through the intercooling device. In early compressors, this loss often more than outweighed the gain due to compounding. The area *ghij*, Fig. 70, indicates the work wasted from this cause. In this particular instance, the loss is exceptionally small. Besides this, the additional air friction through two or more sets of valves and ports, and the extra mechanical friction due to a multiplication of cylinders and reciprocating parts must be considered. **Multi-stage compression does not pay unless the intercooling is thoroughly effective.** It seldom pays when the pressure attained is low. Incidental advantages in multi-stage operation arise from reduced mechanical stresses (Art. 462), higher volumetric efficiency (Art. 226), better lubrication, and the removal of moisture by precipitation during the intercooling.

207. Types of Intercoolers. The “external vessel” of Art. 205 is called the **intercooler**. It consists usually of a riveted or cast-iron cylindrical shell, with cast-

iron heads. Inside are straight tubes of brass or wrought iron, running between steel tube sheets. The back tube sheet is often attached to a stiff cast-iron inter-

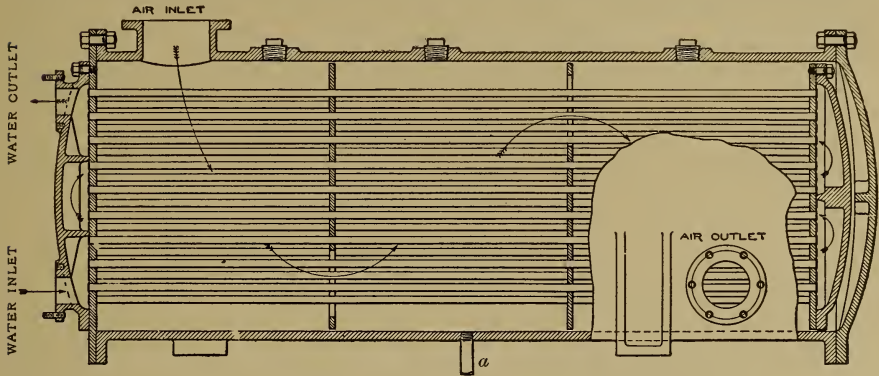

FIG. 72. Art. 207. — Allis-Chalmers Horizontal Intercooler.

nal head, so that the tubes, sheet, and head are free to move as the tubes expand (Fig. 72). The air entering the shell surrounds the tubes and is compelled by baffles to cross the tube space on its way to the outlet. Any moisture precipitated is drained off at the pipe *a*. The water is guided to the tubes by internally projecting ribs on the heads, which cause it to circulate from end to end of the intercooler, several times. If of ample volume, as it should be, the intercooler serves as a receiver or storage tank. The one illustrated is mounted in a horizontal position. A vertical type is shown in Fig. 73. The funnel provides a method of ascertaining at all times whether water is flowing.

208. Aftercoolers. In most manufacturing plants, the presence of moisture in the air is objectionable, on account of the difficulty of lubrication of air tools, and because of the rapid destruction of the rubber hose used for connecting these tools with the pipe line. To remove the moisture (and some of the oil) present after the last stage of com-

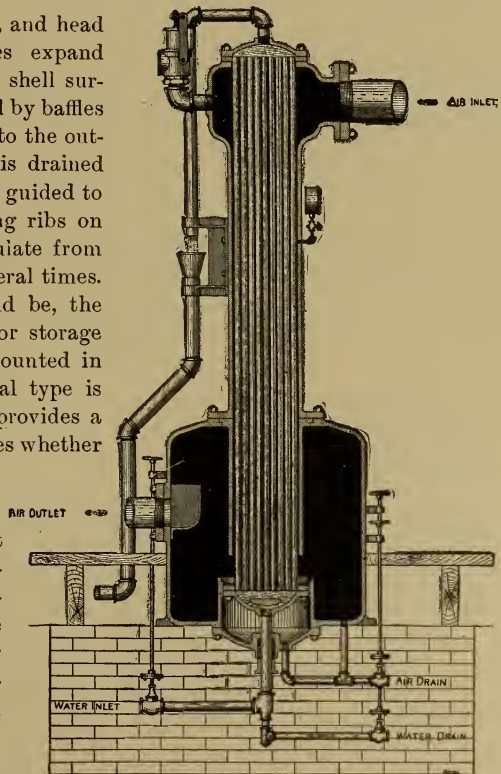

FIG. 73. Art. 207. — Ingersoll-Sergeant Vertical Intercooler.

pression, and by cooling the air to decrease the necessary size of transmitting pipe, **aftercoolers** are employed. They are similar in design and appearance to intercoolers. The cooling of the air decreases its capacity for holding water vapor, and the latter is accordingly precipitated where it may be removed before the air has reached its point of utilization. An incidental advantage arising from the use of an aftercooler is the decreased expansive stress on the pipe line following the introduction of air at a more nearly normal temperature.

209. Power Consumed. From Art. 98, the work under any curve $pv^n = PV^n$ is, adopting the notation of Art. 202, $\frac{pv - PV}{n-1}$,

$$= \frac{pv}{n-1} \left(1 - \frac{PV}{pv} \right) = \frac{pv}{n-1} \left\{ 1 - \left(\frac{P}{p} \right)^{\frac{n-1}{n}} \right\}.$$

The work along an adiabatic is expressed by the last formula if we make $n = \gamma = 1.402$. The work of expelling the air from the cylinder after compression is pv . The work of drawing the air into the cylinder, neglecting clearance, is $PV = pv \left(\frac{P}{p} \right)^{\frac{n-1}{n}}$. The net work expended in the cycle is the algebraic sum of these three quantities, which we may write,

$$\frac{pv}{n-1} \left\{ 1 - \left(\frac{P}{p} \right)^{\frac{n-1}{n}} \right\} + pv - pv \left(\frac{P}{p} \right)^{\frac{n-1}{n}} = \frac{pv}{n-1} \left\{ 1 - \left(\frac{P}{p} \right)^{\frac{n-1}{n}} \right\}.$$

It is usually more convenient to eliminate v , the volume after compression. This gives the work expression,

$$\frac{PVn}{n-1} \left\{ \left(\frac{p}{P} \right)^{\frac{n-1}{n}} - 1 \right\}.$$

If pressures are in pounds per square inch, the foot-pounds of work per minute will be obtained by multiplying this expression by the number of working strokes per minute and by 144; and the theoretical horse power necessary for compression may be found by dividing this product by 33,000. If we make $V=1$, $P=14.7$, we obtain the power necessary to compress *one cubic foot of free air*. If the air is to be used to drive a motor, it will then in most cases have cooled to its initial temperature (Art. 195), so that its volume after compression and cooling will be $PV \div p$. The work expended per cubic foot of this compressed and cooled air is then obtained by multiplying the work per cubic foot of *free* air by $\frac{p}{P}$.

210. Work of Compression. In some text-books, the work area under the compression curve is specifically referred to as the **work of compression**. This is not the total work area of the cycle.

211. Range of Stages in Multi-stage Compression. Let the lowest pressure be q , the highest p , and the pressure during intercooling P . Also let intercooling be complete, so that the air is reduced to its initial temperature, so that the volume V after intercooling is $\frac{qr}{P}$, in which r is the volume at the beginning of compression in the first cylinder. Adopting the second of the work expressions just found, and writing z for $\frac{n-1}{n}$, we have

$$\text{Work in first stage} = \frac{qr}{z} \left\{ \left(\frac{P}{q} \right)^z - 1 \right\}.$$

$$\text{Work in second stage} = \frac{PV}{z} \left\{ \left(\frac{p}{P} \right)^z - 1 \right\} = \frac{qr}{z} \left\{ \left(\frac{p}{P} \right)^z - 1 \right\}.$$

$$\text{Total work} = \frac{qr}{z} \left\{ \left(\frac{P}{q} \right)^z + \left(\frac{p}{P} \right)^z - 2 \right\} = W.$$

Differentiating with respect to P , we obtain

$$\begin{aligned} \frac{dW}{dP} &= \frac{qr}{z} \left[z \left(\frac{P}{q} \right)^{z-1} \frac{q}{q^2} - z \left(\frac{p}{P} \right)^{z-1} \frac{p}{P^2} \right] \\ &= qr \left\{ \frac{1}{q} \left(\frac{P}{q} \right)^{z-1} - \frac{p}{P^2} \left(\frac{p}{P} \right)^{z-1} \right\} \\ &= qr \left\{ \frac{P^{z-1}}{q^z} - \frac{p^z}{P^{z+1}} \right\}. \end{aligned}$$

For a *minimum value of W* , the result desired in proportioning the pressure ranges, this expression is put equal to zero, giving

$$P^2 = pq, \text{ or } P = \sqrt{pq}, \text{ or } \frac{T}{t} = \frac{T_q}{T}.$$

An extension of the analysis serves to establish a division of pressures for four-stage machines. From the pressure ranges given, it may easily be shown that in the ideal cycle **the condition of minimum work is that the amounts of work done in each of the cylinders be equal.** The number of stages increases as the range of pressures increases; in ordinary practice, the two-stage compressor is employed, with final pressures of about 100 lb. per square inch above the pressure of the atmosphere. In low-pressure blowing engines, the loss due to a high exponent for the compression curve is relatively less and these machines are frequently single stage.

For three-stage machines, working between the pressures p_1 (low) and p_2 (high), with receiver pressures of P_1 (low) and P_2 (high), the conditions of minimum work are $P_2 = \sqrt[3]{p_1 p_2^2}$ and $P_1 = \sqrt[3]{p_2 p_1^2}$, the amounts of work done in the three cylinders will be equal, and the cylinder volumes will be inversely as the suction pressures.

ENGINE AND COMPRESSOR RELATIONS

212. Losses in Compressed Air Systems. Starting with mechanical power delivered to the compressor, we have the following losses:

- (a) friction of the compressor mechanism, affecting the *mechanical efficiency*;
- (b) thermodynamic loss, chiefly from failure to realize isothermal compression, but also from friction and leakage of air, clearance, etc., indicated by the *cylinder efficiency*;
- (c) transmissive losses in pipe lines;
- (d) thermodynamic losses at the consumer's engine, like those of (b);
- (e) friction losses at the consumer's engine, like those of (a).

213. Compressive Efficiency. While not an efficiency in the true sense of the term, the relation of work generated during expansion in the engine to that expended during compression in the compressor is sometimes called the **compressive efficiency**. It is the quotient of the areas $FCHG$ and $FBAG$, Fig. 62. From the expression in Art. 209 for work under a polytropic plus work of discharge along BF or of admission along FC , we note that, the values of P and p being identical for the two paths, AB and CH , in question, the total work under either of these paths is a direct function of the volume V at the lower pressure P . In this case, providing the value of n be the same for both paths, the two work areas have the ratio $V \div x$, where V is the volume at A , and x that at H . It follows that all the ratios of volumes $LN \div LM$, $OQ \div OP$, etc., are equal, and equal to the ratio of areas. The compressive efficiency, then, $= \frac{x}{V} = T \div t$, where t is the temperature at A (or that at C), and T that at H . For isothermal paths, $T = t$, and the compressive efficiency is unity. In various tests, the compressive efficiency has ranged from 0.488 to 0.898. It depends, of course, on the value of n , increasing as n decreases.

214. Mechanical Efficiency. For the compressor, this is the quotient of work expended in the cylinder by work consumed at the fly wheel; for the engine, it is the quotient of work delivered at the fly wheel by work done in the cylinder.

Friction losses in the mechanism measure the mechanical inefficiency of the compressor or engine. With no friction, all of the power delivered would be expended in compression, and all of the elastic force of the air would be available for doing work, and the mechanical efficiency would be 1.0. In practice, since compressors are usually directly driven from steam engines, with piston rods in common, it is impossible to distinguish between the mechanical efficiency of the compressor and that of the steam engine. The *combined* efficiency, in one of the best recorded tests, is given as 0.92. For the compressor whose card is shown in Fig. 71, the combined efficiency was 0.87. Kennedy reports an average figure of 0.845 (7). Unwin states that the usual value is from 0.85 to 0.87 (8). These efficiencies are of course determined by comparing the areas of the steam and air indicator cards.

215. Cylinder Efficiency. The true efficiency, thermodynamically speaking, is indicated by the ratio of areas of the actual and ideal PV diagrams. For the

compressor, the cylinder efficiency is the ratio of the work done in the ideal cycle, without clearance, drawing in air at atmospheric pressure, compressing it isothermally and discharging it at the constant receiver pressure, to the work done in the actual cycle of the same maximum volume. It measures item (b) (Art. 212). It is not the "compressive efficiency" of Art. 213. For the engine, it is the ratio of the work done in the actual cycle to the work of an ideal cycle without clearance, with isothermal expansion to the same maximum volume from the same initial volume, and with constant pressures during reception and discharge; the former being that of the pipe line and the latter that of the atmosphere. Its value may range from 0.70 to 0.90 in good machines, in general increasing as the value of n decreases. An additional influence is fluid friction, causing, in the compressor, a fall of pressure through the suction stroke and a rise of pressure during the expulsion stroke; and in the engine, a fall of pressure during admission and excessive back pressure during exhaust. All of these conditions alter the area of the PV cycle. In well-designed machines, these losses should be small. A large capacity loss in the cylinder is still to be considered.

216. Discussion of Efficiencies. Considering the various items of loss suggested in Art. 212, we find as average values under good conditions,

- (a) mechanical efficiency, 0.85 to 0.90; say 0.85;
- (b) cylinder efficiency of compressor, 0.70 to 0.90; say 0.80;
- (c) transmission losses, as yet undetermined;
- (d) cylinder efficiency of air engine, 0.70 to 0.90; say 0.70;
- (e) mechanical efficiency of engine, 0.80 to 0.90; say 0.80.

The combined efficiency from steam cylinder to work performed at the consumer's engine, assuming no loss by transmission, would then be, as an average,

$$0.85 \times 0.80 \times 0.70 \times 0.80 = 0.3808.$$

For the Paris transmission system, Kennedy found the over-all efficiency (including pipe line losses, 4 per cent) to be 0.26 with cold air or 0.384 with preheated air, allowing for the fuel consumption in the preheaters (9).

217. Maximum Efficiency. In the processes described, the ideal efficiency in each case is unity. We are here dealing not with thermodynamic transformations between heat and mechanical energy, but only with transformations from one form of mechanical energy to another, in part influenced by heat agencies. No strictly thermodynamic transformation can have an efficiency of unity, on account of the limitation of the second law.

218. Entropy Diagram. Figure 62 may serve to represent the combined ideal PV diagrams of the compressor ($GABF$) and engine ($FCHG$).

The quotient $\frac{FCHG}{GABF}$ is the compressive efficiency. The area representing net expenditure of work, that is, waste, is $CBAH$, bounded ideally by two

adiabatics or in practice by two polytropics (not ordinarily isodiabatics) and two paths of constant pressure. This area is now to be illustrated on the TN coördinates.

For convenience, we reproduce the essential features of Fig. 62 in Fig. 74. In Fig. 75, lay off the isothermal T , and choose the

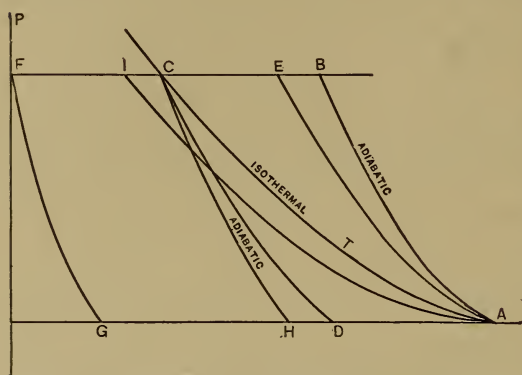

FIG. 74. Art. 218.—Engine and Compressor Diagrams.

point A at random. Now if either T_B or T_H be given, we may complete the diagram. Assume that the former is given; then plot the corresponding isothermal in Fig. 75. Draw AB , an adiabatic, BC and AH as lines of constant pressure

($n = k \log_e \frac{T}{t}$), the point C falling on the isothermal T . Then draw CH , an adiabatic, de

termining the point H ; or, from Art. 213, noting that $\frac{T_B}{T_C} = \frac{T_A}{T_H}$, we

may find the point H directly. If the paths AB and CH are not adiabatics, we may compute the value of the specific heat from that of n and plot these paths on Fig. 75 as logarithmic curves; but if the values of n are different for the two paths, it no longer holds

that $\frac{T_B}{T_C} = \frac{T_A}{T_H}$. The area

$CBAH$ in Fig. 75 now represents the net work expenditure in heat units.

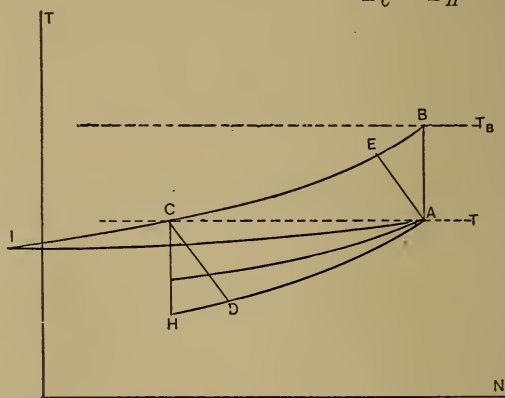

FIG. 75. Arts. 218, 219, 221.—Compressed Air System, Entropy Diagram.

219. Comments. As the exponents of the paths AB and CH decrease, these paths swerve into new positions, as AE , CD , decreasing the area representing work expenditure. Finally, with $n = 1$, isothermal paths, the area of the diagram becomes zero; a straight line, CA . Theoretically,

with water colder than the air, it might be possible to *reduce the temperature of the air during compression*, giving such a cycle as *AICDA*, or even, with isothermal expansion in the engine, *AICA*; in either case, the net work expenditure might be *negative*; the cooling water accomplishing the result desired.

220. Actual Conditions. Under the more usual condition that the temperature of the air at admission to the engine is somewhat higher than that at which it is received by the compressor, we obtain Figs. 76, 77. T , T_C and either T_B or T_H must now be given. The cycle in which the temperature is reduced during compression now appears as *AICDA* or *AIJA*.

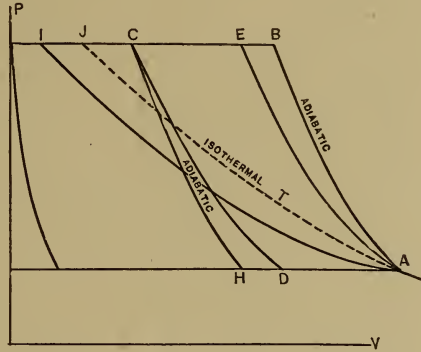

FIG. 76. Art. 220.—Usual Combination of Diagrams.

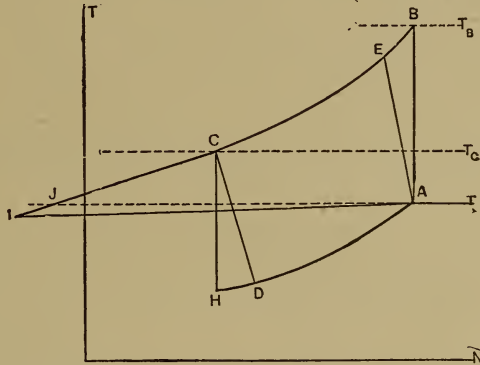

FIG. 77. Art. 220.—Combined Entropy Diagrams.

221. Multi-stage Operation. Let the ideal *pv* path be *DECBA*, Fig. 78. The “triangle” *ABC* of Fig. 75 is then replaced by the area *DECBA*, Fig. 79, bounded by lines of constant pressure and adiabatics. The area

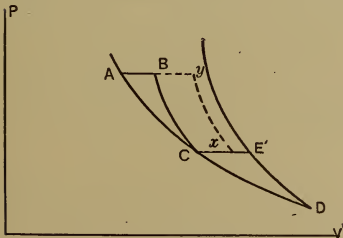

FIG. 78. Art. 221.—Three-stage Compression and Expansion.

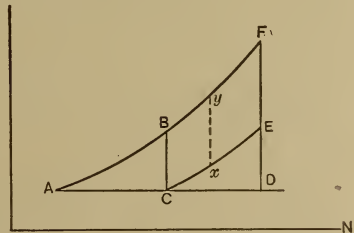

FIG. 79. Art. 221.—Entropy Diagram, Multi-stage Compression.

saved is $BFEC$, which approaches zero as the pressure along CE , Fig. 78, approaches that along AB or at D , and becomes a maximum at an intermediate position, already determined in Art. 211.

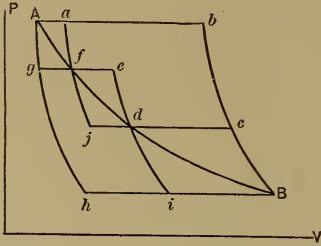

FIG. 80. Art. 221. — Three-stage Compression and Expansion.

With inadequate intercooling, the area representing work saved would be $yFEa$. Figures 80 and 81 represent the ideal pv and nt diagrams respectively for compressor and engine, each three-stage, with perfect intercooling and aftercooling and preheating and with no drop of pressure in transmission. BbA and AhB would be the diagrams with single-stage adiabatic compression and expansion.

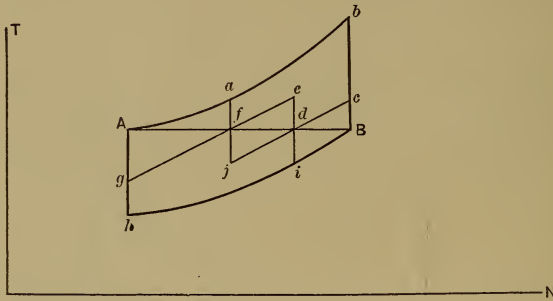

FIG. 81. Art. 221. — Three-stage Compression and Expansion.

COMPRESSOR CAPACITY

222. Effect of Clearance on Capacity. Let $ABCD$, Fig. 57, be the ideal pv diagram of a compressor without clearance. If there is clearance, the diagram will be $aBCE$; the air left in the cylinder at a will expand, nearly adiabatically, along aE , so that its volume at the intake pressure will be somewhat like DE . The total volume of fresh air taken into the cylinder cannot be DC as if there were no clearance, but is only EC . The ratio EC ($V_C - V_a$) is called the **volumetric efficiency**. It is the ratio of free air drawn in to piston displacement.

223. Volumetric Efficiency. This term is sometimes incorrectly applied to the factor $1 - c$, in which c is the clearance, expressed as a fraction of the cylinder volume. This is illogical, because this fraction measures the ratio of clearance air at final pressure, to inlet air at atmospheric pressure ($Aa \div DC$, Fig. 57); while the reduction of compressor capacity is determined by the volume of clearance air at atmospheric pressure. *If the clearance is 3 per cent, the volumetric efficiency is much less than 97 per cent.*

224. Friction and Compressor Capacity. If the intake ports or pipes are small, an excessive suction will be necessary to draw in the charge, and the cylinder will

be filled with air at less than atmospheric pressure. Its equivalent volume at atmospheric pressure will then be less than that of the cylinder. This is shown in Fig. 82. The line of atmospheric pressure is DF , the capacity is reduced by FG , and the volumetric efficiency is $DF \div HG$. The capacity may be seriously affected from this cause, in the case of a badly designed machine.

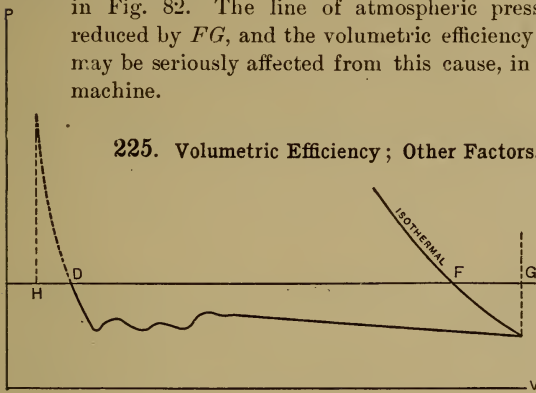

Fig. 82. Art. 224. — Effect of Suction Friction.

225. Volumetric Efficiency; Other Factors.

Where jackets or water jets are used, the air is often somewhat heated during the intake stroke, increasing its volume, and thus, as in Art. 224, lowering the volumetric efficiency. The effect is more noticeable with jacket cooling, with which the cylinder walls often remain constantly at a temperature above that of boiling water. Tests have shown a loss of capacity of 5 per cent, due to changing from spray injection to jacketing. — A high altitude for the compressor results in its being supplied with rarefied air, and this decreases the volumetric efficiency as based on air under standard pressure. At an elevation of 10,000 ft. the capacity falls off 30 per cent. (See table, Art. 52a.) This is sometimes a matter of importance in mining applications also. — Volumetric efficiency, in good designs, is principally a matter of low clearance. The clearance of a cylinder is practically constant, regardless of its length; so that its percentage is less in the case of the longer stroke compressors. Such compressors are comparatively expensive. — When water is injected into the cylinder, as is often the case in European practice, the clearance space may be practically filled with water at the end of the discharge stroke. Water does not appreciably expand as the pressure is lowered; so that in these cases the volumetric efficiency may be determined by the expression $1 - c$ of Art. 223, being much greater than in cases where water injection is not practiced.

226. Volumetric Efficiency in Multi-stage Compression. Since the effect of multi-stage compression is to reduce the pressure range, the expansion of the air caught in the clearance space is less, and the distance DE , Fig. 57, is reduced. This makes the volumetric efficiency, $EC \div (V_c - V_a)$, greater than in single-stage cylinders. If FGH represent the line of intermediate pressure, the ratio $JE \div (V_c - V_a)$ is the gain in volumetric efficiency.

227. Refrigeration of Entering Air. Many of the advantages following multi-stage operation and intercooling have been otherwise successfully realized by the plan of cooling the air drawn into the compressor. This of course increases the density of the air at atmospheric pressure, and greatly increases the volumetric efficiency. Incidentally, much of the moisture is precipitated. At the Isabella furnace of the Carnegie Steel Company, at Etna, Pennsylvania, a plant of this

kind has been installed. An ordinary ammonia refrigerating machine cools the air from 80° to 28° F. This should decrease the specific volume in the ratio $(459.6 + 28) \div (459.6 + 80) = 0.90$. The free air capacity should consequently be increased in about this ratio (10).

228. Typical Values. Excluding the effect of clearance, a loss in capacity of from 6 to 22 per cent has been found by Unwin (11) to be due to air friction losses and to heating of the entering air. Heilemann (12) finds volumetric efficiencies from 0.73 to 0.919. The volumetric efficiency could be *precisely* determined only by measuring the air drawn in and discharged.

229. Volumetric and Thermodynamic Efficiencies. The volumetric efficiency is a measure of the *capacity* only. It is not an efficiency in the sense of a ratio of "effect" to "cause." In Fig. 83 the solid lines show an actual compressor diagram, the dotted lines, *EGHB*, the corresponding perfect diagram, with clearance and isothermal compression. In the actual case we have the wasted work areas,

HLJQ, due to friction in discharge ports;

GQKD, due to non-isothermal compression;

DFMC, due to friction during the suction of the air.

At *BHC*, there is an area representing, apparently, a saving in work expenditure, due to the *expansion of the clearance air*; this saving in work has been accomplished, however,

with a decreased capacity in the proportion $BC \div BE$, a proportion which is greater than that of *BHC* to the total work area. Further, expansion of the clearance air is made possible as a result of its previous compression along *FDK*; and the energy given up by expansion can never quite equal that expended in compression. The effect of *excessive friction during suction*, reducing the capacity in the ratio $DE \div BE$, is

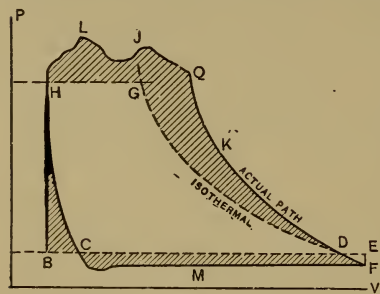

FIG. 83. Art. 229.—Volumetric and Thermodynamic Efficiencies.

usually more marked on the capacity than on the work. Both suction friction and clearance decrease the cylinder efficiency as well as the volumetric efficiency, but the former cannot be expressed in terms of the latter. In fact, a low volumetric efficiency may decrease the work expenditure absolutely, though not relatively. An instance of this is found in the case of a compressor working at high altitude. *Friction during discharge* decreases the cylinder efficiency (note the wasted work area *HLJQ*), but is practically without effect on the capacity.

COMPRESSOR DESIGN

230. Capacity. The necessary size of cylinder is calculated much as in Art. 190. Let p, v, t , be the pressure, volume, and temperature of discharged air (v meaning the volume of air handled **per minute**), and P, V, T , those of the inlet air. Then, since $PV \div T = pv \div t$, the volume drawn into the compressor per minute is $V = pvT \div Pt$, provided that the air is dry at both intake and delivery. If n is the number of revolutions per minute, and the compressor is double-acting, then, neglecting clearance, the piston displacement per stroke is $V \div 2n = \frac{pvT}{2nPt}$.

This computation of capacity takes no account of volumetric losses. In some cases, a rough approximation is made, as described, and by slightly varying the speed of the compressor its capacity is made equal to that required. Allowance for clearance may readily be made. Let the suction pressure be P , the final pressure p , the clearance volume at the final pressure $\frac{1}{m}$ of the piston displacement. Then, if expansion in the clearance space follows the law $pv^n = PV^n$, the volume of clearance air at atmospheric pressure is

$$\left(\frac{1}{m}\right)\left(\frac{p}{P}\right)^{\frac{1}{n}}$$

of the piston displacement. For the displacement above given, we therefore write,

$$\frac{V}{2n} \div \left[1 + \frac{1}{m} - \left(\frac{1}{m}\right)\left(\frac{p}{P}\right)^{\frac{1}{n}} \right].$$

This may be increased 5 to 10 per cent, to allow for air friction, air heating, etc.

231. Design of Compressor. The following data must be assumed:

- (a) capacity, or piston displacement,
- (b) maximum pressure,
- (c) initial pressure and temperature,
- (d) temperature of cooling water,
- (e) gas to be compressed, if other than air.

Let the compressor deliver 300 cu. ft. of compressed air, measured at 70° F., per minute, against 100 lb. gauge pressure, drawing its supply at 14.7 lb. and 70° F., the clearance being 2 per cent. Then, ideally, the free air per minute will be $300 \times (114.7 \div 14.7) = 2341$ cu. ft., or allowing 5 per cent for losses due to air friction and heating during the suction, $2341 \div 0.95 = 2464$ cu. ft. To allow for clearance, we may use the expression in Art. 230, making the displacement, with adiabatic expansion of the clearance air,

$$P_D V_D^{1.35} = P_I V_I^{1.35} \text{ or } V_I = \left(\frac{P_D}{P_I}\right)^{0.74} V_D = \left(\frac{114.7}{13.7}\right)^{0.74} 0.04 D = 0.1927 D.$$

$$P_E V_E^{1.35} = P_C V_C^{1.35} \text{ or } V_E = \left(\frac{P_C}{P_E}\right)^{0.74} V_C = \left(\frac{13.7}{114.7}\right)^{0.74} 1.04 D = 0.2158 D.$$

$$P_A V_A^{1.35} = P_D V_D^{1.35} \text{ or } V_A = \left(\frac{P_D}{P_A}\right)^{0.74} V_D = \left(\frac{114.7}{14.7}\right)^{0.74} 0.04 D = 0.1829 D.$$

$$P_B V_B^{1.35} = P_C V_C^{1.35} \text{ or } V_B = \left(\frac{P_C}{P_B}\right)^{0.74} V_C = \left(\frac{13.7}{14.7}\right)^{0.74} 1.04 D = 0.9872 D.$$

But $AB = V_B - V_A = 0.8043 D$ is the volume of free air drawn into the cylinder: $AB \div GH = 0.8043$ is the volumetric efficiency:* to compress 4000 cu. ft. of free air per minute the piston displacement must then be $4000 \div 0.8043 = 4973$ cu. ft. per minute. Since the compressor is double-acting, the necessary cylinder area is the quotient of displacement by piston speed or $4973 \div 640$, giving 7.77 sq. ft., or (neglecting the loss of area due to the piston rod), the cylinder diameter is 37.60 in. From the conditions of the problem, the stroke is $640 \div (2 \times 80) = 4$ ft.

For the power consumption, we have

$$\begin{aligned} W &= GDEF + FECH - JICH - GDIJ \\ &= P_E(V_E - V_D) + \frac{P_E V_E - P_C V_C}{0.35} - P_I(V_C - V_I) - \frac{P_D V_D - P_I V_I}{0.35} \\ &= 144 D \left[(114.7 \times 0.1758) + \frac{(114.7 \times 0.2158) - (13.7 \times 1.04)}{0.35} \right. \\ &\quad \left. - (13.7 \times 0.8473) - \frac{(114.7 \times 0.04) - (13.7 \times 0.1927)}{0.35} \right] \\ &= 144 D [20.16 + 30.01 - 11.61 - 5.59] = 144 D \times 32.97. \end{aligned}$$

This is the work for a piston displacement = D cubic feet. If we take D at 4973 per minute, the horse power consumed in compression is

$$\frac{144 \times 32.97 \times 4973}{33000} = 715.$$

234. Design of a Two-stage Machine. With conditions as in the preceding, consider a two-stage compressor with complete intercooling and a uniform friction of one pound between the stages. Here the combined diagrams appear as in Fig. 85. For economy of power, the intermediate pres-

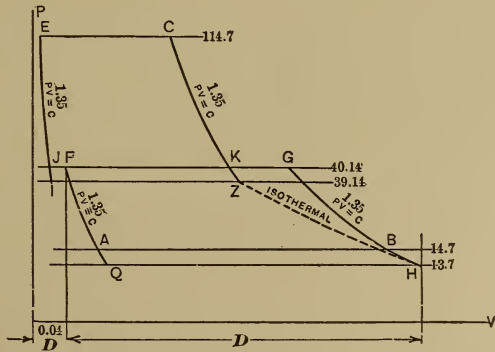

FIG. 85. Art. 234. — Design of Two-stage Compressor.

* This is not quite correct, because the air at B is not "free" air, i.e., air at atmospheric temperature. There is a slight rise in temperature between C and B . If T_R is the atmospheric temperature, and $b = \frac{V_B}{D}$, $a = \frac{V_A}{D}$, the volumetric efficiency is $T_R \left(\frac{b}{T_B} - \frac{a}{T_A} \right)$. If there is no cooling during discharge (along GF), $T_A = T_B$, and the volumetric efficiency becomes $\frac{T_R}{T_B} (b - a)$.

sure is $\sqrt{114.7 \times 13.7} = 39.64$, whence the first-stage discharge pressure and the second-stage suction pressure, corrected for friction, are respectively 40.14 and 39.14 lb. For the *first stage*, Fig. 85,

$$P_F = P_G = 40.14, P_A = P_B = 14.7, P_Q = P_H = 13.7, V_H = 1.04 D, V_F = 0.04 D.$$

$$P_G V_G^{1.35} = P_H V_H^{1.35} \text{ or } V_G = \left(\frac{P_H}{P_G}\right)^{0.74} V_H = \left(\frac{13.7}{40.14}\right)^{0.74} 1.04 D = 0.4701 D. *$$

$$P_Q V_Q^{1.35} = P_F V_F^{1.35} \text{ or } V_Q = \left(\frac{P_F}{P_Q}\right)^{0.74} V_F = \left(\frac{40.14}{13.7}\right)^{0.74} 0.04 D = 0.08864 D.$$

$$P_A V_A^{1.35} = P_F V_F^{1.35} \text{ or } V_A = \left(\frac{P_F}{P_A}\right)^{0.74} V_F = \left(\frac{40.14}{14.7}\right)^{0.74} 0.04 D = 0.08412 D.$$

$$P_B V_B^{1.35} = P_H V_H^{1.35} \text{ or } V_B = \left(\frac{P_H}{P_B}\right)^{0.74} V_H = \left(\frac{13.7}{14.7}\right)^{0.74} 1.04 D = 0.987 D.$$

The *volumetric efficiency* is $AB \div D = (V_B - V_A) \div D = 0.987 - 0.08412 = 0.90288$. The *piston displacement* per minute is $4000 \div 0.903 = 4430$. The piston diameter is $\sqrt{(4430 \div 640) \times 144 \div 0.7854} = 35.6$ in. for a *stroke* of $640 \div (2 \times 80) = 4$ ft. The *power consumption* for this first stage is,

$$\begin{aligned} W &= P_G(V_G - V_F) + \frac{P_G V_G - P_H V_H}{n-1} - P_H(V_H - V_Q) - \frac{P_F V_F - P_Q V_Q}{n-1} \\ &= \left[40.14(0.4701 - 0.04) + \frac{(40.14 \times 0.4701) - (13.7 \times 1.04)}{0.35} \right. \\ &\quad \left. - 13.7(1.04 - 0.0886) - \frac{(40.14 \times 0.04) - (13.7 \times 0.0886)}{0.35} \right] 144 D \\ &= 2348.64 D \text{ foot-pounds or } 10,404,475 \text{ foot-pounds per minute, equivalent to } \\ &315.3 \text{ horse power.} \end{aligned}$$

SECOND STAGE

Complete intercooling means that at the beginning of compression in the second stage the temperature of the air will be as in the first stage, 70° F. The volume at this point will then be $V_Z = \frac{P_H}{P_Z} V_H = \frac{13.7}{39.14} 1.04 D = 0.364 D$. We thus locate the point Z, Fig. 85, and complete the diagram ZCEI, making $V_E = 0.04$ ($V_Z - V_E$) = 0.014 D, $P_C = P_E = 114.7$, $P_I = P_Z = 39.14$, and compute as follows:

$$P_K V_K^{1.35} = P_Z V_Z^{1.35} \text{ or } V_K = \left(\frac{P_Z}{P_K}\right)^{0.74} V_Z = \left(\frac{39.14}{40.14}\right)^{0.74} 0.364 D = 0.3574 D.$$

$$P_C V_C^{1.35} = P_Z V_Z^{1.35} \text{ or } V_C = \left(\frac{P_Z}{P_C}\right)^{0.74} V_Z = \left(\frac{39.14}{114.7}\right)^{0.74} 0.364 D = 0.1642 D.$$

$$P_J V_J^{1.35} = P_E V_E^{1.35} \text{ or } V_J = \left(\frac{P_E}{P_J}\right)^{0.74} V_E = \left(\frac{114.7}{40.14}\right)^{0.74} 0.014 D = 0.0305 D.$$

$$P_I V_I^{1.35} = P_E V_E^{1.35} \text{ or } V_I = \left(\frac{P_E}{P_I}\right)^{0.74} V_E = \left(\frac{114.7}{39.14}\right)^{0.74} 0.014 D = 0.0311 D.$$

* Note that $\frac{P_C}{P_Z} = \frac{P_G}{P_H}$, very nearly; so that $\frac{V_G}{V_H} = \frac{V_F}{V_Q} = \frac{V_C}{V_Z} = \frac{V_E}{V_I}$; an approximation which makes only one logarithmic computation necessary.

The piston displacement is $V_Z - V_B = 0.35 D$; the volumetric efficiency is the quotient of $(V_K - V_J) = 0.3269 D$ by this displacement, or 0.934. For a stroke of 4 ft., the cylinder diameter is $\sqrt{[(0.35 D = 1550) \div 640] \times 144 \div 0.7854} = 21.05$ in. The power consumption for this stage is

$$W = \frac{144 D}{33000} \left[(114.7 \times 0.1502) + \frac{(114.7 \times 0.1642) - (39.14 \times 0.364)}{0.35} \right. \\ \left. - (39.14 \times 0.3329) - \frac{(114.7 \times 0.014) - (39.14 \times 0.0311)}{0.35} \right] \\ = 316.5 \text{ horse power.}$$

The total horse power for the two-stage compressor is then 631.8 and (within the limit of the error of computation) the work is equally divided between the stages.

235. Comparisons. We note, then, that in two-stage compression, the saving in power is $\frac{715 - 632}{715} = 0.12$ of the power expended in single-stage compression;

that the low-pressure cylinder of the two-stage machine is somewhat smaller than the cylinder of the single-stage compressor; and that, in the two-stage machine, the cylinder areas are (approximately) inversely proportional to the suction pressures. The amount of cooling water required will be found to be several times that necessary in the single-stage compressor.

236. Power Plant Applications. On account of the ease of solution of air in water, the boiler feed and injection waters in a power plant always carry a considerable quantity of air with them. The vacuum pump employed in connection with a condenser is intended to remove this air as well as the water. It is estimated that the waters ordinarily contain about 20 times their volume of air at atmospheric pressure. The pump must be of size sufficient to handle this air when expanded to the pressure in the condenser. Its cycle is precisely that of any air compressor, the suction stroke being at condenser pressure and the discharge stroke at atmospheric pressure. The water present acts to reduce the value of the exponent n , thus permitting of fair economy.

237. Dry Vacuum Pumps. In some modern forms of high vacuum apparatus, the air and water are removed from the condenser by separate pumps. The amount of air to be handled cannot be computed from the pressure and temperature directly, because of the water vapor with which it is saturated. From Dalton's law, and by noting the temperature and pressure in the condenser, the pressure of the air, separately considered, may be computed. Then the volume of air, calculated as in Art. 236, must be reduced to the condenser temperature and pressure, and the pump made suitable for handling this volume (14).

COMMERCIAL TYPES OF COMPRESSING MACHINERY

238. Classification of Compressors. Air compressors are classified according to the number of stages, the type of frame, the kind of valves, the method of driving, etc. Steam-driven compressors are usually mounted as one unit with the steam cylinders and a single common fly wheel. Regulation is usually effected by varying the speed. The ordinary centrifugal governor on the steam cylinder imposes a maximum speed limit; the shaft governor is controlled by the air pressure, which automatically changes the point of cut-off on the steam cylinder. Power-driven compressors may be operated by electric motor, belt, water wheel, or in

other ways. They are usually regulated by means of an "unloading valve," which either keeps the suction valve closed during one or more strokes or allows the air to discharge into the atmosphere whenever the pipe lines are fully supplied. In air lift practice, a constant speed is sometimes desired, irrespective of the load.

In the "variable volume" type of machine, the delivery of the compressor is varied by closing the suction valve before the completion of the suction stroke. The air in the cylinder then expands below atmospheric pressure.

239. Standard Forms. The ordinary small compressor is a single-stage machine, with poppet air valves on the sides of the cylinder. The frame is of the "fork" pattern, with bored guides, or of the "duplex" type, with two single-stage cylinders. These machines may be either steam or belt driven. The "straight line" compressors differ from the duplex in having all of the cylinders in one straight line, regardless of their number.

For high-grade service, in large units, the standard form is the cross-compound two-stage machine, the low-pressure steam and air cylinders being located tandem beside the high-pressure cylinders, and the air cylinders being outboard, as in Fig. 86. Ordinary standard machines of this class are built in capacities ranging up to 6000 cu. ft. of free air per minute. The other machines are usually constructed only in smaller sizes, ranging down to as small as 100 cu. ft. per minute.

Some progress has been made in the development of rotary compressors for direct driving by steam turbines. The efficiency is fully as high as that of an ordinary reciprocating compressor, and the mechanical losses are much less. A paper by Rice (*Jour. A. S. M. E.* xxxiii, 3) describes a 6-stage turbo-machine at 1650 r. p. m., direct-connected to a 4-stage steam turbine. With the low discharge pressure (15 lb. gauge), numerous stages and intercoolers, compression is practically isothermal.

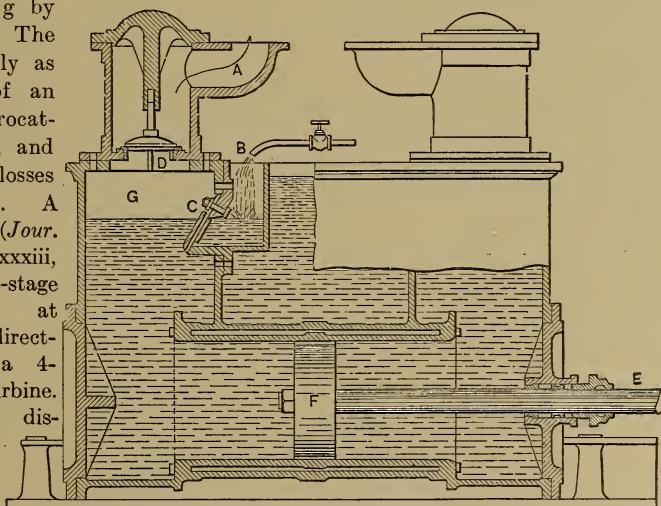

FIG. 87. Art. 240. — Sommeiller Hydraulic Piston Compressor.

240. Hydraulic Piston Compressors: Sommeiller's. In Fig. 87, as the piston *F* moves to the right, air is drawn through *C* to *G*, together with cooling water from *B*. On the return stroke, the air is compressed and discharged through *D* and *A*. Indicator diagrams are given in Fig. 88.

The value of n is exceptionally low, and clearance expansion almost eliminated. This was the first commercial piston compressor, and it is still used to a

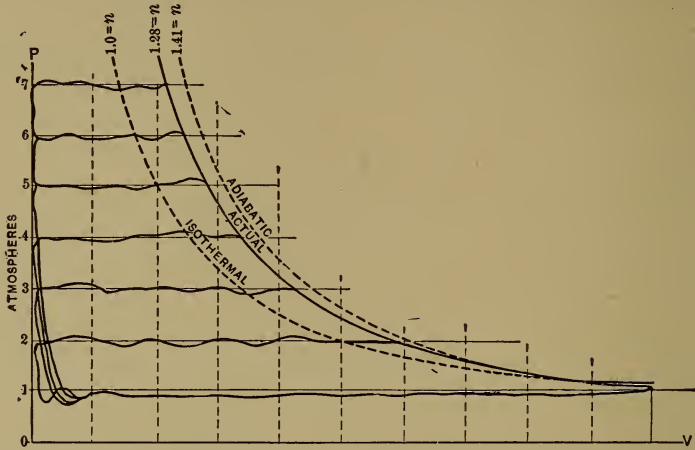

FIG. 88. Art. 240. — Variable Discharge Pressure Indicator Diagrams, Sommeiller Compressor.

limited extent in Europe, the large volume of water present giving effective cooling. It cannot be operated at high speeds, on account of the inertia of the water.

The Leavitt hydraulic piston compressor at the Calumet and Hecla copper mines, Michigan, has double-acting cylinders 60 by 42 in., and runs at 25 revolutions per minute, a comparatively high speed. The value of n from the card shown in Fig. 89 is 1.23.

241. Taylor Hydraulic Compressor.

Water is conducted through a vertical shaft at the necessary head (2.3 ft. per pound pressure) to a separating cham-

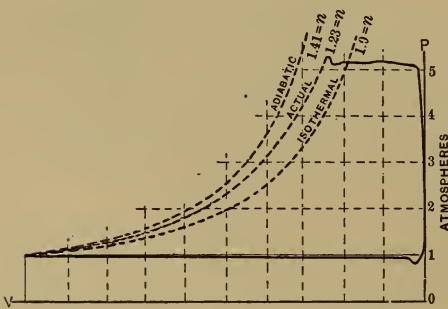

FIG. 89. Art. 248. — Cards from Leavitt Compressor.

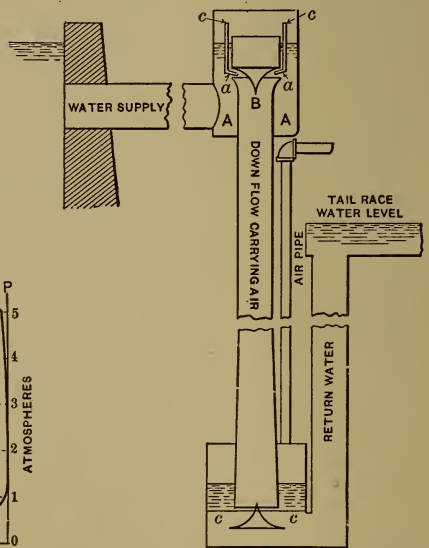

FIG. 90. Art. 241. — Taylor Hydraulic Compressor.

ber. The shaft is lined with a riveted or a cast-iron cylinder, and at its top is a dome, located so that the water flows downward around the inner circumference of the cylinder. The dome is so made that the water alternately contracts and expands during its passage, producing a partial vacuum, by means of which air is drawn in through numerous small pipes. The air is compressed **at the temperature of the water** while descending the shaft. The separating chamber is so large as to permit of separation of the air under an inverted bell, from which it is led by a pipe. The efficiency, as compared with that theoretically possible in isothermal compression, is 0.60 to 0.70, some air being always carried away in solution. The initial cost is high, and the system can be installed only where a head of water is available. Figure 90 illustrates the device (15). The head of water must be at least equal to that corresponding to the pressure of air.

The "cycle" of this type of compressor may be regarded as made up of two constant pressure paths and an isothermal, there being no clearance and no "valve friction."

242. Details of Construction. The standard form of *cylinder* for large machines is a two-piece casting, the working barrel being separate from the jacket, so that the former may be a good wearing metal and may be quite readily removable. Access to the jacket space is provided through bolt holes.

On the smaller compressors, the poppet type of *valve* is frequently used for both inlet and discharge (Fig. 91). It is usually considered best to place these valves

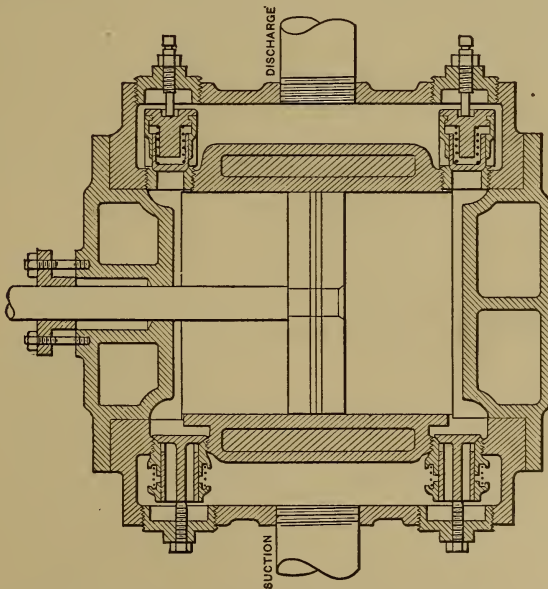

FIG. 91. Art. 242. — Compressor Cylinder with Poppet Valves.
(Clayton Air Compressor Works.)

in the head, thus decreasing the clearance. They are satisfactory valves for automatically controlling the point of discharge, excepting that they are occasionally

noisy and uncertain in closing, and if the springs are made stiff for tightness, a considerable amount of power may be consumed in opening the valves. Poppet valves work poorly at very low pressures, and are not generally used for controlling the intake of air. Some form of mechanically operated valve is preferably employed, such as the semi-rocking type of Fig. 92, located at the bottom of the cylinder, which has poppet valves for the discharge at the top. For large units, Corliss inlet valves are usually employed, these being rocking cylindrical valves running crosswise. As in steam engines, they are so driven from an eccentric and wrist plate as to give rapid opening and closing of the port, with a comparatively slow intervening movement. They are not suitable for use as discharge valves in single-stage compressors, or in the high-pressure cylinders of multi-stage compressors, as they become fully open too late in the stroke to give a sufficiently free discharge. In Fig. 93 Corliss valves are used for both inlet and discharge. The auxiliary poppet shown is used as a safety valve.

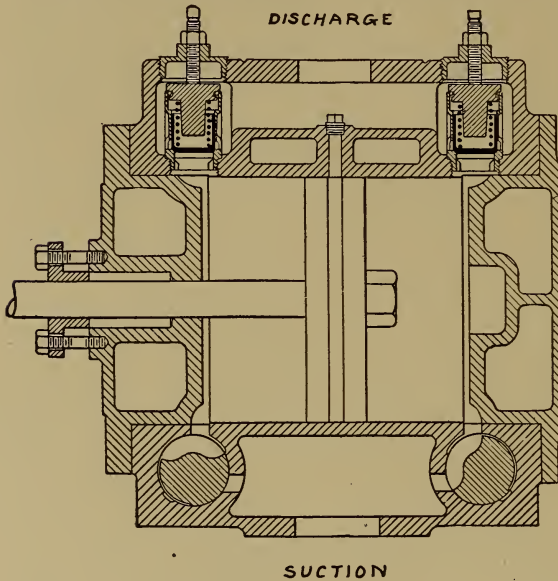

FIG. 92. Art. 242. — Compressor Cylinder with Rocking Inlet Valves. (Clayton Air Compressor Works.)

employed, these being rocking cylindrical valves running crosswise. As in steam engines, they are so driven from an eccentric and wrist plate as to give rapid opening and closing of the port, with a comparatively slow intervening movement. They are not suitable for use as discharge valves in single-stage compressors, or in the high-pressure cylinders of multi-stage compressors, as they become fully open too late in the stroke to give a sufficiently free discharge. In Fig. 93 Corliss valves are used for both inlet and discharge. The auxiliary poppet shown is used as a safety valve.

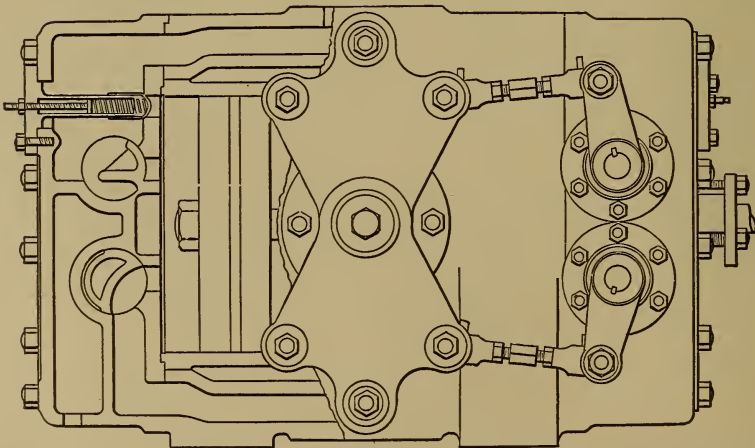

FIG. 93. Art. 242. — Compressor Cylinder with Corliss Valves. (Allis-Chalmers Co.)

A gear sometimes used consists of Corliss inlet valves and mechanically operated discharge valves, which latter, though expensive, are free from the disadvantages sometimes experienced with poppet valves. The closing only of these valves is mechanically controlled. Their opening is automatic.

A common rule for proportioning valves and passages is that the average velocity of the air must not exceed 6000 ft. per minute.

COMPRESSED AIR TRANSMISSION

243. Transmissive Losses. The air falls in temperature and pressure in the pipe line. The fall in temperature leads to a decrease in volume, which is further reduced by the condensation of water vapor; the fall in pressure tends to increase the volume. Early experiments at Mont Cenis led to the empirical formula $F = 0.00000936 (n^2 l + d)$, for a loss of pressure F in a pipe d inches in diameter, l ft. long, in which the velocity is n feet per second (16).

In the Paris distributing system, the main pipe was 300 mm. in diameter, and about $\frac{3}{8}$ in. thick, of plain end cast iron lengths connected with rubber gaskets. It was laid partly under streets and sidewalks, and partly in sewers, involving the use of many bends. There were numerous drainage boxes, valves, etc., causing resistance to the flow; yet the loss of pressure ranged only from 3.7 to 5.1 lb., the average loss at 3 miles distance being about 4.4 lb., these figures of course including leakage. The percentage of air lost by leakage was ascertained to vary from 0.38 to 1.05, including air consumed by some small motors which were unintentionally kept running while the measurements were made. This loss would of course be proportionately much greater when the load was light.

244. Unwin's Formula. Unwin's formula for terminal pressure after long transmission is commonly employed in calculations for pipe lines (17). It is,

$$p = P \left[1 - \frac{fu^2L}{430Td} \right]^{\frac{1}{2}},$$

in which p = terminal pressure in pounds per square inch,

P = initial pressure in pounds per square inch,

f = an experimental coefficient,

u = velocity of air in feet per second,

L = length of pipe in feet,

d = diameter of (circular) pipe in feet,

T = absolute temperature of the air, F° .

A simple method of determining f is to measure the fall of pressure under known conditions of P , u , T , L , and d , and apply the above formula. Unwin has in this way rationalized the results of Riedler's experiments on the Paris distributing system, obtaining values ranging from 0.00181 to 0.00449, with a mean value $f = 0.00290$. For pipes over one foot in diameter, he recommends the value 0.003; for 6-inch pipe, $f = 0.00435$; for 8-inch pipe, $f = 0.004$.

Riedler and Gutermuth found it possible to obtain pipe lengths as great as 10 miles in their experiments at Paris. Previous experiments had been made, on

a smaller scale, by Stockalper. For cast-iron pipe, a harmonization of these experiments gives $f = 0.0027(1 + 0.3d)$, d being the diameter of the pipe in feet. The values of f for ordinary wrought pipe are probably not widely different. In any well-designed plant, the pressure loss may be kept very low.

245. Storage of Compressed Air. Air is sometimes stored at very high pressures for the operation of locomotives, street cars, buoys, etc. An important consequence of the principle illustrated in Joule's porous plug experiment (Art. 74) here comes into play. It was remarked in Art. 74 that a slight fall of temperature occurred during the reduction of pressure. This was expressed by Joule by the formula

$$F = 0.92 \left(\frac{273.7}{T} \right)^2,$$

in which F was the fall of temperature in degrees Centigrade for a pressure drop of 100 inches of mercury when T was the initial absolute temperature (Centigrade) of the air. For air at 70° F., this fall is only 1½° F., but when stored air at high pressure is expanded through a reducing valve for use in a motor, the pressure change is frequently so great that a considerable reduction of temperature occurs. The efficiency of the process is very low; Peabody cites an instance (18) in which with a reservoir of 75 cu. ft. capacity, carrying 450 lb. pressure, with motors operating at 50 lb. pressure and compression in three stages, the maximum computed plant efficiency is only 0.29. An element of danger arises in compressed air storage plants from the possibility of explosion of minute traces of oil at the high temperatures produced by compression.

246. Liquefaction of Air; Linde Process (19). The fall of temperature accompanying a reduction of pressure has been utilized by Linde and others in the manufacture of liquid air. Air is compressed to about 2000 lb. pressure in a three-stage machine, and then delivered to a cooler. This consists of a double tube about 400 ft. long, arranged in a coil. The air from the compressor passes through the inner tube to a small orifice at its farther end, where it expands into a reservoir, the temperature falling, and returns through the outer tube of the cooler back to the compressor. At each passage, a fall of temperature of about 37½° C. occurs. The effect is cumulative, and the air soon reaches a temperature at which the pressure will cause it to liquefy (Art. 610).

247. Refrigeration by Compressed Air. This subject will be more particularly considered in a later chapter. The fall of temperature accompanying expansion in the motor cylinder, with the difficulties which it occasions, have been mentioned in Art. 185. Early in the Paris development, this drop of temperature was utilized for refrigeration. The exhaust air was carried through flues to wine cellars, where it served for the cooling of their contents, the production of ice, etc. In some cases, the refrigerative effect alone is sought, the performance of work during the expansion being incidental.

(1) As text books on the commercial aspects of this subject Peele's *Compressed Air Plant* (John Wiley & Sons) and Wightman's *Compressed Air* (American School of

Correspondence, 1909), may be consulted. (1a) Riedler, *Neue Erfahrungen über die Kraftversorgung von Paris durch Druckluft*, Berlin, 1891. (2) Pernolet (*L'Air Comprimé*) is the standard reference on this work. (3) *Experiments upon Transmission*, etc. (Idell ed.), 1903, 98. (4) Unwin, *op. cit.*, 18 *et seq.* (5) Unwin, *op. cit.*, 32. (6) *Graduating Thesis*, Stevens Institute of Technology, 1891. (7) Unwin, *op. cit.*, 48. (8) *Op. cit.*, 109. (9) Unwin, *op. cit.*, 48, 49; some of the final figures are deduced from Kennedy's data. (10) *Power*, February 23, 1909, p. 382. (11) *Development and Transmission of Power*, 182. (12) *Engineering News*, March 19, 1908, 325. (13) Peabody, *Thermodynamics*, 1907, 378. (14) *Ibid.*, 375. (15) Hiscox, *Compressed Air*, 1903, 273. (16) Wood, *Thermodynamics*, 1905, 306. (17) *Transmission by Compressed Air*, etc., 68; modified as by Peabody. (18) *Thermodynamics*, 1907, 393, 394. (19) Zeuner, *Technical Thermodynamics* (Klein); II, 303-313: *Trans. A. S. M. E.*, XXI, 156.

SYNOPSIS OF CHAPTER IX

The use of compressed cold air for power engines and pneumatic tools dates from 1860.

The Air Engine

The ideal air engine cycle is bounded by *two constant pressure lines, one constant volume line, and a polytropic*. In practice, a *constant volume drop* also occurs after expansion.

Work formulas:

$$pv + pv \log_e \frac{V}{v} - qV; \quad pv + \frac{pv - PV}{n-1} - qV; \quad pv \log_e \frac{V}{v}; \quad (pv - PV) \left(\frac{y}{y-1} \right).$$

Preheaters prevent excessive drop of temperature during expansion; the heat employed is not wasted.

Cylinder volume = 33,000 $NRt \div 2nUp$, ignoring clearance.

To ensure quiet running, the exhaust valve is closed early, the clearance air acting as a cushion. This modifies the cycle.

Early closing of the exhaust valve also *reduces the air consumption*.

Actual figures for free air consumption range from 400 to 2400 cu. ft. per *Ihp-hr.*

The Compressor

The cycle *differs from that of the engine* in having a sharp "toe" and a complete clearance expansion curve.

Economy depends largely on the *shape of the compression curve*. Close approximation to the *isothermal*, rather than the *adiabatic*, should be attained, as during expansion in the engine. This is attempted by air cooling, jet and spray injection of water, and jacketing. *Water required* = $C = H \div (S - s)$.

$$H(\text{heat to be abstracted}) = \frac{PV}{n-1} \left[\left(\frac{p}{P} \right)^{\frac{n-1}{n}} - 1 \right] + \frac{PV}{y-1} - \frac{pV}{y-1} \left(\frac{P}{p} \right)^{\frac{1}{y}}$$

Multi-stage operation improves the *compression curve* most notably and is in other respects beneficial.

Intercooling leads to friction losses but is *essential to economy*; must be thorough.

Work, neglecting clearance (single cylinder), $= W = \frac{P_n V}{n-1} \left[\left(\frac{p}{P} \right)^{\frac{n-1}{n}} - 1 \right]$.

The area under the compression curve is called the *work of compression*.

Minimum work, in two-stage compression, is obtained when $P^2 = qp$.

Engine and Compressor Relations

Compressive efficiency: ratio of engine work to compressor work; *0.5 to 0.9*.

Mechanical efficiency: ratio of work in cylinder and work at shaft; *0.80 to 0.90*.

Cylinder efficiency: ratio of ideal diagram area and actual diagram area; *0.70 to 0.90*.

Plant efficiency: ratio of work delivered by air engine to work expended at compressor shaft; *0.25 to 0.45*; theoretical maximum, *1.00*.

The combined *ideal entropy diagram* is bounded by *two constant pressure curves and two polytropics*. The economy of *thorough intercooling* with multi-stage operation is shown; as is the importance of a *low exponent* for the polytropics. With very cold water, the net power consumption might be *negative*.

Compressor Capacity

Volumetric efficiency = ratio of free air drawn in to piston displacement; it is decreased by *excessive clearance, suction friction, heating during suction*, and installation at *high altitudes*. *Long stroke compressors* have proportionately less clearance. *Water* may be used to *fill the clearance space*: multi-stage operation makes clearance less detrimental; *refrigeration of the entering air* increases the volumetric efficiency. Its *value* ranges ordinarily from *0.70 to 0.92*. *Suction friction and clearance also decrease the cylinder efficiency*, as does *discharge friction*.

Compressor Design

Theoretical piston displacement per stroke $= \frac{pvT}{2ntP}$, or including clearance,

$$\frac{pvT}{2nPt} \div \left[1 - \frac{1}{m} \left(\frac{p}{P} \right)^{\frac{1}{n}} + \frac{1}{m} \right],$$

to be increased *5 to 10 per cent* in practice.

In a multi-stage compressor with perfect intercooling, *the cylinder volumes are inversely as the suction pressures*.

The power consumed in compression may be calculated for any assumed compressive path.

A typical problem shows a *saving of 12 per cent* by two-stage compression.

The "*vacuum pump*" used with a condenser is an air compressor.

Commercial Types of Compressing Machinery

Classification is by *number of stages, type of frame or valves, or method of driving*.

Governing is accomplished by *changing the speed, the suction, or the discharge pressure*.

Commercial types include the *single, duplex, straight line and cross-compound two-stage forms*, the last having capacities up to *6000 cu. ft. per minute*. Some progress has been made with *turbo-compressors*.

Hydraulic piston compressors give high efficiency at low speeds.

The *Taylor hydraulic compressor* gives efficiencies up to *0.69 or 0.70*.

Cylinder barrels and jackets are separate castings. Access to water space must be provided.

Poppet, mechanical inlet, Corliss, and mechanical discharge valves are used.

Compressed Air Transmission

Loss in pressure = $0.00000936n^2l \div d$.

In *Paris*, the total loss in 3 miles, including leakage, was 4.4 lb.; the percentage of leakage was 0.38 to 1.05, including air unintentionally supplied to consumers.

Unwin's formula; $p = P \left[1 - \frac{fu^2 L}{430 Td} \right]^{\frac{1}{2}}$. Mean value of $f = 0.0029$, $f = 0.0027(1 + 0.3d)$.

Fall of temperature for 49 lb. fall of pressure by throttling = $0.92 \left(\frac{273.7}{T} \right)^2$.

Stored high pressure air may be used for driving motors, but the *efficiency is low*.

The fall of temperature induced by throttling may be used cumulatively to *liquefy air*.

The fall of temperature accompanying expansion in the engine may be employed for *refrigeration*.

PROBLEMS

1. An air engine works between pressures of 180 lb. and 15 lb. per square inch, absolute. Find the work done per cycle with adiabatic expansion from $v = 1$ to $V = 4$, ignoring clearance. By what percentage would the work be increased if the expansion curve were $PV^{1.3} = c$? (*Ans.*, 44,800 ft. lb; 4.3 %.)

2. The expansion curve is $PV^{1.3} = c$, the pressure ratio during expansion 7 : 1, the initial temperature 100° F. Find the temperature after expansion. To what temperature must the entering air be heated if the final temperature is to be kept above 32° F.? (*Ans.*, -103° F.; 310° F.)

3. Find the cylinder dimensions for a double-acting 100 hp. air engine with clearance 4 per cent, the exhaust pressure being 15 lb. absolute, the engine making 200 r. p. m., the expansion and compression curves being $PV^{1.35} = c$, and the air being received at 160 lb. absolute pressure. Compression is carried to the maximum pressure, and the piston speed is 400 ft. per minute. A 10-lb. drop of pressure occurs at the end of expansion. (Allow a 10 per cent margin over the theoretical piston displacement.) (*Ans.*, 13.85 ins. by 12.0 ins.)

4. Estimate the free air consumption per Ihp.-hr. in the engine of Problem 3.

(*Ans.*, 612 cu. ft.)

5. A hydrogen compressor receives its supply at 70° F. and atmospheric pressure, and discharges it at 100 lb. gauge pressure. Find the temperature of discharge, if the compression curve is $PV^{1.32} = c$. (*Ans.*, 412° F.)

6. In Problem 5, what is the percentage of power wasted as compared with isothermal compression, the cycles being like *CBAD*, Fig. 57?

7. In Problem 3, the initial temperature of the expanding air being 100° F., find what quantity of heat must have been added during expansion to make the path $PV^{1.35} = c$ rather than an adiabatic. Assuming this to be added by a water jacket, the water cooling through a range of 70°, find the weight of water circulated per minute.

8. Find the receiver pressures for minimum work in two and four-stage compression of atmospheric air to gauge pressures of 100, 125, 150, and 200 lb.

9. What is the minimum work expenditure in the cycle compressing free air at 70° F. to 100 lb. gauge pressure, per pound of air, along a path $PV^{1.35} = c$, clearance being ignored? (*Ans.*, 76,600 ft. lb.)

10. Find the cylinder efficiency in Problem 3, the pressure in the pipe line being 165 lb. absolute. (*Ans.*, 62.5%.)

11. Sketch the entropy diagram for a four-stage compressor and two-stage air

engine, in which n is 1.3 for the compressor and 1.4 for the engine, the air is inadequately intercooled, perfectly aftercooled, and inadequately preheated between the engine cylinders. Compare with the entropy diagram for adiabatic paths and perfect intercooling and such preheating as to keep the temperature of the exhaust above 32° F.

12. Find the cylinder dimensions and theoretical power consumption of a single-acting single-stage air compressor to deliver 8000 cu. ft. of free air per minute at 180 lb. absolute pressure at 60 r. p. m., the intake air being at 13.0 lb. absolute pressure, the piston speed 640 ft. per minute, clearance 3 per cent, and the expansion and compression curves following the law $PV^{1.31}=c$. (*Ans.*, 80 by 64 in.)

13. With conditions as in Problem 12, find the cylinder dimensions and power consumption if compression is in two stages, intercooling is perfect, and 2 lb. of friction loss occurs between the stages. (*Ans.*, 74 by 38 by 64 in.)

14. The cooling water rising from 68° F. to 89° F. in temperature, in Art. 233, find the water consumption in gallons per minute. (*Ans.*, 170.)

15. Find the water consumption for jackets and intercooling in Art. 234, the range of temperature of the water being from 47° to 68° F. (*Ans.* 714 gal. per min.)

16. Find the cylinder volume of a pump to maintain 26'' vacuum when pumping 100 lb. of air per hour, the initial temperature of the air being 110° F., compression and expansion curves $PV^{1.28}=c$, clearance 6 per cent., and the pump having two double-acting cylinders. The speed is 60 r. p. m. Pipe friction may be ignored.

17. Compare the Riedler and Gutermuth formula for f (Art. 244) with Unwin's values. What apparent contradiction is noticeable in the variation of f with d ?

18. In a compressed air locomotive, the air is stored at 2000 lb. pressure and delivered to the motor at 100 lb. Find the temperature of the air delivered to the motor if that of the air in the reservoir is 80° F., assuming that the value of F (Art. 245) is directly proportional to the pressure drop.

19. With isothermal curves and no friction, transmission loss, or clearance, what would be the combined efficiency from compressor to motor of an air storage system in which the storage pressure was 450 lb. and the motor pressure 50 lb.? The temperature of the air is 80° F. at the motor reducing valve. (Assume that the formula in Art. 245 holds, and that the temperature drop is a direct function of the pressure drop.)

20. Find by the Mont Cenis formula, the loss of pressure in a 12-in. pipe 2 miles long in which the air velocity is 32 ft. per second. Compare with Unwin's formula, using the Riedler and Gutermuth value for f , assuming $P=80$, $T=70°$ F.

21. Find the free air consumption per Ihp.-hr. if the action of the engine in Art. 190 is modified as suggested in Art. 191.

22. Find under what initial pressure condition, in Art. 183, an output of 1.27 Ihp. may theoretically be obtained from 890 cu. ft. of free air per hour, the exhaust pressure being that of the atmosphere, and the expansive path being (a) isothermal, (b) adiabatic. (*Ans.*, (a), 56 lb. absolute.)

23. A compressor having a capacity of 500 cu. ft. of free air per minute ($p=14.7$, $t=70°$) is required to fill a 700 cu. ft. tank at a pressure of 2500 lb. per square inch. How long will this require, if the temperature in the tank is 140° at the end of the operation, and the discharge pressure is constant?

24. In Problem 16, what is the theoretical minimum amount of power that might be consumed, with no clearance and no abstraction of heat during compression? How does this compare with the power consumption in the actual case?

25. A Taylor hydraulic compressor (Art. 241), with water at 40°, compresses air to 50 lb. gauge pressure. If the efficiency is 0.65 of that possible in isothermal compression, find the horse power consumed in compressing 4000 cu. ft. of free air per minute,

CHAPTER X

HOT-AIR ENGINES

248. General Considerations. From a technical standpoint, the class of air engines includes all heat motors using any permanent gas as a working substance. For convenience, those engines in which the fuel is ignited inside the cylinder are separately discussed, as *internal combustion* or *gas* engines (Chapter XI). The air engine proper is an *external combustion* engine, although in some types the products of combustion do actually enter the cylinder; a point of mechanical disadvantage, since the corrosive and gritty gases produce rapid wear and leakage. The air engine employs, usually, a *constant mass of working substance*, *i.e.*, the same body of air is alternately heated and cooled, none being discharged from the cylinder and no fresh supply being brought in; though this is not always the case. Such an engine is called a "closed" engine. Any fuel may be employed; the engines require little attention; there is no danger of explosion.

Modern improvements on the original Stirling and Ericsson forms of air engine, while reducing the objections to those types, and giving excellent results in fuel economy, are, nevertheless, limited in their application to small capacities, as for domestic pumping service. The recent development of the gas engine (Chapter XI) has further served to minimize the importance of the hot-air cycle.

In air, or any perfect gas, the temperature may be varied independently of the pressure; consequently, the limitation referred to in Art. 143 as applicable to steam engines does not necessarily apply to air engines, which may work at much higher initial temperatures than any steam engine, their potential efficiency being consequently much greater. When a specific cycle is prescribed, however, as we shall immediately find, pressure limits may become of importance.

249. Capacity. One objection to the air engine arises from the extremely slow transmission of heat through metal surfaces to dry gases. This is partially overcome in various ways, but the still serious objection is the small capacity for a given size. If the Carnot cycle be plotted for one pound of air, as in Fig. 94, the enclosed work area is seen to be very small, even for a considerable range of pressures. The isothermals and adiabatics very nearly coincide. For a given output, therefore, the air engine must be excessively large at anything like reasonable maximum pressures. In the Ericsson engine (Art. 269), for example, although the cycle was one giving a larger work area than that of Carnot, four cylinders were required, each having a diameter of 14 ft. and a stroke of 6 ft.; it

was estimated that a *steam* engine of equal power would have required only a single cylinder, 4 ft. in diameter and of 10-ft. stroke, running at 17 revolutions per minute and using 4 lb. of coal per horse power per hour. The air engine ran at 9 r. p. m., and its great bulk and cost, noisiness and rapid deterioration, overbore the advantage of a much lower fuel consumption, 1.87 lb. of coal per hp.hr. At the present time, with increased

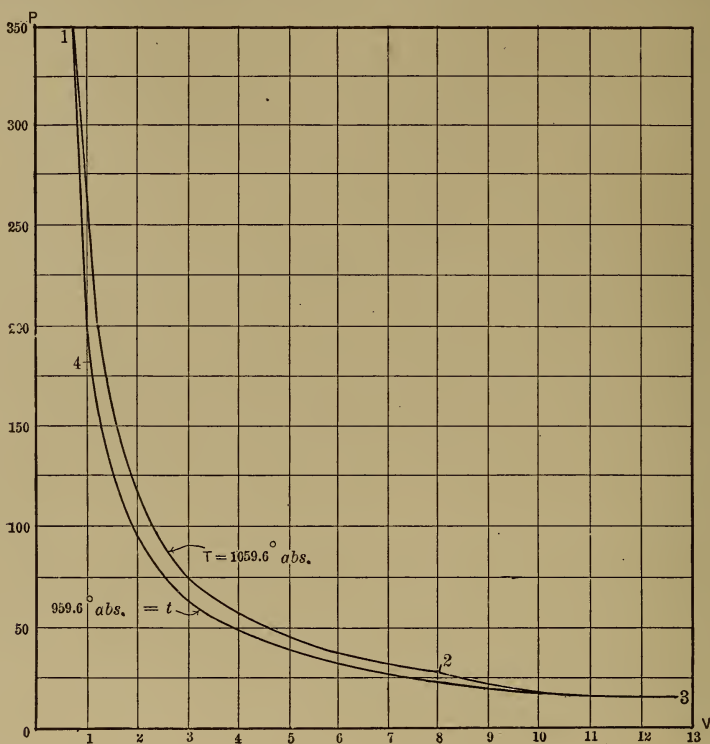

FIG. 94. Arts. 249, 250. — Carnot Cycle for Air.

steam pressures and piston speeds, the equivalent steam engine would be still smaller.

250. Carnot Cycle Air Engine. The efficiency of the cycle shown in Fig. 94 has already been computed as $(T-t) \div T$ (Art. 135). The work done per cycle is, from Art. 135,

$$W = R \left(T \log_e \frac{V_2}{V_1} - t \log_e \frac{V_3}{V_4} \right) = R(T-t) \log_e \frac{V_2}{V_1} = R(T-t) \log_e \frac{V_3}{V_4}.$$

Another expression for the work, since

$$\frac{V_2}{V_1} = \frac{P_1}{P_2}, \text{ is } W = R(T-t) \log_e \frac{P_1}{P_2}.$$

But from Art. 104, $\frac{P_2}{P_3} = \left(\frac{T}{t}\right)^{\frac{y}{y-1}}$, whence

$$P_2 = P_3 \left(\frac{T}{t}\right)^{\frac{y}{y-1}} \text{ and } W = R(T-t) \log_e \frac{P_1}{P_3} \left(\frac{t}{T}\right)^{\frac{y}{y-1}}.$$

This can have a positive value only when $\frac{P_1}{P_3} \left(\frac{t}{T}\right)^{\frac{y}{y-1}}$ exceeds unity; which

is possible only when $\frac{P_1}{P_3}$ exceeds $\left(\frac{T}{t}\right)^{\frac{y}{y-1}}$. Now since P_1 and P_3 are the

limiting pressures in the cycle, and since for air $y \div (y - 1) = 3.486$, the **minimum necessary ratio of pressures increases as the 3.486 power of the ratio of temperatures.*** This alone makes the cycle impracticable. In Fig. 94, the pressure range is from 14.7 to 349.7 lb. per square inch, although the temperature range is only 100°.

Besides the two objections thus pointed out—large size for its capacity and extreme pressure range for its efficiency—the Carnot engine would be distinguished by a high ratio of maximum to average pressure; a condition which would make friction losses excessive.

251. Polytropic Cycle. In Fig. 95, let T, t be two isothermals, eb and df two like polytropic curves, following the law $pv^n = c$, and ed and bf two other like polytropic curves, following the law $pv^m = c$. Then $ebfd$ is a *polytropic cycle*. Let T, t, P_b, P_e

be given. Then $T_e = T \left(\frac{P_e}{P_b}\right)^{\frac{n-1}{n}}$. In the en-

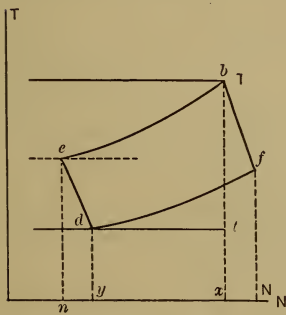

FIG. 96. Arts. 251, 256. — Polytropic Cycle.

trophy diagram, Fig. 96, locate the isothermals T, t, T_e . Choose the point e at random. From Art. 111, the specific heat along a path $pv^n = c$ is $s = l \left(\frac{n-y}{n-1}\right)$; and

from Art. 163, the increase of entropy when the specific heat is s , in passing from e to b , is $N = s \log_e \frac{T_b}{T_e}$. This permits of plotting the curve

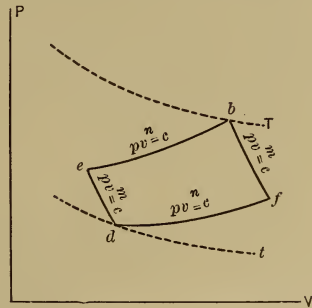

FIG. 95. Arts. 251, 256, Prob. 4a. — Polytropic Cycle.

* It has been shown that $\frac{P_1}{P_4} = \left(\frac{T_1}{T_4}\right)^{\frac{y}{y-1}}$. But $P_3 < P_4$, if a finite work area is to

be obtained; hence $\frac{P_1}{P_3} < \left(\frac{T_1}{T_4}\right)^{\frac{y}{y-1}}$. The efficiency of the Carnot cycle may of course

be written as $1 - \left(\frac{P_4}{P_1}\right)^{\frac{y-1}{y}} = 1 - \left(\frac{V_4}{V_1}\right)^{1-y} = 1 - \left(\frac{V_1}{V_4}\right)^{y-1}$

eb in successive short steps, in Fig. 96. Along *ed*, similarly, $s_1 = l \left(\frac{m-y}{m-1} \right)$ and $N_1 = s_1 \log_e \frac{T_e}{T_d}$ between *d* and *e*. We complete the diagram by drawing *bf* and *df*, establishing the point of intersection which determines the temperature at *f*. We find $T_f : T_b :: T_d : T_e$. The efficiency is equal to $\frac{ebfd}{nebfN}$, or to

$$\begin{aligned} & [nebx + xbfN - ydfN - nedy] \div [nebx + xbfN] \\ &= \frac{s(T_b - T_e) + s_1(T_b - T_f) - s(T_f - T_d) - s_1(T_e - T_d)}{s(T_b - T_e) + s_1(T_b - T_f)} \\ &= 1 - \frac{s(T_f - T_d) + s_1(T_e - T_d)}{s(T_b - T_e) + s_1(T_b - T_f)}, \end{aligned}$$

the negative sign of the specific heat s_1 being disregarded.

252. Lorenz Cycle. In Fig. 97 let *dg* and *bh* be adiabatics, and let the curves *gb* and *dh* be polytropics, but unlike, the former having the exponent *n*, and the latter the exponent *q*. This constitutes the cycle of *Lorenz*. We find the tempera-

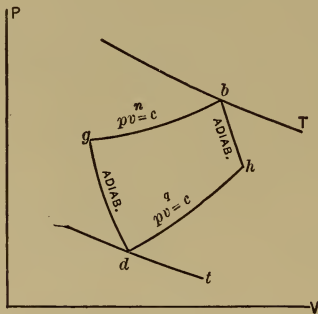

FIG. 97. Arts. 252, 256, Prob. 5.—Lorenz Cycle.

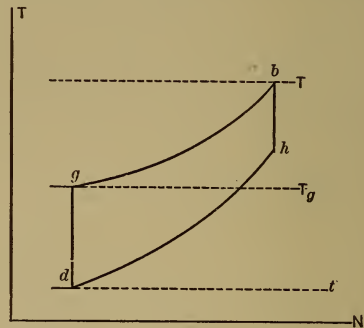

FIG. 98. Arts. 252, 256.—Lorenz Cycle, Entropy Diagram.

ture at *g* as in Art. 251, and in the manner just described plot the curves *gb* and *dh* on the entropy diagram, Fig. 98, P_g, P_b, T_b, T_d, n and q being given. *dg* and *bh* of course appear as vertical straight lines. The efficiency is

$$\frac{s_n(T_b - T_g) - s_q(T_h - T_d)}{s_n(T_b - T_g)}$$

253. Reitlinger Cycle. This appears as *aicj*, Figs. 99 and 100. It is bounded by two isothermals and two like polytropics (isodiabatics). The Carnot is a special example of this type of cycle. To plot the entropy diagram, Fig. 100, we assume the ratio of pressures or of volumes along *ai* or *cj*. Let V_a and V_t be given. Then the gain of entropy from *a* to *i* is $\left(P_a V_a \log_e \frac{V_t}{V_a} \right) \div T$. The curves *ic* and *aj* are

plotted for the given value of the exponent n . This is sometimes called the *isodiabatic cycle*. Its efficiency is

$$(H_{ai} + H_{ic} - H_{jc} - H_{aj}) \div (H_{ai} + H_{ie}),$$

which may be expanded as in Arts. 251, 252.

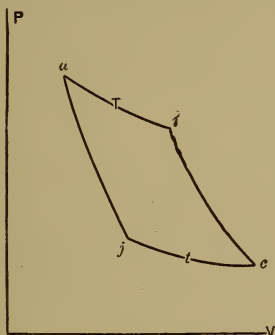

FIG. 99. Arts. 253, 256.—Reitlinger Cycle.

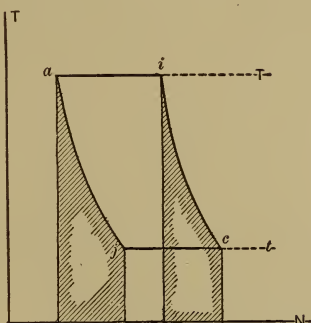

FIG. 100. Arts. 253, 256, 257, 258, 259.—Reitlinger Cycle, Entropy Diagram.

254. Joule Engine. An air engine proposed by Ericsson as early as 1833, and revived by Joule and Kelvin in 1851, is shown in Fig. 101. A chamber C contains air kept at a low temperature t by means of circulating water. Another chamber A contains hot air in a state of compression, the heat being supplied at a constant temperature T by means of an external furnace (not shown). M is a pump cylinder by means of which air

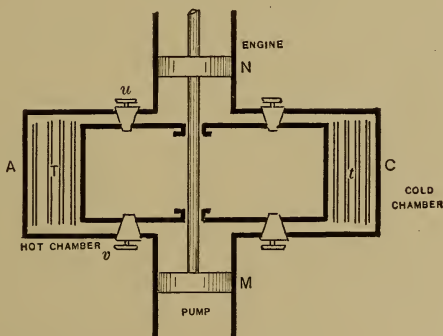

FIG. 101. Arts. 254, 255, 275.—Joule Air Engine.

may be delivered from C to A , and N is an engine cylinder in which air from A may be expanded so as to perform work. The chambers A and C are so large in proportion to M and N that the pressure of the air in these chambers remains practically constant.

The pump M takes air from C , compresses it adiabatically, until its pressure equals that in A , then, the valve v being opened, delivers it to A

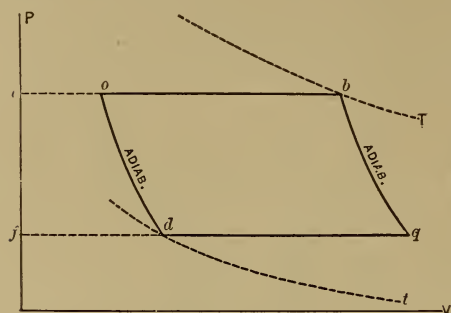

FIG. 102. Arts. 254, 255, 256.—Joule Cycle.

at constant pressure. The cycle is $fdoe$, Fig. 102. In this special modification of the polytropic cycle of Art. 251, fd represents the drawing in of the air at constant pressure, do its adiabatic compression, and oe its discharge to A . Negative work is done, equal to the area $fdoe$. Concurrently with this operation, hot air has been flowing from A to N through the valve u , then expanding

adiabatically while u is closed; finally, when the pressure has fallen to that in C , being discharged to the latter chamber, the cycle being $ebqf$, Fig. 102. Positive work has been done, and the net positive work performed by the whole apparatus is $ebqf - fdoe = obqd$.

255. Efficiency of Joule Engine. We will limit our attention to the net cycle $obqd$. The heat absorbed along the constant pressure line ob is $H_{ob} = k(T - T_o)$. The heat rejected along qd is $H_{qd} = k(T_q - t)$. But from Art. 251, $\frac{T_q}{t} = \frac{T}{T_o}$, whence, $\frac{T_q - t}{T - T_o} = \frac{t}{T_o}$, and the efficiency is

$$\frac{H_{ob} - H_{qd}}{H_{ob}} = 1 - \frac{H_{qd}}{H_{ob}} = 1 - \frac{T_q - t}{T - T_o} = 1 - \frac{t}{T_o} = \frac{T_o - t}{T_o}.$$

This is obviously less than the efficiency of the Carnot cycle between T and t . The entropy diagram may be readily drawn as in Fig. 103. The atmosphere may of course take the place of the cold chamber C , a fresh supply being drawn in by the pump at each stroke, and the engine cylinder likewise discharging its contents to the atmosphere. The ratio $fd + fq$,

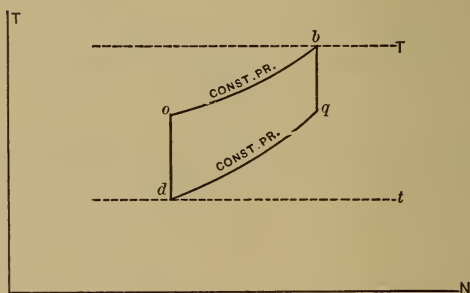
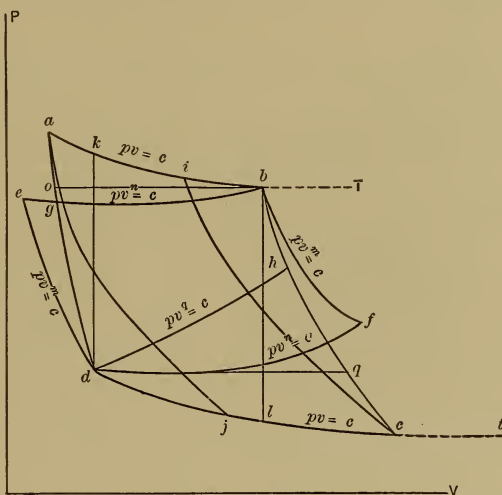

FIG. 103. Arts. 255, 256.—Joule Cycle, Entropy Diagram.

in Fig. 102, shows the necessary ratio of volumes of pump cylinder and engine cylinder. The need of a large pump cylinder would be a serious drawback in practice; it would make the engine bulky and expensive, and

would lead to an excessive amount of mechanical friction. The Joule engine has never been constructed.

256. Comparisons. The cycles just described have been grouped in a single illustration in Fig. 104. Here we have, between the temperature limits T and t , the *Carnot* cycle, $abcd$; the *polytropic* cycle, $debf$; the *Lorenz* cycle, $dgbh$; that of *Reitlinger*, $aicj$; and that of *Joule*, $obqd$. These illustrations are lettered to correspond with Figs. 95-100, 102, 103. A graphical demonstration that the Carnot cycle is the one of maximum efficiency suggests itself. We now consider the most successful attempt yet made to evolve a cycle having a potential efficiency equal to that of Carnot.



257. Regenerators. By reference to Fig. 100, it may be noted that the heat areas under aj and ic are equal. The heat absorbed along the one path is precisely equal to that rejected along the other. This fact does not prevent the efficiency from being less than that of the Carnot cycle, for efficiency is the quotient of work done by the *gross*

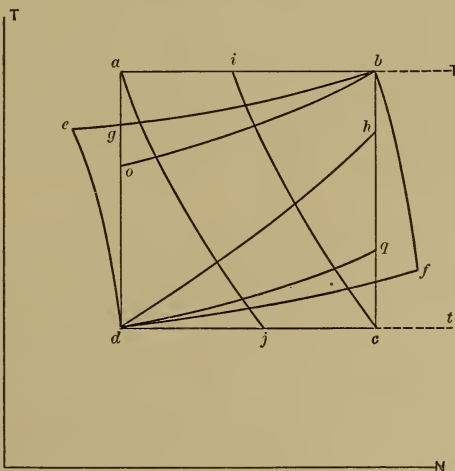

FIG. 104. Arts. 256, 266.—Hot-air Cycles.

heat absorption. If, however, the heat under ic were absorbed *not* from the working substance, and that under ja were rejected

not to the condenser; but if some *intermediate body* existed having a storage capacity for heat, such that the heat rejected to it along ja could be afterward taken up from it along ic , then we might ignore this quantity of heat as affecting the expression for efficiency, and the cycle would be as efficient as that of Carnot. The *intermediate body* suggested is called a **regenerator**.

258. Action of Regenerators. Invented by Robert Stirling about 1816, and improved by James Stirling, Ericsson, and Siemens, the present form of regenerator may be regarded as a long pipe, the walls of which have so large a capacity for heat that the temperature at any point remains practically constant. Through this pipe the air flows in one direction when working along ic , Fig. 100, and in the other direction while working along ja . The air encounters a gradually changing temperature as it traverses the pipe.

Let hot exhaust air, at i , Fig. 100, be delivered at one end of the regenerator. Its temperature begins to fall, and continues falling, so that when it leaves the regenerator its temperature is that at c , usually the temperature of the atmosphere. The temperature at the inlet end of the regenerator is then T , that at its outlet t . During the admission of fresh air, along ja , it passes through the regenerator in the opposite direction, gradually increasing in temperature from t to T , without appreciably affecting the temperature of the regenerator. Assuming the capacity of the regenerator to be unlimited, and that there are no losses by conduction of heat to the atmosphere or along the material of the regenerator itself, the process is strictly *reversible*. We may cause either the volume or the pressure to be either fixed or variable according to some definite law, during the regenerative movement. Usually, either the pressure or the volume is kept *constant*.

As actually constructed, the regenerator consists of a mass of thin perforated metal sheets, so arranged as not to obstruct the flow of air. Some waste of heat always accompanies the regenerative process; in the steamer *Ericsson*, it was 10 per cent of the total heat passing through. Siemens appears to have reduced the loss to 5 per cent.

259. Influence on Efficiency. Any cycle bounded by a pair of isothermals and a pair of like polytropics (Reitlinger cycle), if worked with a regenerator, has an efficiency ideally equal to that of the Carnot cycle. To be sure, the heated air is not all taken in at T , nor all rejected at t ; but the heat absorbed **from the source** is all at T , and that rejected **to the condenser** is all at t . The regenerative operations are mutually compensating changes which do not affect the general principle of efficiency under such conditions. The heat **paid for** is only that under the line ai , Fig. 100. The regenerator thus makes the efficiency of the Carnot cycle obtainable by actual heat engines.

As will appear, the cycles in which a regenerator is commonly employed are not otherwise particularly efficient. Their chief advantage is in the large work area obtained, which means *increased capacity of an engine* of given dimensions. For highest *efficiency*, the regenerator must be added.

260. The Stirling Engine. This important type of regenerative air engine was covered by patents dated 1827 and 1840, by Robert and James Stirling. Its action is illustrated in Fig. 105. *G* is the engine cylinder, containing the piston *H*, and receiving heated air through the pipe *F* from the vessel *AA* in which the air is alternately heated and cooled. The vessel *AA* is made with hollow walls, the inner lining being marked *aa*. The hemispherical lower portion of the lining is perforated; while from *AA* up to *CC* the hollow space constitutes the regenerator, being filled with strips of metal or glass. The plunger *E* fits loosely in the machined inner shell *aa*. This plunger is hollow and filled with some non-conducting material. The spaces *DD* contain the condenser, consisting of a coil of small copper pipe, through which water is circulated by a separate pump. An air pump discharges into the pipe *F* the necessary quantity of fresh air to compensate for any leakage, and this is utilized in some cases to maintain a *pressure* which is at all stages *considerably above that of the atmosphere*. The furnace is built about the bottom *ABA* of the heating vessel.

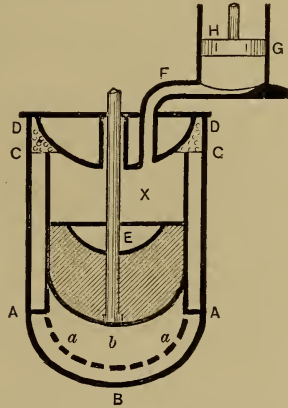

FIG. 105. Arts. 260, 261, 262, 263, 264.—Stirling Engine.

261. Action of the Engine. Let the plunger *E* and the piston *H* be in their lowest positions, the air above *E* being cold. The plunger *E* is raised, causing air to flow from *X* downward through the regenerator to the space *b*, while *H* remains motionless. The air takes up heat from the regenerator, *increasing its temperature*, say to *T*, *while the volume remains constant*. After the plunger has come to rest, the piston *H* is caused to rise by the *expansion* produced by the absorption of heat from the furnace at *constant temperature*, the air reaching *H* by passing around the loose-fitting plunger *E*, which remains stationary. *H* now pauses in its “up” position, while *E* is lowered, forcing air through the regenerator from the lower space *b* to the upper space *X*, this air *decreasing in temperature at constant volume*. While *E* remains in its “down” position, *H* descends, forcing the air to the condenser *D*, the *volume decreasing*, but the *temperature remaining constant at t*. The cycle is thus completed.

The working air has undergone four changes: (*a*) increase of pressure and temperature at constant volume, (*b*) expansion at constant temperature, (*c*) a fall of pressure and temperature at constant volume, and (*d*) compression at constant temperature.

262. Remarks. With action as described, the piston H and the plunger E (sometimes called the "displacer piston") do not move at the same time; one is always nearly stationary, at or near the end of its stroke, while the other moves. In practice, uniform rotative speed is secured by modifying these conditions, so that the actual cycle merely approximates that described. The vessel AA is sometimes referred to as the "receiver." It is obvious that a certain residual quantity of air is at all times contained in the spaces between the piston H and the plunger E . This does not pass through the regenerator, nor is it at any time subjected to the heat of the furnace. It serves merely as a medium for transmitting pressure from the "working air" to H ; and in contradistinction to that working substance, it is called "cushion air." Being at all times in communication with the condenser, its temperature is constantly close to the minimum attained in the cycle. This is an important point in facilitating lubrication.

263. Forms of the Stirling Engine. In some types, a separate pipe is carried from the lower part of the receiver to the working cylinder G , Fig. 105. This removes the necessity for a loose-fitting plunger; in double-acting engines, each end of the cylinder is connected with the hot (lower) side of the one plunger and with the cold (upper) side of the other. In other forms, the regenerator has been a separate vessel; in still others, the displacer plunger itself became the regenerator, being perforated at the top and bottom and filled with wire gauze. The Laubereau-Schwartzkopf engine (1) is identical in principle with the Stirling, excepting that the regenerator is omitted.

The maintenance of high minimum pressure, as described in Art. 260, and the low ratio of maximum to average pressure, while not necessarily affecting the theoretical efficiency, greatly increase the capacity, and (since friction losses are practically constant) the mechanical efficiency as well.

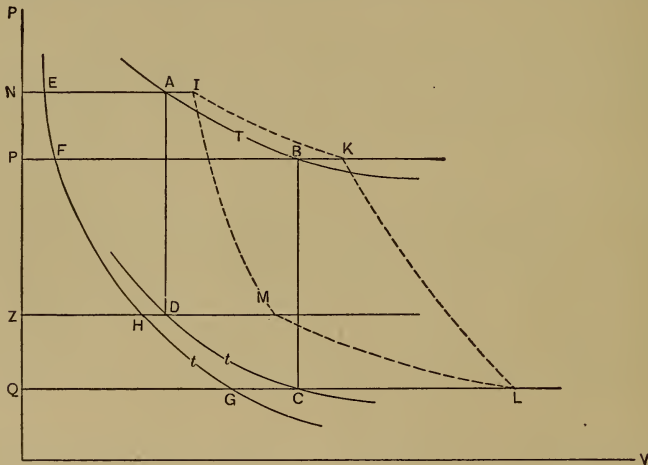

FIG. 106. Arts. 264, 265, 267.—Stirling Cycle.

264. Pressure-Volume Diagram. The cycle of operations described in Art. 261 is that of Fig. 106, $ABCD$. Considering the cushion air, the

actual diagram which would be obtained by measuring the pressures and volumes is quite different. Assume, for example, that the total volume of cushion air at maximum pressure (when *E* is at the top of its stroke and *H* is just beginning to move) is represented by the distance *NE*. Then if *AI* be laid off equal to *NE*, the total volume of air present is *NI*. Draw an isothermal *EFHG*, representing the path of the cushion air, separately considered, while the temperature remains constant. Add its volumes, *PF*, *ZH*, *QG*, to those of working air, by laying off *BK* = *PF*, *DM* = *ZH*, *CL* = *QG*, at various points along the stroke. Then the cycle *IKLM* is that actually experienced by the total air, assuming the cushion air to remain at constant temperature throughout (Art. 262).

The actual indicator diagrams obtained in tests are roughly similar to the cycle *IKLM*, Fig. 106; but the corners are rounded, and other distortions may appear on account of non-conformity with the ideal paths, sluggish valve action, errors of the indicating instrument, and various other causes.

265. Efficiency. The heat absorbed from the source along *AB*, Fig. 106, is $P_A V_A \log_e \frac{V_B}{V_A}$. That rejected to the condenser along *CD* is $P_D V_D \log_e \frac{V_C}{V_D}$. The work done is the difference of these two quantities, and the efficiency is

$$\frac{P_A V_A \log_e \frac{V_B}{V_A} - P_D V_D \log_e \frac{V_C}{V_D}}{P_A V_A \log_e \frac{V_B}{V_A}} = \frac{T - t}{T},$$

that of the Carnot cycle. Losses through the regenerator and by imperfection of cycle reduce this in practice.

266. Entropy Diagram. This is given in Fig. 108. *T* and *t* are the limiting isothermals, *DA* and *BC* the constant volume curves, along each of which the increase of entropy is $n = l \log_e(T \div t)$, *l* being the specific heat at constant volume. The gain of entropy along the isothermals is obtained as in Art. 253. Ignoring the heat areas *EDAF* and *GCBH*, the efficiency is $ABCD \div FABH$, that of the Carnot cycle. The Stirling cycle appears in the *PV* diagram of Fig. 104 as *dkbl*.

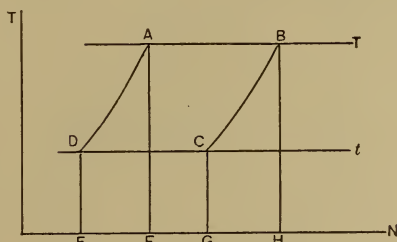

FIG. 108. Art. 266.—Stirling Cycle, Entropy Diagram.

267. Importance of the Regenerator. Without the regenerator, the non-reversible Stirling cycle would have an efficiency of

$$\frac{(P_A - P_D) V_A \log_e \frac{V_B}{V_A}}{l(T-t) + P_A V_A \log_e \frac{V_B}{V_A}}$$

This is readily computed to be far below that of the corresponding Carnot cycle. The advantage of the regenerative cycle lies in the utilization of the heat rejected along *BC*, Fig. 106, thus cancelling that item in the analysis of the cycle. Another way of utilizing this heat is to be described; but while practical difficulties, probably insurmountable, limit progress in the application of the air engine on a commercial scale, the regenerator, upon which has been founded our modern metallurgical industries as well, has offered the first possible method for the realization of the ideal efficiency of Carnot (2).

268. Trials. As early as 1847, a 50-hp. Stirling engine, tested at the Dundee Foundries, was shown to operate at a thermal efficiency of 30 per cent, estimated to be equivalent, considering the rather low furnace efficiency, to a coal consumption of 1.7 lb. per hp.-hr. This latter result is not often surpassed by the average steam engines of the present day. The friction losses in the mechanism were only 11 per cent (3). A test quoted by Peabody (4) gives a coal rate of 1.66 lb., but with a friction loss much greater,—about 30 per cent. There is no question as to the high efficiency of the regenerative air engine.

269. Ericsson's Hot-air Engine. In 1833, Ericsson constructed an unsuccessful hot-air engine in London. About 1855, he built the steamer *Ericsson*, of 2200 tons, driven by four immense hot-air engines. After the abandonment of this experiment, the same designer in 1875 introduced a third type of engine, and more recently still, a small pumping engine, which has been extensively applied.

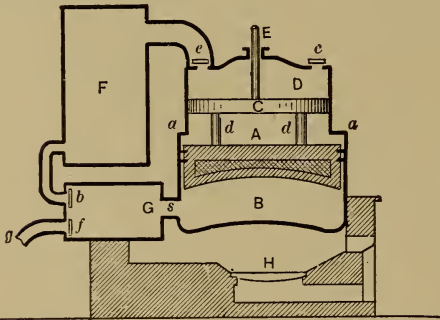

FIG. 109. Arts. 269, 270, 275.—Ericsson Engine.

The principle of the engine of 1855 is illustrated in Fig. 109. *B* is the receiver, *A* the displacer, *H* the furnace. The displacer *A* fits loosely in *B* excepting near its upper portion, where tight contact is insured by means of packing rings. The lower portion of *A* is hollow, and filled with a non-conductor. The holes *aa* admit air to the upper surface of *A*. *D* is the compressing pump, with piston *C*, which is connected with *A* by the rods *dd*. *E* is a piston rod through which the developed power is externally applied. Air enters the space above *C* through the check valve *c*, and is compressed during the up stroke into the magazine *F*

through the second check valve *e*. *G* is the regenerator, made up of wire gauze. The control valves, worked from the engine mechanism, are at *b* and *f*. When *b* is opened, air passes from *F* through *G* to *B*, raising *A*. Closing of *b* at part completion of the stroke causes the air to work expansively for the remainder of the stroke. During the return stroke of *A*, air passes through *G*, *f*, and *g* to the atmosphere.

270. Graphical Illustration. The *PV* diagram is given in Fig. 110. *EBCF* is the net work diagram, *ABCD* being the diagram of the engine cylinder, *AEFD* that of the pump cylinder. Beginning with *A* in its lowest position, the state point in Fig. 110 is, for the engine (lower side of *A*), at *A*, and for the pump (upper side of *C*), at *F*. During about half the up stroke, the path in the engine is *AB*, air passing to *B* from the regenerator through *s*, and being kept at constant pressure by the heat from the furnace. During the second half of this stroke, the supply of air from the regenerator ceases, and the pressure falls rapidly as expansion occurs, but the heat imparted from the furnace keeps the temperature practically constant, giving the isothermal path *BC*. Meanwhile, the pump, receiving air at the pressure of the atmosphere, has been first compressing it isothermally, or as nearly so as the limited amount of cooling surface will permit, along *FE*, and then discharging it through *e* at constant pressure, along *EA*, to the receiver *F*. On the down stroke, the engine steadily expels the air, now expanded down to atmospheric pressure, along the constant pressure line *CD*, while the pump similarly draws in air from the atmosphere at constant pressure along *DF*. At the end of this stroke, the air in *F*, at the state *A*, is admitted to the engine. The ratio of pump volume to engine volume is $FD \div DC$, or $\frac{t}{T}$.

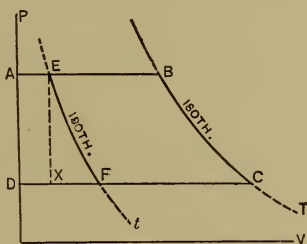

FIG. 110. Arts. 270, 272, 273.—Ericsson Cycle.

271. Efficiency. The Ericsson cycle belongs to the same class as that of Stirling, being bounded by two isothermals and two like polytropics; but the polytropics are in this case constant pressure lines instead of constant volume lines. The net entropy diagram *EBCF*, Fig. 111, is similar to that of the Stirling engine, but the isodiabatics swerve more to the right, since *k* exceeds *l*, while the efficiency (if a regenerator is employed) is the same as that of the Stirling engine, $\frac{T-t}{T}$.

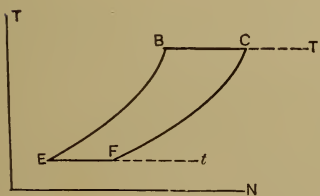

FIG. 111. Art. 271.—Ericsson Cycle, Entropy Diagram.

272. Tests. As computed by Rankine from Norton's tests, the efficiency of the steamer *Ericsson's* engines was 26.3 per cent; the efficiency of the furnace was, however, only 40 per cent. The average effective pres-

sure ($EBCF \div XC$, Fig. 110) was only 2.12 lb. The friction losses were enormous. A small engine of this type tested by the writer gave a consumption of 15.64 cu. ft. of gas (652 B. t. u. per cubic foot) per Ihp.-hr.; equivalent to 170 B. t. u. per Ihp.-minute; and since 1 horse power = 33,000 foot-pounds = $33,000 \div 778 = 42.45$ B. t. u. per minute, the thermodynamic efficiency of the engine was $42.45 \div 170 = 0.25$.

273. Actual Designs. In order that the lines FC and EB , Fig. 110, may be horizontal, the engine should be **triple** or **quadruple**, as in the steamer *Ericsson*, in which each of the four cylinders had its own compressing pump, but all were connected with the same receiver, and with a single crank shaft at intervals of a quarter of a revolution. Specimen indicator diagrams are given in Figs. 107, 112.



FIG. 107. Art. 273.—Indicator Card from Ericsson Engine.



FIG. 112. Art. 273.—Indicator Diagram, Ericsson Engine.

274. Testing Hot-air Engines. It is difficult to directly and accurately measure the limiting temperatures in an air engine test, so that a comparison of the actually attained with the computed ideal efficiencies cannot ordinarily be made. Actual tests involve the measurement of the fuel supplied, determination of its heating value, and of the indicated and effective horse power of the engine (Art. 487). These data permit of computation of the thermal and mechanical efficiencies, the latter being of much importance. In small units, it is sometimes as low as 0.50.

275. The Air Engine as a Heat Motor. In nearly every large application, the hot-air engine has been abandoned on account of the rapid burning out of the heating surfaces due to their necessarily high temperature. Napier and Rankine (5) proposed an "air heater," designed to increase the transmissive efficiency of the heating surface. Modern forms of the Stirling or Ericsson engines, in *small units*, are comparatively free from this ground of objection. Their design permits of such amounts of heat-transmitting surface as to give grounds for expecting a much less rapid destruction of these parts. It has been suggested that excessive bulk may be overcome by using higher pressures. (Zeuner remarks (6) that the bulk is not excessive when compared with that of a steam engine with its auxiliary boiler and furnace). Rankine has suggested the introduction of a second compressed air receiver, in Fig. 109, from which the supply of air would be drawn through c , and to which air would be discharged through f . This would make the engine a "closed" engine, in which the minimum pressure could be kept fairly high; a small air pump would be required to compensate for leakage. A "condenser" would be needed to supplement the action of the regenerator by more

thoroughly cooling the discharged air, else the introduction of "back pressure" would reduce the working range of temperatures. The loss of the air by leakage, and consequent waste of power, would of course increase with increasing pressures.

Instead of applying heat externally, as proposed by Joule, in the engine shown in Fig. 101, there is no reason why the combustion of the fuel might not proceed within the hot chamber itself, the necessary air for combustion being supplied by the pump. The difficulties arising from the slow transmission of heat would thus be avoided. An early example of such an engine applied in actual practice was Cayley's (7), later revived by Wenham (8) and Buckett (9). In such engines, the working fluid, upon the completion of its cycle, is discharged to the atmosphere. The lower limit of pressure is therefore somewhat high, and for efficiency the necessary wide range of temperatures involves a high initial pressure in the cylinder. The internal combustion air engine even in these crude forms may be regarded as the forerunner of the modern gas engine.

(1) Zeuner, *Technical Thermodynamics* (Klein), 1907, I, 340. (2) The theoretical basis of regenerator design appears to have been treated solely by Zeuner, *op. cit.*, I, 314-323. (3) Rankine, *The Steam Engine*, 1897, 368. (4) *Thermodynamics of the Steam Engine*, 1907, 302. (5) *The Steam Engine*, 1897, 370. (6) *Op. cit.*, I, 381. (7) *Nicholson's Art Journal*, 1807; *Min. Proc. Inst. C. E.*, IX. (8) *Proc. Inst. Mech. Eng.*, 1873. (9) *Inst. Civ. Eng.*, Heat Lectures, 1883-1884; *Min. Proc. Inst. C. E.*, 1845, 1854.

SYNOPSIS OF CHAPTER X

The hot-air engine proper is an *external* combustion motor of the *open* or *closed* type. The temperature of a permanent gas may be varied independently of the pressure; this makes the possible efficiency higher than that attainable in vapor engines.

$\left(\frac{P}{p}\right) = \left(\frac{T}{t}\right)^{3.486}$; the *Carnot* cycle leads to either excessive pressures or an enormous cylinder.

The *polytropic* cycle is bounded by two pairs of isodiabatics.

The *Lorenz* cycle is bounded by a pair of adiabatics and a pair of unlike polytropics.

The *Reitlinger* (isodiabatic) cycle is bounded by a pair of isothermals and a pair of isodiabatics.

The *Joule* engine works in a cycle bounded by two constant pressure lines and two adiabatics; its efficiency is $\frac{T_o - t}{T_o}$.

The *regenerator* is a "fly wheel for heat." Any cycle bounded by a pair of isothermals and a pair of like polytropics, if worked with a regenerator, has an ideal efficiency *equal to that of the Carnot cycle*; the heat rejected along one polytropic is absorbed by the regenerator, which in turn emits it along the other polytropic, the operation being subject to slight losses in practice.

The *Stirling* cycle, bounded by a pair of isothermals and a pair of constant volume curves: correction of the ideal *PV* diagram for cushion air: comparison with indicator card; the entropy diagram; efficiency formulas with and without the regenerator; coal consumption, 1.7 lb. per hp.-hr.

The *Ericsson* cycle, bounded by a pair of isothermals and a pair of constant pressure curves; efficiency from fuel to power, 26 per cent.

By designing as "closed" engines, the minimum pressure may be raised and the capacity of the cylinder increased.

The air engine is unsatisfactory in large sizes on account of the rapid burning out of the heating surfaces and the small capacity for a given bulk.

PROBLEMS

(NOTE. Considerable accuracy in computation will be found necessary in solving Problems 4 *a* and 5).

1. How much greater is the ideal efficiency of an air engine working between temperature limits of 2900° F. and 600° F. than that of the steam engine described in Problem 5, Chapter VI?

2. Plot to scale (1 inch = 2 cu. ft. = 40 lb. per square inch) the *PV* Carnot cycle for $T = 600^\circ$, $t = 500^\circ$ (both absolute) the lowest pressure being 14.7 lb. per square inch, the substance being one pound of air, and the volume ratio during isothermal expansion being 12.6.

3. In Problem 2, if the upper isothermal be made 700° absolute, what will be the maximum pressure?

4 *a*. Plot the entropy diagram, and find the efficiency, of a polytropic cycle for air between 600° F. and 500° F., in which $m = 1.3$, $n = -1.3$, the pressure at *d* (Fig. 95) is 18 lb. per square inch, and the pressure at *e* (Fig. 95) is 22 lb. per square inch.

4 *b*. In Art. 251, prove that $T_f : T_b :: T_d : T_e$, and also that $P_d : P_e :: P_f : P_b$.

5. Plot the entropy diagram, and find the efficiency, of a Lorenz cycle for air between 600° F. and 500° F., in which $n = -1.3$, $q = 0.4$, the highest pressure being 80 lb. per square inch and the temperature at *g*, Fig. 97, being 550° F.

6. Plot the entropy diagram, and find the efficiency, of a Reitlinger cycle between 600° F. and 500° F., when $n = 1.3$, the maximum pressure is 80 lb. per square inch, the ratio of volumes during isothermal expansion 12, and the working substance one pound of air.

7. Show that in the Joule engine the efficiency is $\frac{T - T_g}{T}$, Art. 255.

8. Plot the entropy diagram, and find the efficiency, of a Joule air engine working between 600° F. and -200° F., the maximum pressure being 100 lb. per square inch, the ratio of volumes during adiabatic expansion 2, and the weight of substance 2 lb.

9. Plot *PV* and *NT* diagrams for one pound of air worked between 3000° F. and 400° F.: (*a*) in the Carnot cycle, (*b*) in the Ericsson cycle, (*c*) in the Stirling cycle, the extreme pressure range being from 50 to 2000 lb. per square inch.

10. Find the efficiencies of the various cycles in Problem 9, without regenerators.

11. Compare the efficiencies in Problems 4 *a*, 5, and 6, with that of the corresponding Carnot cycle.

12. An air engine cylinder working in the Stirling cycle between 1000° F. and 2000° F., with a regenerator, has a volume of 1 cu. ft. The ratio of expansion is 3. By what percentages will the capacity and efficiency be affected if the lower limit of pressure is raised from 14.7 to 85 lb. per square inch?

13. In the preceding problem, one eighth of the cylinder contents is cushion air, at 1000° F. Plot the ideal indicator diagram for the lower of the two pressure limits, corrected for cushion air.

14. In Art. 268, assuming that the coal used in the Dundee foundries contained 14,000 B. t. u. per pound, what was the probable furnace efficiency? In the Peabody test, if the furnace efficiency was 80 per cent, and the coal contained 14,000 B. t. u., what was the thermal efficiency of the engine?

15. What was the efficiency of the *plant* in the steamer Ericsson?

16. Sketch the TN and PV diagrams, within the same temperature and entropy limits, of all of the cycles discussed in this chapter, with the exception of that of Joule. Why cannot the Joule and Ericsson cycles be drawn between the same limits? Show graphically that in no case does the efficiency equal that of the Carnot cycle.

17. Compare the cycle areas in Problem 9.

18. In Problem 2, what is the minimum possible range of pressures compatible with a finite work area? Illustrate graphically.

19. Derive a definite formula for the efficiency of the Reitlinger cycle, Art. 253.

20. Derive an expression for the efficiency of the Ericsson cycle without a regenerator.

CHAPTER XI

GAS POWER

THE GAS PRODUCER

276. History. The bibliography (1) of internal combustion engines is extensive, although their commercial development is of recent date. Coal gas was distilled as early as 1691; the waste gases from blast furnaces were first used for heating in 1809. The first English patent for a gas engine approaching modern form was granted in 1794. The advantage of compression was suggested as early as 1801, but was not made the subject of patent until 1838 in England and 1861 in France. Lenoir, in 1860, built the first practical gas engine, which developed a thermal efficiency of 0.04. The now familiar polytropic "Otto" cycle was proposed by Beau de Rochas at about this date. The same inventor called attention to the necessity of high compression pressures in 1862; a principle applied in practice by Otto in 1874. Meanwhile, in 1870, the first oil engine had been built. The four-cycle compressive Otto, "silent" engine was brought out in 1876, showing a thermal efficiency of 0.15, a result better than that then obtained in the best steam power plants.

If the isothermal, isometric, isopiestic, and adiabatic paths alone are considered, there are possible at least twenty-six different gas engine cycles (2). Only four of these have had extended development; of these four, only two have survived. The Lenoir (3) and Hugon (4) non-compressive engines are now represented only by the Bischoff (5). The Barsanti "free piston" engine, although copied by Gilles and by Otto and Langen (1866) (6), is wholly obsolete. The variable volume engine of Atkinson (7) was commercially unsuccessful.

Up to 1885, illuminating gas was commonly employed, only small engines were constructed, and the high cost of the gas prevented them from being commercially economical. Nevertheless, six forms were exhibited in 1887. The Priestman oil engine was built in 1888. With the advent of the Dowson process, in 1878, with its possibilities of cheap gas, advancement became rapid. By 1897, a 400-hp. four-cylinder engine was in use on gas made from anthracite coal. At the present time, double-acting engines of 5400 hp. have been placed in operation; still larger units have been designed, and a few applications of gas power have been made even in marine service.

Natural gas is now transmitted to a distance of 200 miles, under 300 lb. pressure. Illuminating gas has been pumped 52 miles. Martin (8) has computed that coal gas might be transmitted from the British coal fields to London at a delivered cost of 15 cents per 1000 cu. ft. His plan calls for a 25-inch pipe line, at 500 lb. initial pressure and 250 lb. terminal pressure, carrying 40,000,000,000 cu. ft. of

gas per year. The estimated 46,000 hp. required for compression would be derived from the waste heat of the gas leaving the retorts.

Producer gas is even more applicable to heating operations than for power production. It is meeting with extended use in ceramic kilns and for ore roasting, and occasionally even for firing steam boilers.

277. The Gas Engine Method. The expression for ideal efficiency, $(T - t) \div T$, increases as T increases. In a steam plant, although boiler furnace temperatures of 2500° F. or higher are common, the steam passes to the engine, ordinarily, at not over 350° F. This temperature expressed in absolute degrees limits steam engine efficiency. To increase the value of T , either very high pressure or superheat is necessary, and the practicable amount of increase is limited by considerations of mechanical fitness to withstand the imposed pressures or temperatures. In the internal combustion engine, the working substance reaches a temperature approximating 3000° F. in the cylinder. The gas engine has therefore the same advantage as the hot air engine, — a wide range of temperature. Its working substance is, in fact, for the most part heated *air*. The fuel, which may be gaseous, liquid, or even solid, is injected with a proper amount of air, and combustion occurs within the cylinder. The disadvantage of the ordinary hot air engine has been shown to arise from the difficulty of transmitting heat from the furnace to the working substance. In this respect, the gas engine has the same advantage as the steam engine, — large capacity for its bulk, — for there is no transmission of heat; the cylinder is the furnace, and the products of combustion constitute the working substance. A high temperature of working substance is thus possible, with large work areas on the pv diagram, and a rapid rate of heat propagation.

In the gas engine, then, certain chemical changes which constitute the process described as *combustion*, must be considered; although such changes are in general not to be included in the phenomena of engineering thermodynamics.

278. Fuels. (See Arts. 561, 561a.) The common fuels are gases or oils. In some sections, **natural gas** is available. This is high in heating value, consisting mainly of methane, CH_4 . **Carbureted water gas**, used for illumination, is nearly as high in heating value, consisting of approximately equal volumes of hydrogen, carbon monoxide, and methane, with some methylene and traces of other substances. **Uncarbureted (blue) water gas** is almost wholly carbon monoxide and hydrogen. Its heating value is less than half that of the carbureted gas. Both water gas and coal gas are uneconomical for power production; in the processes of manufacture, large quantities of coal are left behind as coke. **Coal gas**, consisting principally of hydrogen and methane, is slightly lower in heating value than carbureted water gas. It is made by distilling soft coal in retorts, about two thirds of the weight of coal becoming coke. **Coke oven gas** is practically the same product; the main output in its case being coke, while in the former it is gas.

Producer gas ("Dowson" gas, "Mond" gas, etc.) is formed by the

partial combustion of coal, crude oil, peat or other material, in air. It is essentially carbon monoxide; diluted with large quantities of nitrogen and consequently low in heating value. Its exact composition varies according to the fuel from which it is made, the quantity of air supplied, etc. When soft coal is used, or when much steam is fed to the producer, large proportions of hydrogen are present.

It is of no value as an illuminant. **Blast furnace gas** is producer gas obtained as a by-product on a large scale in metallurgical operations. It contains less hydrogen than ordinary producer gases, since steam is not employed in its manufacture, and is generally quite variable in its composition on account of the exigencies of furnace operation. **Acetylene**, C_2H_2 , is made by combining calcium carbide and water. It has an extremely high heating and illuminating value. All hydrocarbonaceous substances may be gasified by heating in closed vessels; gases have in this way been produced from peat, sawdust, tan bark, wood, garbage, animal fats, etc.

279. Oil Gases. Many liquid hydrocarbons may be vaporized by appropriate methods, under conditions which make them available for gas engine use. Some of these liquids must be vaporized by artificial heat and then immediately used, or they will again liquefy as their temperatures fall. The vaporizer or "carburetor" is therefore located at the engine, where it atomizes each charge of fuel as required. Gasoline is most commonly used; its vapor has a high heating value. Kerosene, and, more recently, alcohol, have been employed. By mixing gasoline and air in suitable proportions, a saturated or "carbureted" air is produced. This acts as a true gas, and must be mixed with more air to permit of combustion. A gas formed in the proportion of 1000 cu. ft. of air to 2 gallons of liquid gasoline, for example, does not liquefy. A third form of oil gas is produced by heating certain hydrocarbons without air; the "cracking" process produces, first, less dense liquids, and, finally, gaseous bodies, which do not condense. The process must be carried on in a closed retort, and arrangements must be made for the removal of residual tar and coke.

280. Liquid Fuels. These have advantages over solid or gaseous fuels, arising from the usually large heating value per unit of bulk, and from ease of transportation. All animal and vegetable oils and fats may be reduced to liquid fuels; those oils most commonly employed, however, are petroleum products. Crude petroleum may be used; it is more customary to transform this to "fuel oil" by removing the moisture, sulphur, and sediment; and some of these "fuel oils" are used in gas engines. Of petroleum distillates, the gasolines are most commonly utilized in this country. They include an 86° liquid, too dangerous for commercial purposes; the 74° "benzine," and the 69° naphtha. "Distillate," an impure kerosene, from which the gasoline has not been removed, is occasionally used. Both grain alcohol (C_2H_6O) and wood alcohol (CH_4O) have been used in gas engines (9). Various distillates from brown and hard coal tars have been employed in Germany. Their suitability for power purposes varies with different types of engines. The benzol derived from coal gas tar has been successfully used; the brown coal series, C_nH_{2n} , C_nH_{2n+2} , C_nH_{2n-2} , contains many useful members (10).

281. The Gas Producer. This essential auxiliary of the modern gas engine is made in a large number of types, one of which is shown in Fig. 113. This is a brick-lined cylindrical shell, set over a water-sealed pit *P*, on which the ash bed rests. Air is forced in by means of the steam jet blower *A*, being distributed by means of the conical hood *B*, from which

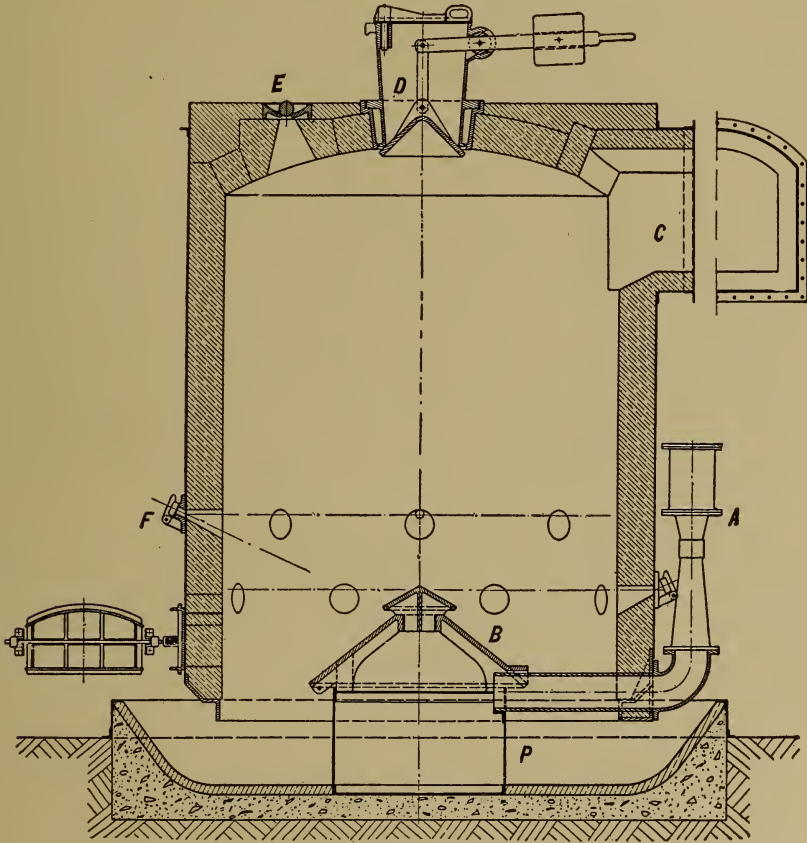

FIG. 113. Art. 281.—The Amsler Gas Producer.

it passes up to the red-hot coal bed above. Here carbon dioxide is formed and the steam decomposes into hydrogen and oxygen. Above this "combustion zone" extends a layer of coal less highly heated. The carbon dioxide, passing upward, is decomposed to carbon monoxide and oxygen. The hot mixed gases now pass through the freshly fired coal at the top of the producer, causing the volatile hydrocarbons to distill off, the entire product passing out at *C*. The coal is fed in through the sealed hopper *D*.

At *E* are openings for the bars used to agitate the fire. At *F* are peep-holes.

An automatic feeding device is sometimes used at *D*. The air may be forced in by a blower, or sucked through by an exhauster, or by the engine piston itself, displacing the steam jet blower *A*. The fuel may be supported on a solid grate, or on the bottom of a producer without the water seal; grates may be either stationary or mechanically operated. Mechanical agitation may be employed instead of the poker bars inserted through *E*. Sometimes water gas, for illumination, and producer gas, for power, are made in the same plant. Two producers are then employed, the air blast being applied to one, while steam is decomposed in the other.

Provision must be made for purifying the gas, by deflectors, wet and dry scrubbers, filters, coolers, etc. For the removal of tar, which would be seriously objectionable in engines, mechanical separation and washing are useful, but the complete destruction of this substance involves the passing of the gas through a highly heated chamber; this may be a portion of the producer itself, as in "under-feed," "inverted combustion," or "down-draft" types: causing the transformation of the tar to fixed gases. On account of the difficulty of tar removal, anthracite coal or coke or semi-bituminous, non-caking coal must generally be used in power plants. The air supplied to the producer is sometimes preheated by the sensible heat of the waste gases, in a "recuperator." The "regenerative" principle — heating the air and gas delivered to the engine by means of the heat of the exhaust gases — is inapplicable, for reasons which will appear.

282. The Producer Plant. The ordinary producer operates under a slight pressure; in the suction type, now common in small plants, the engine piston draws air through the producer in accordance with the load requirements. Pressure producers have been used on extremely low grade fuels: Jahn, in Germany, has, it is reported, gasified mine waste containing only 20 per cent of coal. Suction producers, requiring much less care and attention, are usually employed only on the better grades of fuel. Most producers require a steam blast; the steam must be supplied by a boiler or "vaporizer," which in many instances is built as a part of the producer, the superheated steam being generated by the sensible heat carried away in the gas. Automatic operation is effected in various ways: in the Amsler system, by changing the proportion of hydrogen in the gas, involving control of the steam supply; in the Pintsch process, by varying the draft at the producer by means of an inverted bell, under the control of a spring, from beneath which the engine draws its supply; and in the Wile apparatus, by varying the draft by means of valves operated from the holder. Figure 114 shows a complete producer plant, with separate vaporizer, economizer (recuperator), and holder for storing the gas and equalizing the pressure.

283. By-product Recovery. Coal contains from 0.5 to 3 per cent of nitrogen, about 15 per cent of which passes off in the gas as ammonia. The successful development of the Mond process has demonstrated the possibility of recovering this in the form of ammonium sulphate, a valuable fertilizing agent.

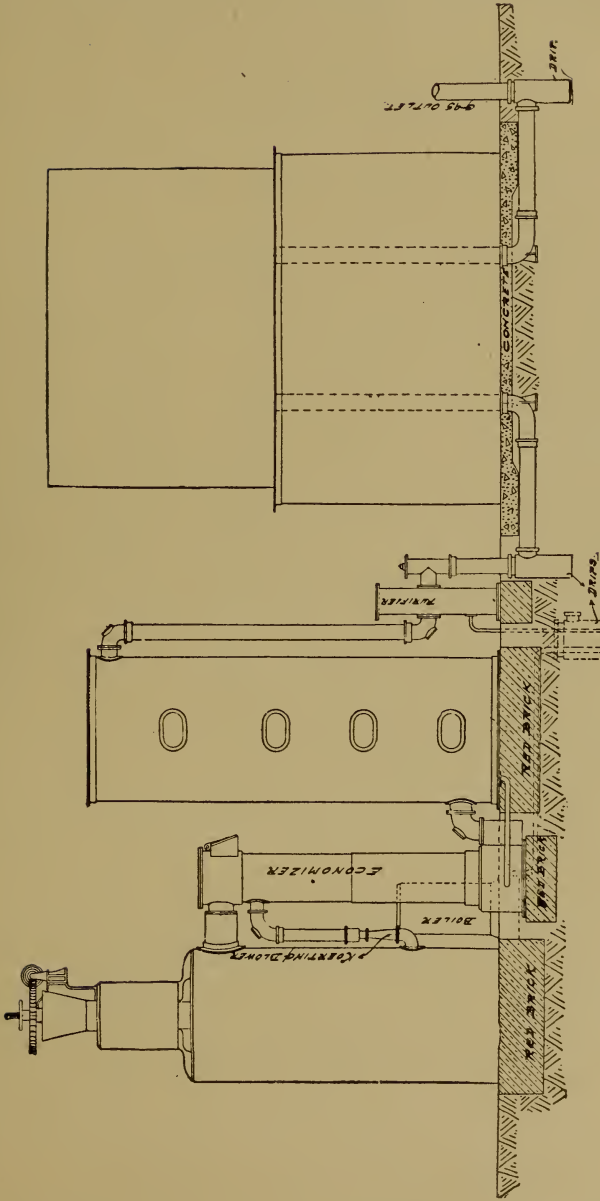

FIG. 114. Art. 282. — Standard Gas Producer Plant for Anthracite or Coke. (E. D. Wood & Co.)

284. Action in the Producer. Coal is gasified on the producer grate. In suction producers, the rate of gasification may be anywhere between 8 and 50 lb. per sq. ft. of grate per hour. Anthracite producers are in this country sold at a rating of 10 to 15 lb. Ideally, the coal is carbon, and leaves the producer as carbon monoxide, 4450 B. t. u. per pound of carbon having been expended in gasification. Then only 10,050 B. t. u. per pound of carbon are present in the gas, and the efficiency cannot exceed $10,050 \div 14,500 = 0.694$. The 4450 B. t. u. consumed in gasification are evidenced only in the temperature of the gas. With actual conditions, the presence of carbon dioxide or of free oxygen is an evidence of improper operation, further decreasing the efficiency. By introducing steam, however, *decomposition* occurs in the producer, the temperature of the gas is reduced, and available hydrogen is carried to the engine; and this action is essential to producer efficiency for power purposes, since a high temperature of inlet gas is a detriment rather than a benefit in engine operation. The ideal efficiency of the producer may thus be brought up to something over 80 per cent; a limit arising when the proportion of steam introduced is such as to reduce the temperature of the gas below about 1800° F., when the rate of decomposition greatly decreases. The proportion of steam to air, by weight, is then about 6 per cent, the heating value of the gas is increased, the percentage of nitrogen decreased, and nearly 20 per cent of the total oxygen delivered to the producer has been supplied by decomposed steam. A similar result may be attained by introducing exhausted gas from the engine to the producer. The carbon dioxide in this gas decomposes to monoxide, which is carried to the engine for further use. This method is practiced in the Mond system, and has had other applications. To such extent as the coal is hydrocarbonaceous, however, the ideal efficiency, irrespective of the use of either steam or waste gas, is 100 per cent. Figure 115 shows graphically the results computed as following the use of either steam or waste gases with pure carbon as the fuel. The maximum ideal efficiency is about $3\frac{1}{2}$ per cent greater when steam is used, if the temperature limit is fixed at 1800° F., but the waste gases give a more uniform (though less rich) gas. The higher initial temperature of the waste gases puts their use practically on a parity with that of steam. Either system tends to prevent clinkering. The maximum of producer efficiency, for power gas purposes, is ideally from 5 to 10 per cent less than that of the steam boiler. High percentages of hydrogen resulting from the excessive use of steam may render the gas too explosive for safe use in an engine (10 a) (25).

285. Example of Computation. Let 20 per cent of the oxygen necessary for gasifying pure carbon be supplied by steam. Each pound of fuel requires $1\frac{1}{2}$ lb. of oxygen for conversion to carbon monoxide. Of this amount, $0.20 \times 1\frac{1}{2} = 0.2666$ lb. will then be supplied by steam; and the balance, 1.0667 lb., will be derived from

the air, bringing in with it $\frac{77}{23} \times 1.0667 = 3.57$ lb. of nitrogen. The oxygen derived from steam will also carry with it $\frac{1}{8} \times 0.2666 = 0.0333$ lb. of hydrogen. The produced gas will contain, per pound of carbon,

- 2.33 lb. carbon monoxide,
- 3.57 lb. nitrogen,
- 0.0333 lb. hydrogen.

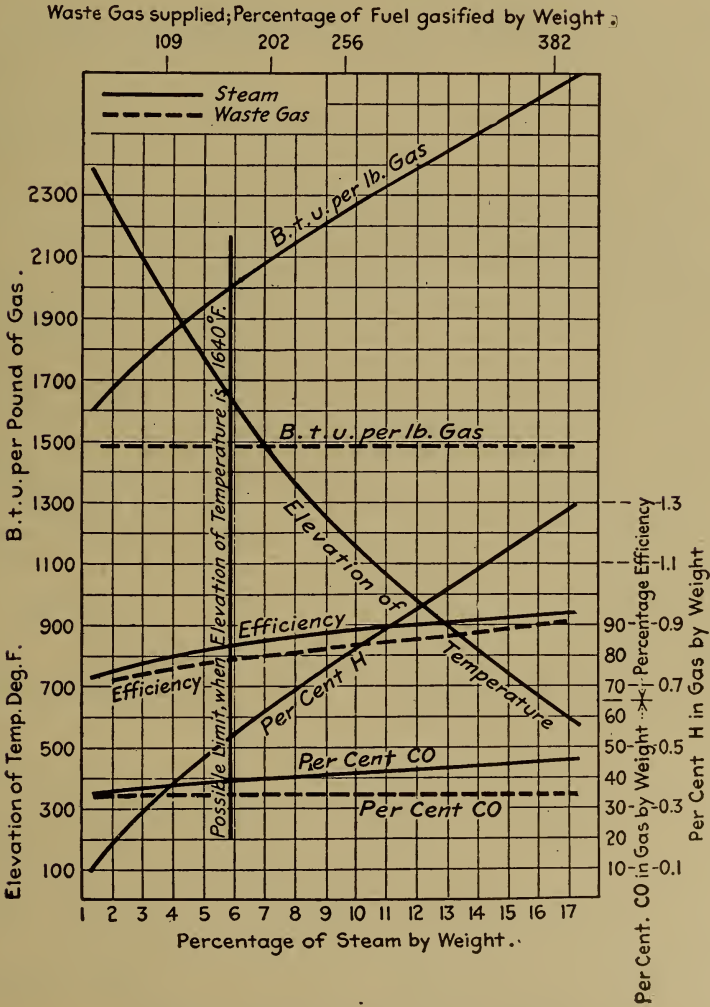

FIG. 115. Art. 284.—Reactions in the Producer.

The heat evolved in burning to monoxide is 4450 B. t. u. per pound. A portion of this, however, has been put back into the gas, the temperature having been lowered by the decomposition of the steam. Under the conditions existing in the

producer, the heat of decomposition is about 62,000 B. t. u. per pound of hydrogen. The net amount of heat evolved is then $4450 - (0.0333 \times 62,000) = 2383$ B. t. u., and the efficiency is $\frac{14,500 - 2383}{14,500} = 0.84$. The rise in temperature is computed as follows: to heat the gas 1° F. there are required

	WEIGHT	×	SPECIFIC HEAT	
For carbon monoxide,	2.33	×	0.2479	= 0.578 B. t. u.
For nitrogen,	3.57	×	0.2438	= 0.869 B. t. u.
For hydrogen,	0.0333	×	3.4	= 0.113 B. t. u.
			a total of	<u>1.560 B. t. u.</u>

The 2383 B. t. u. evolved will then cause an elevation of temperature of $\frac{2383}{1.560} = 1527^\circ$ F.

With pure air only, used for gasifying pure carbon, the gas would consist of $2\frac{1}{2}$ lb. of carbon monoxide and 4.45 lb. of nitrogen; the percentages being 34.5 and 65.5. For an actual coal, the ideal gas composition may be calculated on the assumptions that the hydrogen and hydrocarbons pass off unchanged, and that the carbon requires $1\frac{1}{3}$ times its own weight of oxygen, part of which is contained in the fuel, and part derived from steam or from the atmosphere, carrying with it hydrogen or nitrogen. Multiplying the weight of each constituent gas in a pound by its calorific value, we have the heating value of the gas. As a mean of 54 analyses, Fernald finds (11) the following percentages *by volume*:

Carbon monoxide (CO)	19.2
Carbon dioxide (CO ₂)	9.5
Hydrogen (H)	12.4
Marsh gas and ethylene (CH ₄ , C ₂ H ₄)	3.1
Nitrogen (N)	<u>55.8</u>
	100.0

285 a. Practical Study of Producer Reactions. This subject has presented unexpected complications. Tests made by Allcut at the University of Birmingham (*Power*, July 18, 1911, page 99) call attention to three characteristic processes:



Of these, (A) takes place at temperatures above 1832° , is endothermic, and results in the absorption of 4300 B. t. u. per pound of carbon. The corresponding figure for reaction (B), also endothermic, which occurs at temperatures below 1112° , is 2820 B. t. u. The former of the two is the reaction desired, and is facilitated by high temperatures. The operation (C) is chemically reversible; taking place as stated at temperatures above 932° , but gradually reversing to the opposite (and preferred) transformation when the temperature reaches 1832° .

The tests show that increasing proportions of CO₂ may be associated with increasing proportions of steam introduced. The maximum decomposition reached was 0.535 lb. of steam per pound of anthracite pea coal, at 1832° F. The maxi-

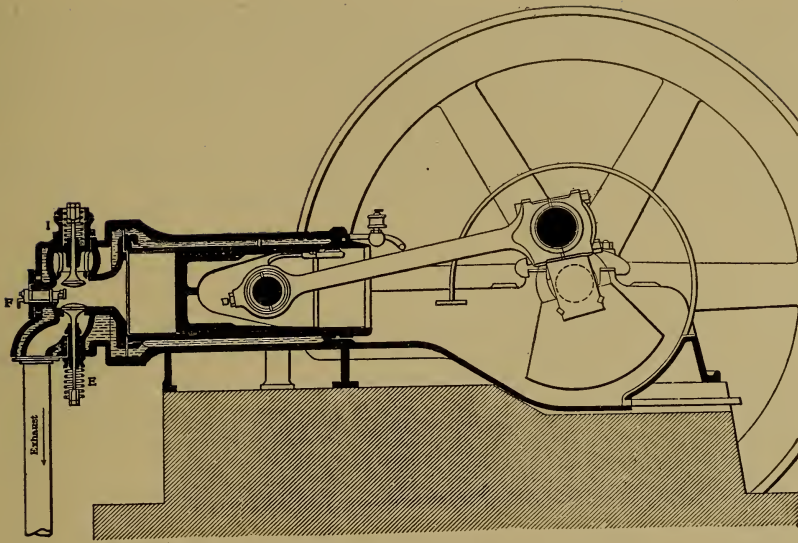

FIG. 116. Art. 287.—Single-acting Gas Engine, Four Cycle.

(From "The Gas Engine," by Cecil P. Poole, with the permission of the Hill Publishing Company.)

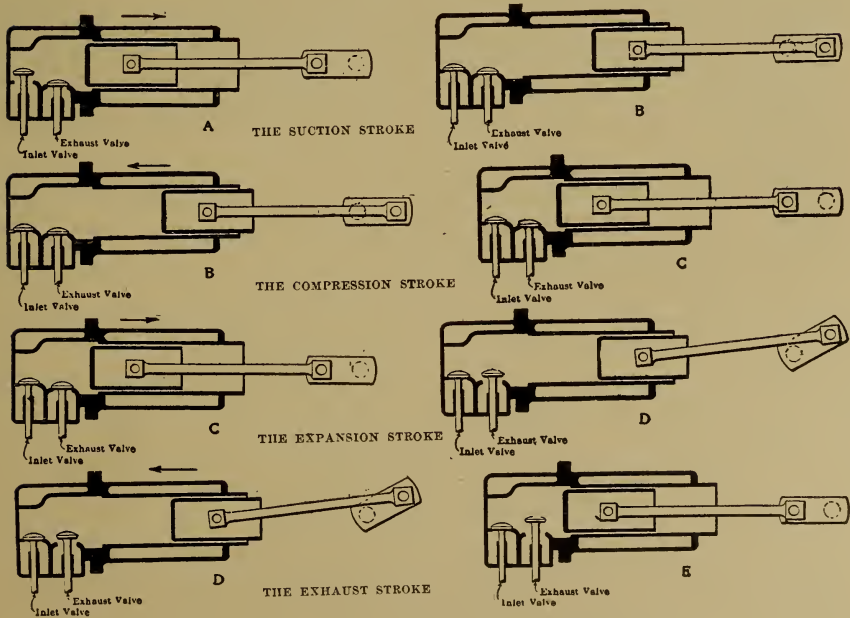

FIG. 117. Art. 288.—Piston Movements, Otto Cycle.

(From "The Gas Engine," by Cecil P. Poole, with the permission of the Hill Publishing Company.)

mum heat value in the gas was obtained when 0.72 lb. of steam was introduced (only 0.52 lb. of which was decomposed) per pound of coal. If we take the ratio of air to coal by weight at 9 lb., the ratio of steam decomposed to air supplied at highest heat value and heat efficiency is $0.52 \div 9.0 = 0.058$; approximately 6 per cent, as in Art. 284.

An interesting study of the principles involved may be found in *Bulletins of the University of Illinois*; vi, 16, by J. K. Clement, *On the Rate of Formation of Carbon Monoxide in Gas Producers*, and ix, 24, by Garland and Kratz, *Tests of a Suction Gas Producer*.

286. Figure of Merit. A direct and accurate determination of efficiency is generally impossible, on account of the difficulties in gas measurement (12). For comparison of results obtained from the same coals, the figure of merit is sometimes used. This is the quotient of the heating value per pound of the gas by the weight of carbon in a pound of gas: it is the *heating value of the gas per pound of carbon contained*. In the ideal case, for pure carbon, its value would be 10,050 B. t. u. For a hydrocarbonaceous coal, it may have a greater value.

GAS ENGINE CYCLES

287. Four-cycle Engine. A gas engine of one of the most commonly used types is shown in Fig. 116. This represents a single-acting engine; *i.e.* the gas is in contact with one side of the piston only, the other end being open. Large engines of this type are frequently made double-acting, the gas being then contained on both sides of a piston moving in an entirely closed cylinder, exhaust occurring on one side while some other phase of the cycle is described on the other side.

288. The Otto Cycle. Figure 117 illustrates the piston movements corresponding to the ideal pv diagram of Fig. 118. The cycle includes five distinctly marked paths. During the out stroke of the piston from position *A* to position *B*, Fig. 117, gas is sucked in by its movement, giving the line *ab*, Fig. 118. During the next inward stroke, *B* to *C*, the gas is compressed, the valves being closed, along the line *bc*. The cycle is not yet completed: two more strokes are necessary. At the beginning of the first of these, the piston being at *c*, Fig. 118, the gas is ignited and practically instantaneous combustion occurs at constant volume, giving the line *cC*. An out



FIG. 118. Arts. 288, 291.—The Otto Cycle.

stroke is produced, and as the valves remain closed, the gas expands, doing work along Cd , while the piston moves from C to D , Fig. 117. At d , the exhaust valve opens, and during the fourth stroke the piston moves in from D to E , expelling the gas from the cylinder along de , Fig. 118. This completes the cycle. The inlet valve has been open from a to b , the exhaust valve from d to e . During the remainder of the stroke, the cylinder was closed. Of the four strokes, only one was a "working" stroke, in which a useful effort was made upon the piston. In a *double-acting* engine of this type, there would be two working strokes in every four.

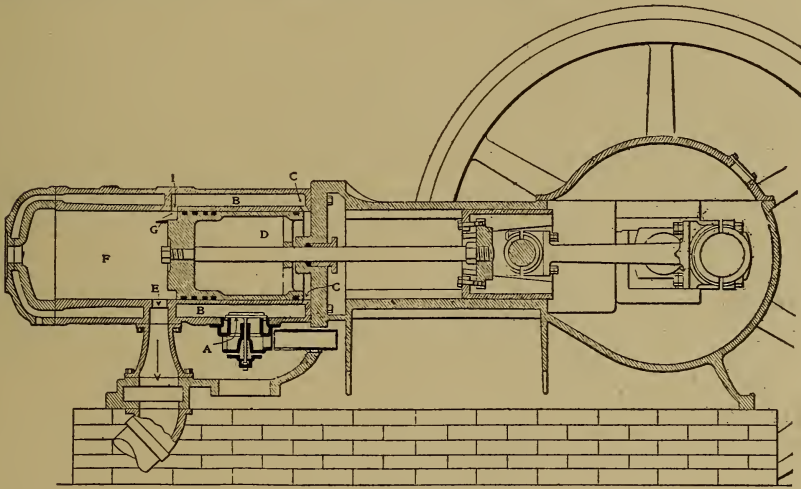

FIG. 119. Arts. 289-291, 309, 339. — Two-cycle Gas Engine.

(From "The Gas Engine," by Cecil P. Poole, with the permission of the Hill Publishing Company.)

289. Two-stroke Cycle. Another largely used type of engine is shown in Fig. 119. The same five paths compose the cycle; but the events are now crowded into two strokes. The exhaust opening is at E ; no valve is necessary. The inlet valve is at A , and ports are provided at C , C and I . The gas is often delivered to the engine by a separate pump, at a pressure several pounds above that of the atmosphere; in this engine, the otherwise idle side of a single-acting piston becomes itself a pump, as will appear. Starting in the position shown, let the piston move to the left. It draws a supply of combustible gas through A , B and the ports C into the chamber D . On the outward return stroke, the valve A closes, and the gas in D is compressed. Compression continues until the edge of the piston passes the port I , when this high pressure gas rushes into the space F , at

practically constant pressure. The piston now repeats its first stroke. Following the mass of gas which we have been considering, we find that it undergoes compression, beginning as soon as the piston closes the ports E and I , and continuing to the end of the stroke, when the piston is in its extreme left-hand position. Ignition there takes place, and the next out stroke is a working stroke, during which the heated gas expands. Toward the end of this stroke, the exhaust port E is uncovered, and the gas passes out, and continues to pass out until early on the next backward stroke this port is again covered.

290. Discussion of the Cycle. We have here a *two-stroke cycle*; for two of the four events requiring a perceptible time interval are always taking place simultaneously. On the first stroke to the left, while gas is entering D , it is for a brief interval of time also flowing from I to F , from F through E , and afterward being compressed in F . On the next stroke to the right, while gas is compressed in D , ignition and expansion occur in F ; and toward the end of the stroke, the exhaust of the burned gases through E and the admission of a fresh supply through I , both begin. The inlet port I and the exhaust port E are **both open at once** during part of the operation. To prevent, as far as possible, the fresh gas from escaping directly to the exhaust, the baffle G is fixed on the piston. It is only by skillful proportioning of port areas, piston speed, and pressure in D that large loss from this cause is avoided.* The burned gases in the cylinder, it is sometimes claimed, form a barrier between the fresh entering gas and the exhaust port.

291. PV Diagram. This is shown for the working side (space F) in Fig. 120 and for the pumping side (space D) in Fig. 121. The exhaust

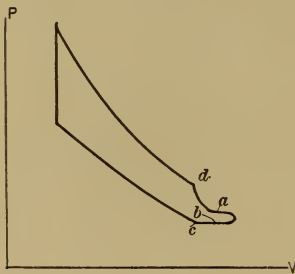

FIG. 120. Art. 291.—Two-stroke Cycle.

port is uncovered at d , Fig. 120, and the pressure rapidly falls. At a , the inlet port opens, the fresh supply of gas holding up the pressure. From a out to the end of the diagram, and back to b , both ports are open. At b the inlet port closes, and at c the exhaust port, when compression begins. The pump diagram of Fig. 121 corresponds with the negative loop $deab$ of Fig. 118. Aside from the slight difference at $dabc$, Fig. 120, the

negative loop $deab$ of Fig. 118. Aside from the slight difference at $dabc$, Fig. 120, the



FIG. 121. Art. 291.—Two-stroke Cycle Pump Diagram.

* Two cycle gas engines should never be governed by varying the quantity of mixture drawn in (Art. 348) because of the disturbing effect which such variations would have on these factors.

diagrams for the two-cycle and four-cycle engines are precisely the same; and in actual indicator cards, the difference is very slight.

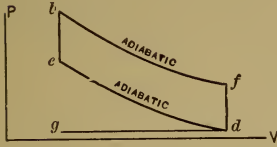

FIG. 122. Arts. 292, 293, 294, 295, 314, 329, 329a, 329b, 331. Prob. 15.—Idealized Gas Engine Diagram.

292. Ideal Diagram. The perfect PV diagram for either engine would be that of Fig. 122, $ebfd$, in which expansion and compression are adiabatic, combustion instantaneous, and exhaust and suction unrestricted; so that the area of the negative loop dg becomes zero, and eb and fd are lines of constant volume. From inspection of the diagram we find

$$P_e V_e^y = P_d V_d^y, \quad T_e = T_d \left(\frac{V_d}{V_e} \right)^{y-1}, \quad P_f V_f^y = P_b V_b^y, \quad V_f = V_d,$$

$$P_e = P_d \left(\frac{V_d}{V_e} \right)^y, \quad T_b = T_e \frac{P_b}{P_e}, \quad P_f = P_b \left(\frac{V_b}{V_f} \right)^y, \quad V_b = V_e,$$

$$T_f = T_d \frac{P_f}{P_d}.$$

293. Work Done. The work area under bf is $\frac{P_b V_b - P_f V_f}{y - 1}$; that under ed is $\frac{P_e V_e - P_d V_d}{y - 1}$; the net work of the cycle is

$$\frac{P_b V_b + P_d V_d - P_f V_f - P_e V_e}{y - 1}.$$

This may be written in terms of two pressures and two volumes only, for $P_e V_e = P_d V_d^y V_b^{1-y}$ and $P_f V_f = P_b V_b^y V_d^{1-y}$, giving

$$W = \frac{P_b V_b + P_d V_d - P_b V_b^y V_d^{1-y} - P_d V_d^y V_b^{1-y}}{y - 1}$$

$$= \frac{1}{y - 1} \left\{ P_b V_b + V_d \left[P_d - \left(\frac{V_b}{V_d} \right)^y P - \left(\frac{V_b}{V_d} \right)^{1-y} P_d \right] \right\}.$$

294. Relations of Curves. Expressing $\frac{P_b}{P_f} = \left(\frac{V_f}{V_b} \right)^y$ and $\frac{P_e}{P_d} = \left(\frac{V_d}{V_e} \right)^y$, and remembering that $V_b = V_e$, $V_f = V_d$, we have $\frac{P_b}{P_f} = \frac{P_e}{P_d}$ and $\frac{P_b}{P_e} = \frac{P_f}{P_d}$. This permits of rapidly plotting one of the curves when the other is given. We also find $\frac{T_b}{T_f} = \frac{T_e}{T_d}$ and $\frac{T_b}{T_e} = \frac{T_f}{T_d}$.

295. Efficiency. In Fig. 122, heat is absorbed along eb , equal to $l(T_b - T_e)$; this is derived from the combustion of the gas. Heat is rejected along fd , $= l(T_f - T_d)$. Using the difference of the two quantities as an expression for the work done, we obtain for the efficiency

$$\begin{aligned} \frac{T_b - T_e - T_f + T_d}{T_b - T_e} &= 1 + \frac{T_d - T_f}{T_b - T_e} = 1 - \frac{T_f}{T_b} \\ &= \frac{T_b - T_f}{T_b} = \frac{T_e - T_d}{T_e} = 1 - \left(\frac{P_d}{P_e}\right)^{\frac{\gamma-1}{\gamma}}. \end{aligned}$$

The efficiency thus depends solely upon the extent of compression and since $\left(\frac{P_d}{P_e}\right) = \left(\frac{V_d}{V_e}\right)^\gamma$, while $\frac{V_e}{V_d - V_e}$ = the clearance of the engine,

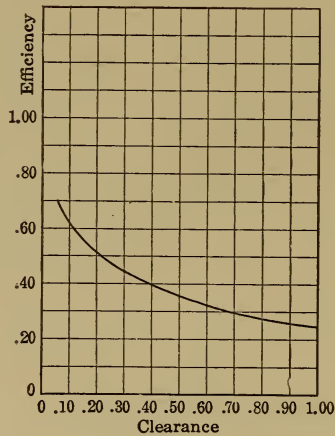

FIG. 122a. Art. 295.—Relation between Efficiency and Clearance in the Ideal Cycle.

the efficiency may be expressed *in terms of the clearance only*. (See Fig. 122a.)

295 a. The Sargent Cycle. Let the engine draw in its charge at atmospheric pressure, along ad , Fig. 122 c. The inlet valve closes at d and the charge expands somewhat, along dc . It is then compressed along cde , ignited along eb , and expanded along bg . The exhaust valve opens at g , the pressure falls to that of the atmosphere along gh , and the cylinder contents are expelled along ha . The work area is $debfg$; there is no negative loop work area dhc . The entropy diagram shows the cycle to

be more efficient than the Otto cycle *defb* between the same temperature limits; the superior Otto cycle *ebgc* has wider temperature limits. The gain by the Sargent cycle is analogous to that in a steam engine by an increased ratio of expansion (Art. 411), and involves a reduction in capacity in proportion to the size of cylinder. The efficiency is

$$\begin{aligned} \frac{debgh}{mebn} &= \frac{mebn - mdhgn}{mebn} \\ &= 1 - \frac{k(T_h - T_d) + l(T_g - T_h)}{l(T_b - T_e)} \\ &= 1 - y \frac{T_h - T_d}{T_b - T_e} - \frac{T_g - T_h}{T_b - T_e}. \end{aligned}$$

295 b. The Frith Regenerative Cycle (*Jour. A. S. M. E.*, XXXII, 7). In Fig. 122 *d*, *abcd* is an ordinary Otto cycle. Suppose that during expansion some of the fluid passes through a regenerator, giving up heat, following some such path as *ae*. Then let the regenerator in turn impart this heat to the working substance during or just before combustion, as along *di* in the entropy diagram.

If the regenerator were perfect, and the transfers as described could occur, the heat absorbed from external sources would be *jiah* and the work would be *daec*. The quotient of the latter by the former, if the path through the regenerator were *ac* (limiting case), would be unity. But this would involve a contravention of the second law, since heat would have to pass from the regenerator (at *c*) to a substance hotter than itself (at *d*). If, however, we make the temperature range $T_d - T_c$ very small, a large proportion of the heat transferred to the regenerator may again be absorbed along *da*, and as the output of the engine approaches zero, its efficiency approaches 100 per cent.

If, as in Fig. 122 *b*, the expansion curve strikes the point *c*, we may assume that of all the heat (*fcah*) delivered to the regenerator, only that portion (*lka*h), the temperature of which exceeds T_d , can be redelivered to the fluid along *da*. The efficiency is then

$$\begin{aligned} \frac{dac}{fdah - lka} &= \frac{fdah - fcah}{fdah - lka} \\ &= \frac{l(T_a - T_d) - s(T_a - T_c)}{l(T_a - T_d) - s(T_a - T_k)} = \frac{T_a - T_d - \frac{n-y}{n-1}(T_a - T_c)}{T_a - T_d - \frac{n-y}{n-1}(T_a - T_d)}, \end{aligned}$$

where $s = l \frac{n-y}{n-1}$ is the specific heat along the path *ack*, the equation of which is

$pv^n = \text{const.}$ Since $P_a V_a^n = P_c V_c^n$, while $P_d V_d^y = P_c V_c^y$,

$$n = y \frac{\log \frac{P_c}{P_a}}{\log \frac{P_c}{P_d}}.$$

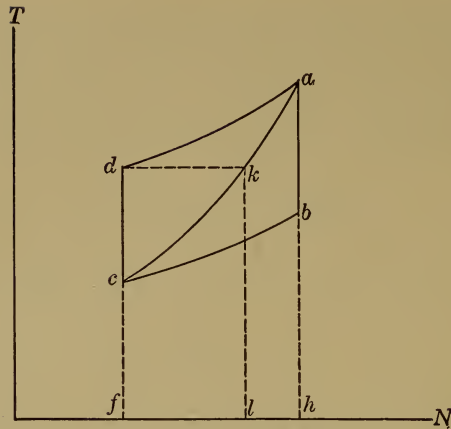

FIG. 122b. Art. 295b.

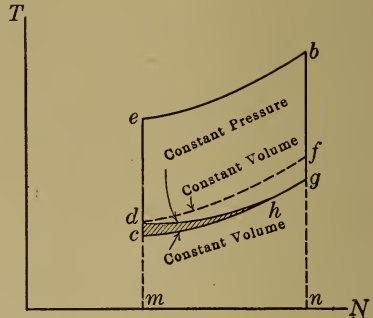
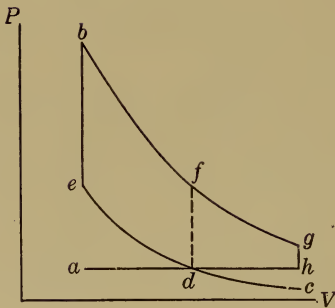

FIG. 122c. Art. 295a.

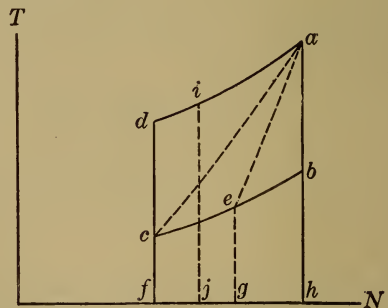
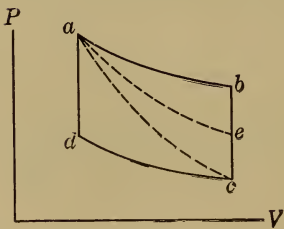

FIG. 122d. Art. 295b.

Let $P_c = 14.7$, $P_d = 147$, $P_a = 294$.

Then
$$n = 1.402 \frac{\log 0.05}{\log 0.10} = 1.963,$$

$$\frac{n - y}{n - 1} = \frac{0.561}{0.963} = 0.582.$$

Now if $T_c = 300^\circ \text{ F.} = 760^\circ \text{ abs.}$, $T_d = 1470^\circ \text{ abs.}$, and if $T_a = 3000^\circ \text{ abs.}$, the efficiency becomes

$$\frac{1530 - (0.582 \times 2240)}{1530 - (0.582 \times 1530)} = \frac{230}{640} = 0.36,$$

while that of the Otto cycle is

$$\frac{T_d - T_c}{T_d} = \frac{1470 - 760}{1470} = 0.48.$$

296. Carnot Cycle and Otto Cycle; the Atkinson Engine. Let $abcd$, Fig. 123, represent a Carnot cycle drawn to pv coordinates, and bfd , the corresponding Otto cycle between the same temperature limits, T and t . For the Carnot cycle, the efficiency is $(T - t) \div T$; for the Otto, it is, as has been shown, $(T_e - T_d) \div T_e$. It is one of the disadvantages of the Otto cycle, as shown in Art. 294, that the range of temperatures during expansion is the same as that during compression. In the ingenious *Atkinson* engine (13), the fluid was contained in the space between *two* pistons, which space was varied during the phases of the cycle. This permitted of expansion independent of compression; in the ideal case, expansion continued down to the temperature of the atmosphere, giving such a diagram as $ebcd$, Fig. 123. The entropy diagrams for the Carnot, Otto, and Atkinson cycles are correspondingly lettered in Fig. 124. For the Atkinson cycle, in the ideal case, we have in Fig. 124 the elementary strip $wvxy$, which may stand for dH , and the isothermal dc at the temperature t . Let the variable temperature along eb be T_x , having for its limits T_b and T_e . Then for the area $ebcd$, we have

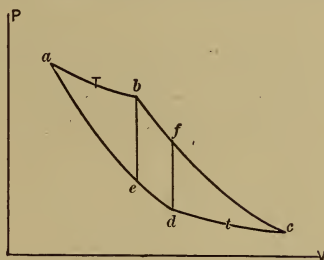

FIG. 123. Art. 296.—Carnot, Otto, and Atkinson Cycles.

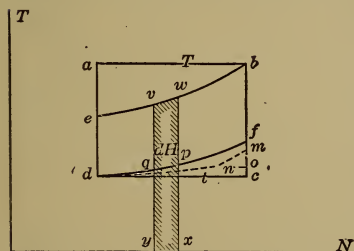

FIG. 124. Ar's. 296, 297, 305, 307, 329b. Efficiencies of Gas Engine Cycles.

$$\begin{aligned} W &= \int_{T_e}^{T_b} \frac{dH}{T_x} (T_x - t) = l \int_{T_e}^{T_b} \frac{dT_x}{T_x} (T_x - t) \\ &= l(T_b - T_e) - lt \log_e \frac{T_b}{T_e}. \end{aligned}$$

The *efficiency* is obtained by dividing by $l(T_b - T_e)$ and is equal to

$$1 - \frac{t}{T_b - T_e} \log_e \frac{T_b}{T_e}.$$

297. Application to a Special Case. Let $T_e = 1060$, $T = 3440$, $t = 520$; whence, from Art. 294, $T_f = 1688$. We then have the following ideal efficiencies:

$$\text{Carnot,} \quad \frac{T - t}{T'} = \frac{3440 - 520}{3440} = 0.85.$$

$$\text{Atkinson, } 1 - \frac{t}{T_b - T_c} \log_e \frac{T_b}{T_c} = 1 - \frac{520}{2380} \log_e \frac{3440}{1060} = 0.74.$$

$$\text{Otto,} \quad \frac{T_c - t}{T_c} = \frac{1060 - 520}{1060} = 0.51.$$

The Atkinson engine can scarcely be regarded as a practicable type; the Otto cycle is that upon which most gas engine efficiencies must be based; and they depend solely on the ratio of temperatures or pressures during compression.

298. Lenoir Cycle. This is shown in Fig. 125. The fluid is drawn into the cylinder along Ad and exploded along df . Expansion then occurs, giving the path fg , when the exhaust valve opens, the pressure

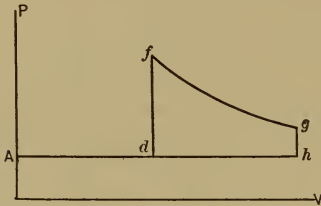

FIG. 125. Arts. 298, 301, 302. — Lenoir Cycle.

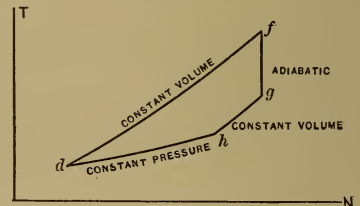

FIG. 126. Art. 298. — Entropy Diagram, Lenoir Cycle.

falls, gh , until it reaches that of the atmosphere, and the gases are finally expelled on the return stroke, hA . It is a *two-cycle* engine. The net entropy diagram appears in Fig. 126.

The efficiency is

$$\begin{aligned} \frac{\text{Heat absorbed} - \text{heat rejected}}{\text{Heat absorbed}} &= \frac{l(T_f - T_d) - l(T_g - T_h) - k(T_h - T_d)}{l(T_f - T_d)} \\ &= 1 - \frac{T_g - T_h}{T_f - T_d} - y \frac{T_h - T_d}{T_f - T_d}. \end{aligned}$$

299. Brayton Cycle. This is shown in Fig. 127. A separate pump is employed. The substance is drawn in along Ad , compressed along dn , and forced into a reservoir along nB . The engine begins to take a charge from the reservoir at B , which is slowly fed in and ignited as it enters, so that combustion proceeds at the same rate as the piston movement, giving the constant pressure line Bb . Expansion then occurs along bg , the exhaust valve opens at g , and the charge is expelled along hA . The net cycle is $dnbgh$; the net ideal entropy diagram is as in Fig. 128. This is also a two-cycle

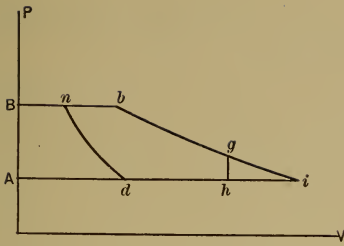

FIG. 127. Arts. 299, 302.—Brayton Cycle.

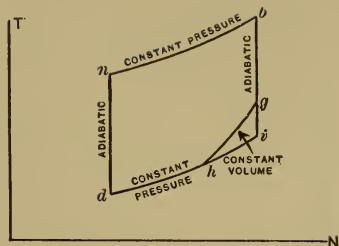

FIG. 128. Art. 299.—Brayton Cycle, Entropy Diagram.

engine. The “constant pressure” cycle which it uses was suggested in 1865 by Wilcox. In 1873, when first introduced in the United States, it developed an efficiency of 2.7 lb. of (petroleum) oil per brake hp.-hr.

The efficiency is (Fig. 127)

$$\frac{k(T_b - T_n) - l(T_g - T_h) - k(T_h - T_d)}{k(T_b - T_n)} = 1 - \frac{T_g - T_h}{y(T_b - T_n)} - \frac{T_h - T_d}{T_b - T_n}.$$

If expansion is complete, the cycle becoming *dnci*, Figs. 127, 128, then $T_g = T_h = T_i$, and the efficiency is

$$1 - \frac{T_i - T_d}{T_b - T_n} = 1 - \frac{T_d}{T_n} = \frac{T_n - T_d}{T_n},$$

a result identical with that in Art. 295; the efficiency (with complete expansion) depends solely upon the extent of compression.

300. Comparisons with the Otto Cycle. It is proposed to compare the capacities and efficiencies of engines working in the Otto,* Brayton, and Lenoir cycles; the engines being of the same size, and working between the same limits of temperature. For convenience, pure air will be regarded as the working substance. In each case let the stroke be 2 ft., the piston area 1 sq. ft., the external atmosphere at 17° C., the maximum temperature attained, 1537° C. In the Lenoir engine, let ignition occur at half stroke; in the Brayton, let compression begin at half stroke and continue until the pressure is the same as the maximum pressure attained in the Lenoir cycle, and let expansion also begin at half stroke. These are to be compared with an Otto engine, in which the pump compresses 1 cu. ft. of free air to 40 lb. net pressure. This quantity of free air, 1 cu. ft., is then supplied to each of the three engines.

301. Lenoir Engine. The expenditure of heat (in work units) along *df*, Fig. 125, is $Jl(T - t)$, in which $T = 1537$, $t = 17$, J is the mechanical equivalent of a Centigrade heat unit, and l is the specific heat of 1 cu. ft. of free air,

* The “Otto cycle” in this discussion is a modified form (as suggested by Clerk) in which the strokes are of unequal length.

heated at constant volume 1°C . Now $J = 778 \times \frac{2}{3} = 1400.4$, and Jl is approximately $0.1689 \times 0.075 \times 1400.4 = 17.72$. The expenditure of heat is then

$$17.72(1537 - 17) = 26,900 \text{ ft.-lb.}$$

The pressure at f is

$$14.7 \frac{1537 + 273}{17 + 273} = 91.4 \text{ lb. absolute;}$$

and the pressure at g is

$$91.4\left(\frac{1}{2}\right)^y = 34.25 \text{ lb. absolute.}$$

The work done under fg is then

$$144 \left\{ \frac{(91.4 \times 1) - (34.25 \times 2)}{1.402 - 1} \right\} = 8190 \text{ ft.-lb.}$$

The negative work under hd is $14.7 \times 144 \times 1 = 2107$ ft.-lb., and the net work is $8190 - 2107 = 6083$ ft.-lb. The efficiency is then $6083 \div 26,900 = 0.226$.

302. Brayton Engine. We first find (Fig. 127)

$$T_n = T_d \left(\frac{P_n}{P_d} \right)^{\frac{y-1}{y}} = (273 + 17) \left(\frac{91.4}{14.7} \right)^{0.286} = 489^\circ \text{ absolute or } 216^\circ \text{C.}$$

Proceeding in the same way as with the Lenoir engine, we find the heat expenditure to be

$$Jk(T_b - T_n) = 0.2375 \times 0.075 \times 1400.4(1537 - 216) = 33,000 \text{ ft.-lb.}$$

The pressure at n is by assumption equal to that in the case of the Lenoir engine; the pressure at g in the Brayton type then equals that at g in the Lenoir. The work under bg is the same as that under fg in Fig. 125. The work under nb is found by first ascertaining the volume at n . This is

$$\left(\frac{1.47}{9.14} \right)^{1+y} 1.0 = 0.272.$$

The work under nb is then $91.4 \times 144 \times (1.0 - 0.272) = 9650$ ft.-lb., and the gross work is $9650 + 8190 = 17,840$ ft.-lb. Deducting the negative work under hd , 2107 ft.-lb., and that under dn ,

$$144 \left(\frac{(91.4 \times 0.272) - (14.7 \times 1)}{1.402 - 1.0} \right) = 3650 \text{ ft.-lb.,}$$

the net work area is $12,083$ ft.-lb., and the efficiency, $12,083 \div 33,000 = 0.366$.

303. Clerk's Otto Engine. In Fig. 129, a separate pump takes in a charge along AB , and compresses it along BC , afterward forcing it into a receiver along CD at 40 lb. gauge pressure. Gas flows from the receiver into the engine along DC , is exploded along CE , expands to F , and is expelled along GA . The net cycle is $BCEFG$. The volume at C is

$$\left(\frac{14.7}{54.7} \right)^{1+y} = 0.393 \text{ cu. ft.}$$

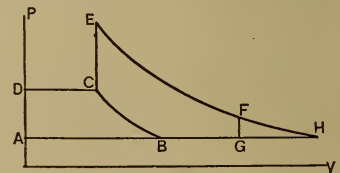

FIG. 129. Arts. 303, 305.—Clerk's Otto Cycle.

The temperature at C is

$$P_c V_c T_b \div P_b V_b = \frac{(54.7 \times 0.393)(273 + 17)}{14.7 \times 1} - 273 = 153^\circ \text{C.}$$

The pressure at E is then

$$\frac{(1537 + 273)54.7}{153 + 273} = 231 \text{ lb. absolute.}$$

The pressure at F is

$$231 \left(\frac{0.393}{2} \right)^y = 23.64 \text{ lb. absolute.}$$

The work under EF is

$$144 \left(\frac{(231 \times 0.393) - (23.64 \times 2)}{1.402 - 1.0} \right) = 15,600 \text{ ft.-lb.,}$$

that under BG is 2107 ft.-lb., and that under BC is

$$144 \left(\frac{(54.7 \times 0.393) - (14.7 \times 1)}{1.402 - 1.0} \right) = 2430 \text{ ft.-lb.}$$

The net work is $15,600 - 2107 - 2430 = 11,063$ ft.-lb. The heat expenditure in this case is $Jl(T_E - T_C) = 17.72 \times (1537 - 153) = 24,500$ ft.-lb., and the efficiency is $11,063 \div 24,500 = 0.453$; considerably greater than that of either the Lenoir or the Brayton engine (14). If we express the cyclic area as 100, then that of the Lenoir engine is 52 and that of the Brayton engine is 104.

304. Trial Results. These comparisons correspond with the consumption of gas found in actual practice with the three types of engine. The three efficiencies are 0.226, 0.366, and 0.453. Taking 4 cu. ft. of free gas as ideally capable of giving one horse power per hour, the gas consumption per hp.-hr. in the three cases would be respectively $4 \div 0.226 = 17.7$, $4 \div 0.366 = 10.9$, and $4 \div 0.453 = 8.84$ cu. ft. Actual tests gave for the Lenoir and Hugon engines 90 cu. ft.; for the Brayton, 50; and for the modified Otto, 21. The possibility of a great increase in economy by the use of an engine of a form somewhat similar to that of the Brayton will be discussed later.

305. Complete Pressure Cycle. The cycle of Art. 303 merits detailed examination. In Fig. 129, the heat absorbed is $l(T_E - T_C)$; that rejected is

$$l(T_F - T_G) + k(T_G - T_B);$$

the efficiency is

$$1 - \frac{T_F - T_G}{T_E - T_C} - y \frac{T_G - T_B}{T_E - T_C}.$$

The entropy diagram may be drawn as $ebmd$, Fig. 124, showing this cycle to be more efficient than the equal-length-stroke Otto cycle, but less efficient than the Atkinson. With *complete expansion* down to the lower pressure limit, the cycle becomes $BCEFH$, Fig. 129, or $ebod$, Fig. 124; the strokes are still of unequal length, and the efficiency is (Fig. 129)

$$1 - y \frac{T_H - T_B}{T_E - T_C}.$$

If the strokes be made of equal length, with *incomplete* expansion, $T_G = T_B$, the cycle becomes the ordinary Otto, and the efficiency is

$$1 - \frac{T_F - T_G}{T_E - T_C} = \frac{T_C - T_B}{T_C}.$$

306. Oil Engines: The Diesel Cycle. Oil engines may operate in either the two-stroke or the four-stroke cycle, usually the latter; and combustion may occur at constant volume (Otto), constant pressure (Brayton), or constant temperature (Diesel). Diesel, in 1893 (15), first proposed what has proved to be from a thermal standpoint the most economical heat engine. It is a four-cycle engine, approaching more closely than the Otto to the Carnot cycle, and theoretically applicable to solid, liquid, or

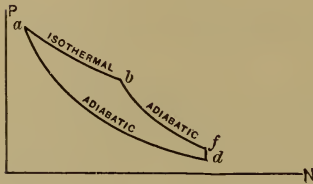

FIG. 130. Arts. 306, 307.—Diesel Cycle.

gaseous fuels, although actually used only with oil. The first engine, tested by Schröter in 1897, gave indicated thermal efficiencies ranging from 0.34 to 0.39 (16). The idealized cycle is shown in Fig. 130. The operations are adiabatic compression, isothermal expansion, adiabatic expansion, and discharge at constant volume. Pure air is compressed to a high pressure and temperature, and a spray of oil is then gradually injected by means of external air pressure. The temperature of the cylinder is so high as at once to ignite the oil, the supply of which is so adjusted as to produce combustion practically at constant temperature. Adiabatic expansion occurs after the supply of fuel is discontinued. A considerable excess of air is used. The pressure along the combustion line is from 30 to 40 atmospheres, that at which the oil is delivered is 50 atmospheres, and the temperature at the end of compression approaches 1000° F. The engine is started by compressed air; two or more cylinders are used. There is no uncertainty as to the time of ignition; it begins immediately upon the entrance of the oil into the cylinder. To avoid pre-ignition in the supply tank, the high-pressure air used to inject the oil must be cooled. The cylinder is water-jacketed. Figure 131 shows a three-cylinder engine of this type; Fig. 132, its actual indicator diagram, reversed.

The Diesel engine has recently attracted renewed interest, especially in small units: although it has been built in sizes up to 2000 hp. It has been applied in marine service, and has successfully utilized by-product tar oil.

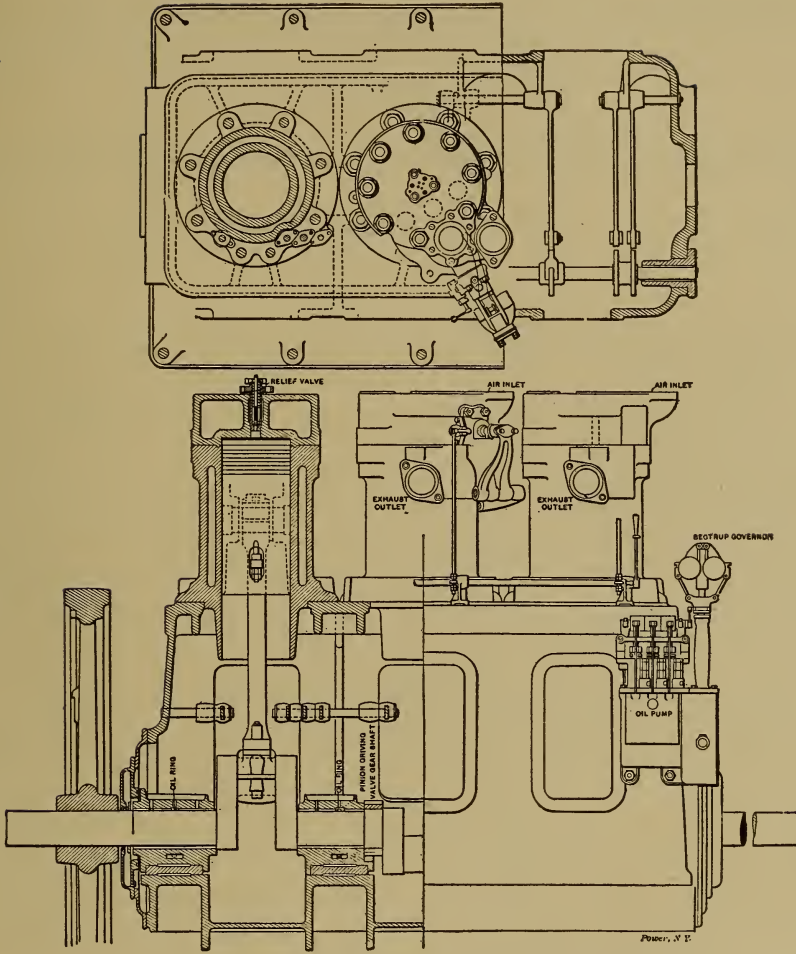

FIG. 131. Art. 306.— Diesel Engine. (American Diesel Engine Company.)

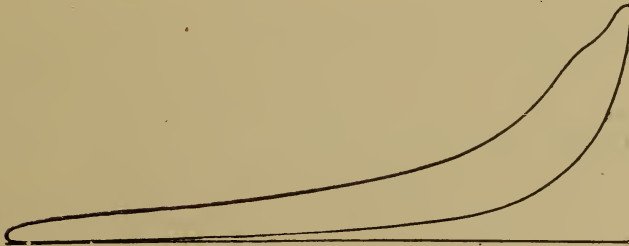

FIG. 132. Art. 306.— Indicator Diagram, Diesel Engine.
(16 x 24 in. engine, 160 r.p.m. Spring 400.)

377. **Efficiency.** The heat absorbed along ab , Fig. 130, is

$$P_a V_a \log_e \frac{V_b}{V_a} = R T_a \log_e \frac{V_b}{V_a}.$$

The heat rejected along fd is $l(T_f - T_d)$. We may write the efficiency as

$$1 - \frac{l(T_f - T_d)}{R T_a \log_e \frac{V_b}{V_a}}.$$

But $T_f = T_b \left(\frac{V_b}{V_f}\right)^{\gamma-1} = T_a \left(\frac{V_b}{V_f}\right)^{\gamma-1}$, and $T_a = T_d \left(\frac{V_f}{V_a}\right)^{\gamma-1}$; whence

$$T_f = T_d \left(\frac{V_f}{V_a}\right)^{\gamma-1} \left(\frac{V_b}{V_f}\right)^{\gamma-1} = T_d \left(\frac{V_b}{V_a}\right)^{\gamma-1}.$$

For the heat rejected along fd we may therefore write

$$\frac{k}{\gamma} T_d \left[\left(\frac{V_b}{V_a}\right)^{\gamma-1} - 1 \right],$$

and for the efficiency,

$$1 - \frac{k T_d \left[\left(\frac{V_b}{V_a}\right)^{\gamma-1} - 1 \right]}{\gamma R T_a \log_e \frac{V_b}{V_a}}.$$

This increases as T_a increases and as $\frac{V_b}{V_a}$ decreases. The last conclusion is of prime importance, indicating that the *efficiency should increase at light loads*. This may be apprehended from the entropy diagram, $abfd$, Fig. 124. As the width of the cycle decreases (bf moving toward ad), the efficiency increases.

307 b. Diesel Cycle with Pressure Constant. In common present practice, the engine is supplied with fuel at such a rate that the pressure, rather than the temperature, is kept constant during combustion. This gives a much greater work area, in a cylinder of given size, than is possible with isothermal combustion. The cycle is in this case as shown in Fig. 132 a, combining features of those of Otto and Brayton. The entropy diagram shows that the efficiency exceeds that of the Otto cycle $ebfd$ between the

same limits; but it is less than that of the Diesel cycle with isothermal combustion. The definite expression for efficiency is

$$\frac{abfd}{mabn} = 1 - \frac{l(T_f - T_a)}{k(T_b - T_a)} = 1 - \frac{T_f - T_a}{y(T_b - T_a)}$$

Inspection of the diagram shows that the efficiency *decreases* as the load *increases*.

(For a description of the Junkers engine, see the papers by Junge, in *Power*, Oct. 22, 29, Nov. 5, 1912.)

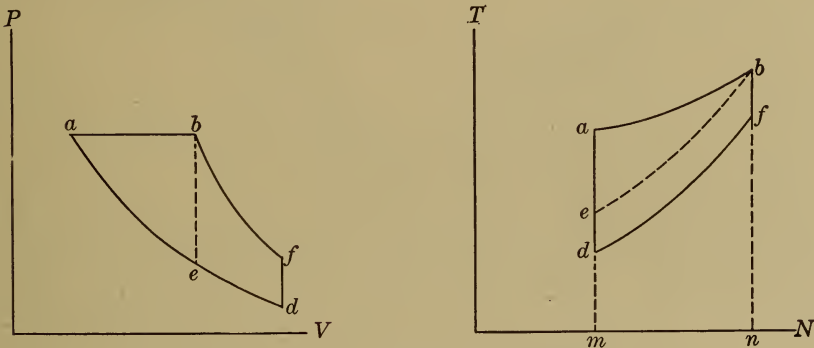

FIG. 132a. Art. 307b.—Constant-pressure Diesel Cycle.

307c. Entropy Diagram, Diesel Engine. In constructing the entropy diagram from an actual Diesel indicator card a difficulty arises similar to one met with in steam engine cards; the quantity of substance in the cylinder is *not constant* (Art. 454). This has been discussed by Eddy (17), Frith (18), and Reeve (19). The illustrative diagram, constructed as in Art. 347, is suggestive. Figure 133 shows such a diagram for an engine tested by Denton (20). The initially hot cylinder causes a rapid absorption of heat from the walls during the early part of compression along *ab*. Later, along *bc*, heat is transferred in the opposite direction. Combustion occurs along *cd*, the temperature and quantity of heat increasing rapidly. During expansion, along *de*, the temperature falls with increasing rapidly, the path becoming practically adiabatic during release, along *ef*. The *TV* diagram of Fig. 133 indicates that no further rise of temperature would accompany increased compression; the actual path at *y* has already become practically isothermal.

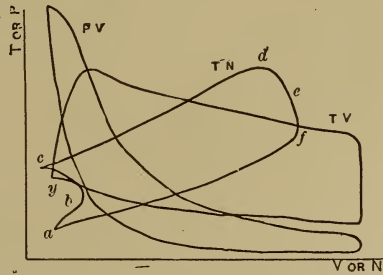

FIG. 133. Art. 307.—Diesel Engine Diagrams.

308. Comparison of Cycles. Figure 134 shows all of the cycles that have been discussed, on a single pair of diagrams. The lettering corresponds with that in Figs. 122-128, 130. The cycles are,

Carnot, $abcd$, Lenoir, $df_0g_0h_0, d, f_0i_0$, Diesel, $dabf$,
 Otto, $ebfd$, Brayton, $dnbgh, dnbi$, Atkinson, $ebcd$,
 Complete pressure, $debg, debi$.

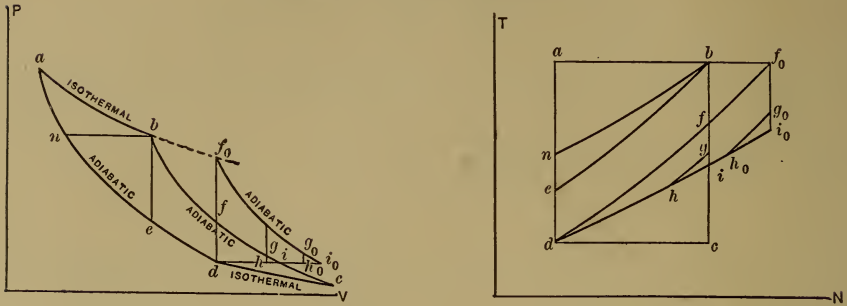

FIG. 134. Art. 308, Probs. 7, 25. — Comparison of Gas Engine Cycles.

308a. The Humphrey Internal Combustion Pump. In Fig. 134a, C is a chamber supplied with water through the check valves V from the storage tank ET , and connected by the discharge pipe D with the delivery tank F . Suppose the lower part of C , with the pipe D and the tank F , to be filled with water, and a combustible charge of gas to be present in the upper part of C , the valves I and E being closed. The gas charge is exploded, and expansion forces the water down in C and up in F . The movement does not stop when the pressure of gas in C falls to that equivalent to the difference in head between F and C ; on the contrary, the kinetic energy of the moving water carries it past the normal level in F , and the gases in C fall below the pressure of the atmosphere. This causes the opening of E and V , an inflow of water from ET to C , and an escape of burnt gas from C through E . The water rises in C . Meanwhile, a partial return flow from F aids to fill C , the kinetic energy of the moving water having been exhausted, and the stream having come to rest with an abnormally high level in F . Water continues to enter C until (1) the valves V are closed, (2) the level of E is reached, when that valve closes by the impact of water; and (3) the small amount of burnt gas now trapped in the space C_1 is compressed to a pressure higher than that corresponding with the difference of heads between F and C_1 . As soon as the returning flow of water has this time been brought to rest, the excess pressure in C_1 starts it again in the opposite direction from C_1 toward F . When the pressure in C_1 has by this means fallen to about that of the atmosphere, a fresh charge is drawn in through I . Frictional losses prevent the water, this time, from rising as high in F as on its first outflow; but nevertheless it does rise sufficiently high to acquire

a static head, which produces the final return flow which finally compresses the fresh charge.

The water here takes the place of a piston (as in the hydraulic piston compressor, Art. 240). The only moving parts are the valves.

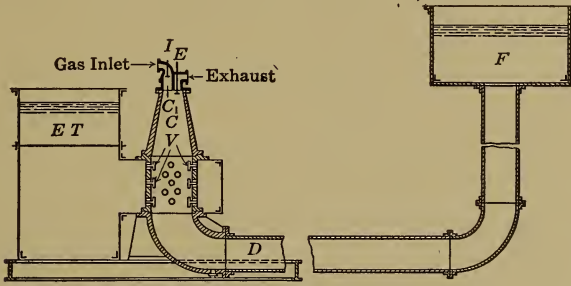

FIG. 134a. Art. 308a.—Humphrey Pump.

The action is unaccompanied by any great rise of temperature of the metal, since nearly all parts are periodically swept by cold water. The pump as described works on the four-cycle principle, the operations being (Fig. 134b):

- a. Ignition (*ab*) and expansion (*bc*);
- b. Expulsion of charge (*cd, de*), suction of water, compression of residual charge (*ef*);
- c. Intake (*feg, gh*);
- d. Compression (*ha*).

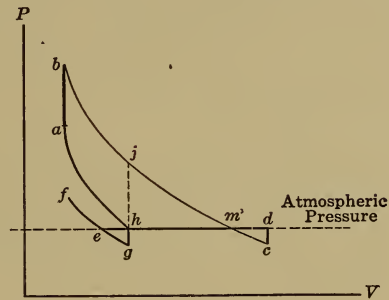

FIG. 134b. Art. 308a.—Cycle of Humphrey Pump.

Disregarding the two loops *ehg, dcm*, the cycle is bounded by two polytropics, one line of constant volume and one of constant pressure. Between the temperature limits T_b and T_h it gives more work than the Otto cycle *habj*, and if the curves *bc* and *ah* were adiabatic would necessarily have a higher efficiency than the Otto cycle. The actual paths are not adiabatic: during expansion (as well as during ignition) some of the heat must be given up to the water; while the heat generated by compression is similarly (in part) transferred to the water along *ha*. With the adiabatic assumption adopted for the purpose of classification, the cycle is that described in Art. 305 and shown in Fig. 134 as *debi*. The strokes are of unequal length.

The gases are so cool toward the end of expansion that a fresh

charge may be safely introduced at that point, by outside compression on the two-cycle principle (Art. 289). The pump may be adapted for high heads by the addition of the hydraulic intensifier. It has been built in sizes up to 40,000,000 gal. per twenty-four hours, and has developed a thermal efficiency (to water) under test of about 22 per cent. (See *American Machinist*, Jan. 5, 1911.)

PRACTICAL MODIFICATIONS OF THE OTTO CYCLE.

309. Importance of Proper Mixture. The working substance used in gas engines is a mixture of gas, oil vapor or oil, and air. Such mixtures will not ignite if too weak or too strong. Even when so proportioned as to permit of ignition, any variation from the correct ratio has a detrimental effect; if *too little* air is present, the gas will not burn completely, the exhaust will be dark-colored and odorous, and unburned gas may explode in the exhaust pipe when



FIG. 135. Art. 309.—Effect of Mixture Strength.

it meets more air. If *too much* air is admitted, the products of combustion will be unnecessarily diluted and the rise of temperature during ignition will be decreased, causing a loss of work area on the PV diagram. Figure 135 shows the effect on rise of temperature and pressure of varying the proportions of air and gas, assuming the variations to remain within the limits of possible ignition. Failure to ignite may occur as a result of the presence of excess of air as well as when the air supply is deficient. *Rapidity*

of flame propagation is essential for efficiency, and this is only possible with a proper mixture. The gas may in some cases burn so slowly as to leave the cylinder partially unconsumed. In an engine of the type shown in Fig. 119, this may result in a spread of flame through *I*, *B*, and *C* back to *D*, with dangerous consequences.

310. Methods of Mixing. The constituents of the mixture must be intimately mingled in a finely divided state, and the governing of the engine should preferably be accomplished by a method which keeps the proportions at those of highest efficiency. Variations of pressure in gas supply mains may interpose serious difficulty in this respect. Fluctuations in the *lights* which may be supplied from the same mains are also excessive as the engine load changes. Both difficulties are sometimes obviated in small units by the use of a rubber supply receiver. Variations in the speed of the engine often change the proportions of the mixture. When the air is drawn from out of doors, as with automobile engines, variations in the temperature of the air affect the mixture composition. In simple types of engine, the relative openings of the automatic gas and air inlet valves are fixed when the engine is installed, and are not changed unless the quality or pressure of the gas changes, when a new adjustment is made by the aid of the indicator or by observation of the exhaust. Mechanically operated mixing valves, usually of the "butterfly" type, are used on high-speed engines; these are positive in their

action. The use of separate pumps for supplying air and gas permits of proportioning in the ratio of the pump displacements, the volume delivered being constant, regardless of the pressure or temperature. Many adjustable mixing valves and carbureters are made, in which the mixture strength may be regulated at will. These are necessary where irregularities of pressure or temperature occur, but require close attention for economical results. In the usual type of carbureter or vaporizer, used with gasoline, a constant level of liquid is maintained either by an overflow pipe or by a float. The suction of the engine piston draws air through a nozzle, and the fuel is drawn into and vaporized by the rapidly moving air current. Kerosene cannot be vaporized without heating it: the kerosene carbureter may be jacketed by the engine exhaust, or the liquid may be itself spurted directly into the cylinder at the proper moment, air only being present in the cylinder during compression. The presence of burned gas in the clearance space of the cylinder affects the mixture, retarding the flame propagation. The effect of the mixture strength on allowable compression pressures remains to be considered.

311. Actual Gas Engine Diagram. A typical indicator diagram from a good Otto cycle engine is shown in Fig. 136. The various lines differ somewhat from those established in Art. 288. These differences we now discuss. Figure 137 shows the portion *bcd*e of the diagram in Fig. 136 to an enlarged vertical scale, thus representing the action more clearly. The line *fg* is that of atmospheric pressure, omitted in Fig. 136. We will begin our study of the actual cycle with the *compression line*.



FIG. 136. Arts. 311, 342, 345.— Otto Engine Indicator Diagram.

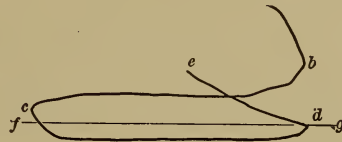

FIG. 137. Arts. 311, 326, 328.— Enlarged Portion of Indicator Diagram.

312. Limitations of Compression. It has been shown that a high degree of compression is theoretically essential to economy. In practice, compression must be limited to pressures (and corresponding temperatures) at which the gases will not ignite of themselves; else combustion will occur before the piston reaches the end of the stroke, and a backward impulse will be given. Gases differ widely as to the temperatures at which they will ignite; hydrogen, for example, inflames so readily that Lucke (21) estimates that the allowable final pressure must be reduced one atmosphere for each 5 per cent of hydrogen present in a mixed gas.

The following are the average final gauge compression pressures recommended by Lucke (22): for *gasoline*, in automobile engines, 45 to 95 lb., in ordinary engines, 60 to 85 lb.; for *kerosene*, 30 to 85 lb.; for *natural gas*, 75 to 130 lb.; for *coal gas* or *carbureted water gas*,

60 to 100 lb.; for producer gas, 100 to 160 lb.; and for blast furnace gas, 120 to 190 lb. The range of compression depends also upon the pressure existing in the cylinder at the beginning of compression; for two-cycle engines, this varies from 18 to 21 lb., and for four-cycle engines, from 12 to 14 lb., both absolute.

The pre-compression temperature also limits the allowable range below the point of self-ignition. This temperature is not that of the entering gases, but it is that of the cylinder contents at the moment when compression begins; it is determined by the amount of heat given to the incoming gases by the hot cylinder walls, and this depends largely upon the thoroughness of the water jacketing and the speed of the engine. This accounts for the rather wide ranges of allowable compression pressures above given. Usual pre-compression temperatures are from 140° to 300° F. "Scavenging" the cylinder with cold air, the injection of water, or the circulation of water in tubes in the clearance space, may reduce this. Usual practice is to thoroughly jacket all exposed surfaces, including pistons and valve faces, and to avoid pockets where exhaust gases may collect. The primary object of jacketing, however, is to keep the cylinder cool, both for mechanical reasons (*e.g.*, for lubrication) and to avoid uncontrollable explosions at the moment when the gas reaches the cylinder.

313. Practical Advantages of Compression. Compression pressures have steadily increased since 1881, and engine efficiencies have increased correspondingly, although the latter gain has been in part due to other causes. Improved methods of ignition have permitted of this increased compression. Besides the thermodynamic advantage already discussed, compression increases the engine capacity. In a non-compressive engine, no considerable range of expansion could be secured without allowing the final pressure to fall too low to give a large work area; in the compressive engine, wide expansion limits may be obtained along with a fairly high terminal pressure. Compression reduces the exposed cylinder surface in proportion to the weight of gas present at maximum temperature, and so decreases the loss of heat to the walls. The decreased proportion of clearance space following the use of compression also reduces the proportion of spent gases to be mixed with the incoming charge.

314. Pressure Rise during Combustion. In Art. 292, the pressure P_b after combustion was assumed. While, for reasons which will appear, any computation of the rise of pressure by ordinary methods is unreliable, the method should be described. Let H denote the amount of heat liberated by combustion, per pound of fuel. Then, Fig. 122, $H = l(T_b - T_e)$, $T_b - T_e = \frac{H}{l}$ and $T_b = \frac{H}{l} + T_e$. But

$$\frac{P_b}{P_e} = \frac{T_b}{T_e} = \frac{H}{lT_e} + 1. \quad \text{Then } P_b - P_e = \frac{P_e H}{lT_e}. \quad \text{But } \frac{P_e}{T_e} = \frac{R}{V_e}, \text{ whence}$$

$$\frac{P_b - P_e}{P_e} = \frac{k - l}{lV_e} = \frac{k - l}{l \left(\frac{P_a}{P_e} \right)^{\frac{1}{\gamma}} V_a}$$

Then

$$P_b - P_e = \frac{H(k-l)}{l \left(\frac{P_d}{P_e}\right)^{\frac{1}{\gamma}} V_d} = \frac{0.402 H}{\left(\frac{P_d}{P_e}\right)^{0.713} V_d}$$

315. Computed Maximum Temperature. Dealing now with the constant volume ignition line of the ideal diagram, let the gas be one pound of pure carbon monoxide, mixed with just the amount of air necessary for combustion (2.48 lb.), the temperature at the end of compression being 1000° absolute, and the pressure 200 lb. absolute. Since the heating value of 1 lb. of CO is 4315 B. t. u., while the specific heat at constant volume of CO₂ is 0.1692, that of N being 0.1727, we have

$$\text{rise in temperature} = \frac{4315}{(1.57 \times 0.1692) + (1.91 \times 0.1727)} = 7265^\circ \text{ F.}$$

The temperature after complete ignition is then 8265° absolute. The pressure is $200 \times \frac{8265}{1000} = 1653$ lb. If the volume increases during ignition, the pressure decreases. Suppose the volume to be doubled, the rise of temperature being, nevertheless, as computed: then the maximum pressure attained is 826.5 lb.

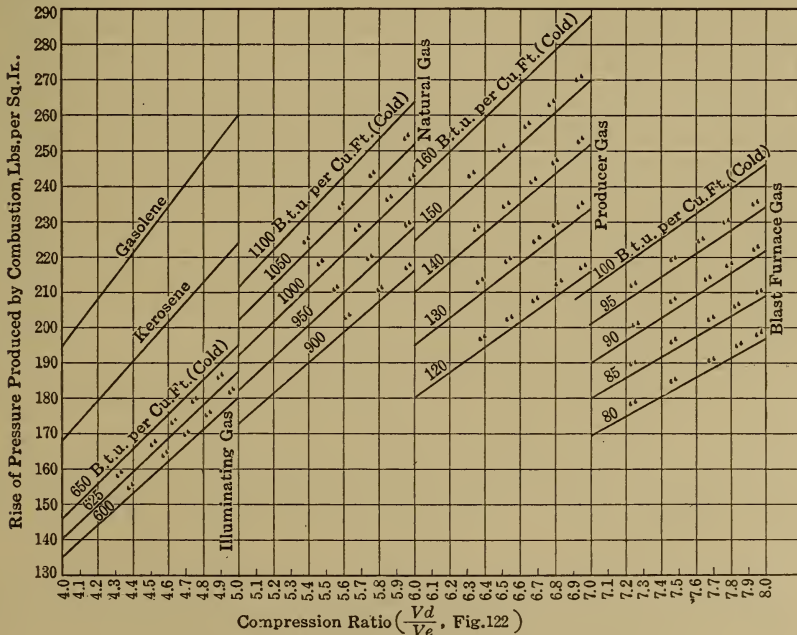

FIG. 137a. Art. 316.—Rise of Pressure in Practice.

316. Actual Maxima. No such temperature as 8265° absolute is attained. In actual practice, the temperature after ignition is usually

about 3500° absolute, and the pressure under 400 lb. The rise of either is less than half of the rise theoretically computed, for the actual air supply, with the actual gas delivered. The discrepancy is least for oil fuels and (mixtures being of proper strength) is greatest for fuels of high heat value. It is difficult to measure the maximum temperature, on account of its extremely brief duration. It is more usual to measure the pressure and compute the temperature. This is best done by a graphical method, as with the indicator. Fig. 137*a* gives the results of a tabulation by Poole of pressure rises obtained in usual practice.

317. Explanation of Discrepancy. There are several reasons for the disagreement between computed and observed results. Charles' law does not hold rigidly at high temperatures; the specific heats of gases are known to increase with the temperature (Meyer found in one case the theoretical maximum temperature to be reduced from 4250° F. to 3330° F. by taking account of the increases in specific heats as determined by Mallard and Le Chatelier); combustion is actually not instantaneous throughout the mass of gas and some increase of volume always occurs; and the temperature is lowered by the cooling effect of the cylinder walls. Still another reason for the discrepancy is suggested in Art. 318.

318. Dissociation. Just as a certain maximum temperature must be attained to permit of combustion, so a certain maximum temperature must not be exceeded if combustion is to continue. If this latter temperature is exceeded, a suppression of combustion ensues. Mallard and Le Chatelier found this "dissociation" effect to begin at about 3200° F. with carbon monoxide and at about 4500° F. with steam. Deville, however, found dissociative effects with steam at 1800° F., and with carbon dioxide at still lower temperatures. The effect of dissociation is to produce, at each temperature within the critical range for the gas in question, a stable ratio of combined to elementary gases,—*e.g.* of steam to oxygen and hydrogen,—which cannot widely vary. No exact relation between specific temperatures and such stable ratio has yet been determined. It has been found, however, that the maximum temperature actually attained by the combustion of hydrogen in oxygen is from 3500° to 3800° C., although the theoretical temperature is about 9000° C. At constant pressure (the preceding figures refer to combustion at constant volume), the actual and theoretical figures are 2500° and 6000° C. respectively. For hydrogen burning in air, the figures are 1830 to 2000°, and 3800° C. Dissociation here steps in to limit the complete utilization of the heat in the fuel. In gas engine practice, the temperatures are so low that dissociation cannot account for all of the discrepancy between observed and computed values; but it probably plays a part. (See Art. 127*b*.)

319. Rate of Flame Propagation. This has been mentioned as a factor influencing the maximum temperature and pressure attained. The speed at which flame travels in an inflammable mixture, if at rest, seldom exceeds 65 ft. per second. If under pressure or agitation, pulsations may be produced, giving rise to "explosion waves," in which the velocity is increased and excessive variations in pressure occur, as combustion is more or less localized (23). Clerk (24), experi-

menting on mixtures of coal gas with air, found maximum pressure to be obtained in minimum time when the proportion of air to gas by volume was 5 or 6 to 1: for pure hydrogen and air, the best mixture was 5 to 2. The Massachusetts Institute of Technology experiments, made with carbureted water gas, showed the best mixture to be 5 to 1; with 86° gasoline, the quickest inflammation was obtained when 0.0217 parts of gasoline were mixed with 1 part of air; with 76° gasoline, when 0.0263 to 0.0278 parts were used.* Grover found the best mixture for coal gas to be 7 to 1; for acetylene, 7 or 8 to 1, acetylene giving higher pressures than coal gas. With coal gas, the weakest ignitable mixture was 15 to 1, the theoretically perfect mixture being 5.7 to 1. The limit of weakness with acetylene was 18 to 1. Both Grover and Lucke (26) have investigated the effect of the presence of "neutrals" (carbon dioxide and nitrogen, derived either from the air, the incoming gases, or from residual burnt gas) on the rapidity of propagation. The re-

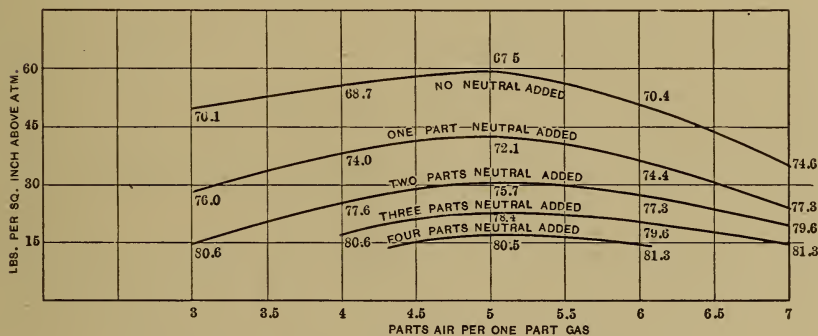

FIG. 138. Art. 319. — Effect of Presence of Neutrals.

(From Hutton's "The Gas Engine," by permission of John Wiley & Sons, Publishers.)

sults of Lucke's study of water gas are shown in Fig. 138. The ordinates show the maximum pressures obtained with various proportions of air and gas. These are highest, for all percentages of neutral, at a ratio of air to gas of 5 to 1; but they decrease as the proportion of neutral increases. The experiments indicate that the speed of flame travel varies widely with the nature of the mixture and the conditions of pressure to which it is subjected. *If the mixture is too weak or too strong, it will not inflame at all.* (See Art. 105a.)

320. Piston Speed. The actual shape of the ideally vertical ignition line will depend largely upon the speed of flame propagation as compared with the speed of the piston. Figure 139, after Lucke, illustrates this. The three diagrams were taken from the same engine under exactly the same conditions, excepting that the speeds in the three cases were 150, 500, and 750 r. p. m. Similar effects may be obtained by varying the mixture (and consequently the flame speed) while keeping the piston speed constant. High compression causes quick ignition. Throt-

* The theoretical ratio of air to C_6H_{14} is 47 to 1.

ting of the incoming charge increases the percentage of neutral from the burnt gases and retards ignition.

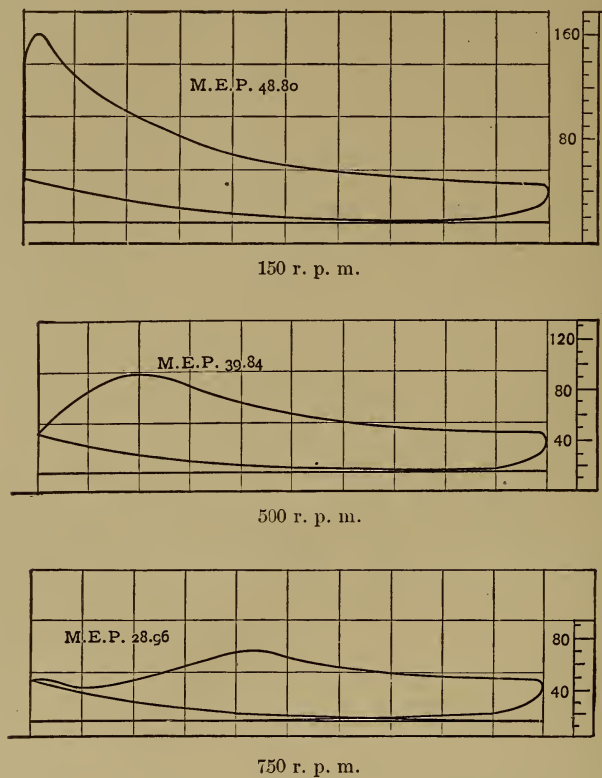

FIG. 139. Art. 320.—Ignition Line as affected by Piston Speed.

(From Lucke's "Gas Engine Design.")

321. Point of Ignition. The spreading of flame is at first slow. Ignition is, therefore, made to occur prior to the end of the stroke, giving a practically vertical line at the end, where inflammation is well under way. Figure 140, from Poole (27), shows the effects of change in the point of ignition. In (a) and (b), ignition was so early as to produce a negative loop on the diagram. This was corrected in (c), but (d) represents a still better diagram. In (e) and (f), ignition was so late that the comparatively high piston speed kept the pressure down, and the work area was small. It is evident that too early a point of ignition causes a backward impulse on the piston, tending to stop the engine. Even though the inertia of the fly wheel carries the piston past its "dead point," a large amount of power is wasted. The same loss of power follows accidental pre-ignition, whether due to excessive compression, contact with hot burnt gases, leakage past piston rings, or other causes. Failure to ignite causes loss of capacity and irregularity

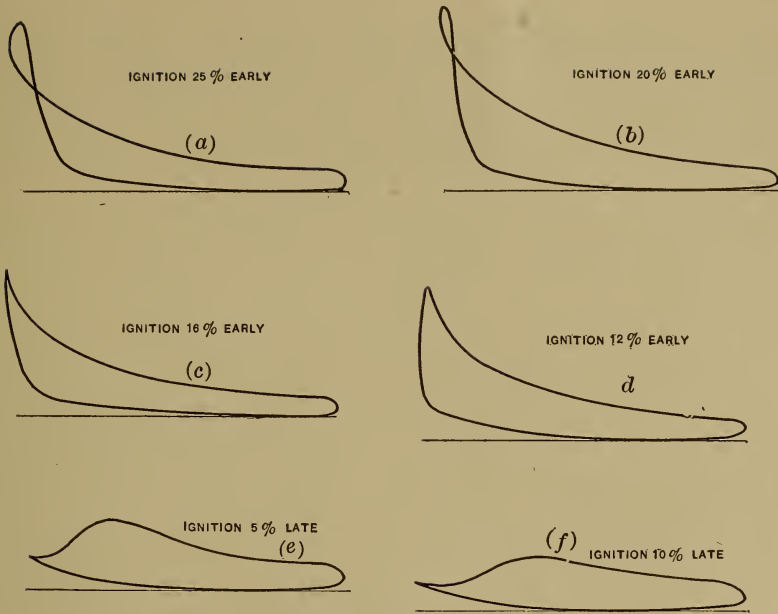

FIG. 140. Art. 321.—Time of Ignition.
(From Poole's "The Gas Engine," by permission of the Hill Publishing Company.)

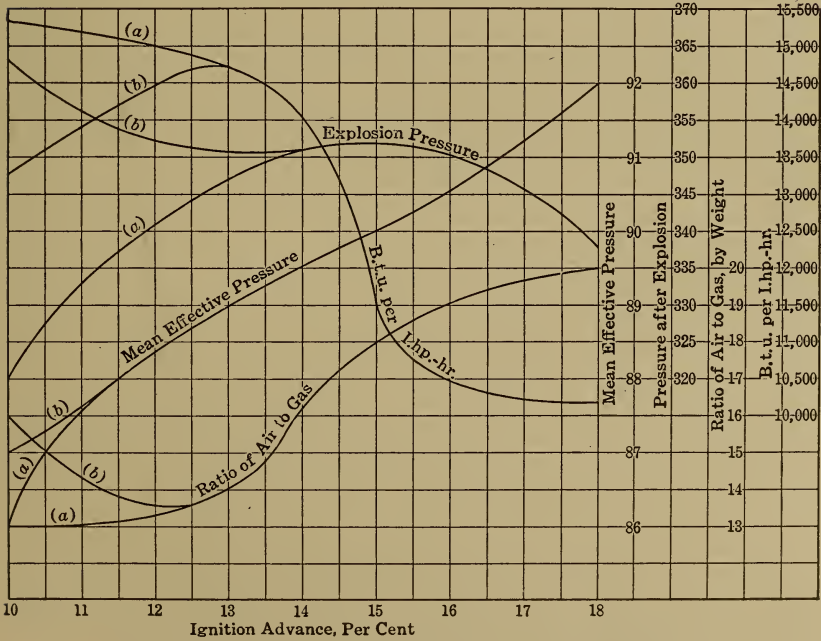

FIG. 140a. Art. 321.—Mixture Strength and Ignition Point.

of speed, but theoretically at least does not affect economy. For reasons already suggested, *light loads* (where governing is effected by throttling the supply) and *weak mixtures call for early ignition*. Fig. 140a, based on tests of a natural gas engine reported by Poole, shows the effect of a simultaneous varying of mixture strength and ignition point. The splitting of each curve at its left-hand end is due to the use of two mixture strengths at 10 per cent ignition advance.

322. Methods of Ignition. An early method for igniting the gas was to use an external flame enclosed in a rotating chamber which at proper intervals opened communication between the flame and the gas. This arrangement was applicable to slow speeds only, and some gas always escaped. In early Otto engines, the external flame with a sliding valve was used at speeds as high as 100 r. p. m. (28). The insertion periodically of a heated plate, once practiced, was too uncertain. The use of an internal flame, as in the Brayton engine, was limited in its application and introduced an element of danger. Self-ignition by the catalytic action of compressed gas upon spongy platinum was not sufficiently positive and reliable. The use of an incandescent wire, electrically heated and mechanically brought into contact with the gas, was a forerunner of modern electrical methods. The "hot tube" method is still in frequent use, particularly in England. This involves the use of an externally heated refractory tube, which is exposed to the gas either intermittently by means of a timing valve, or continuously, ignition being then controlled by adjusting the position of the external flame. In the Hornsby-Akroyd and Diesel engines, ignition is self-induced by compression alone; but external heating is necessary to start these engines.

What is called "automatic ignition" is illustrated in Fig. 151. Here the external vaporizer is constantly hot, because unjacketed. The liquid fuel is sprayed into the vaporizer chamber. Pure air only is taken in by the engine during its suction stroke. Compression of this air into the vaporizer during the stroke next succeeding brings about proper conditions for self-ignition.

323. Electrical Methods. The two modern electrical methods are the "make and break" and "jump spark." In the former, an electric current, generated from batteries or a small dynamo, is passed through two separable contacts located in the cylinder and connected in series with a spark coil. At the proper instant, the contacts are separated and a spark passes between them. In the jump spark system, an induction coil is used and the igniter points are stationary and from 0.03 to 0.05 in. apart. A series of sparks is thrown between them when the primary circuit is closed, just before the end of the compression stroke. Occasionally there are used more than one set of igniter points.

324. Clearance Space. The combustion chamber formed in the clearance space must be of proper size to produce the desired final pressure. A common ratio to piston displacement is 30 per cent. Hutton has shown (29) that the limits for best results may range easily from 8.7 to 56 per cent (Art. 332).

325. Expansion Curve. Slow inflammation has been shown to result in a decreased maximum pressure after ignition. Inflammation occurring during expansion as the result of slow spreading of the flame is called "after burning." Ideally, the expansion curve should be adiabatic; actually it falls in many cases above the air adiabatic, $pv^{1.402} = \text{constant}$, although it is known that during expansion from 30 to 40 per cent of the total heat in the gas is being carried away by the jacket water. Figure 141 represents an extreme case; after-burning has made the expansion line almost horizontal, and some unburnt gas is being discharged to the exhaust. Those who hold to the dissociation theory would explain this line on the ground that the gases dissociated during combustion are gradually combining as the temperature falls; but actually, the temperature is not falling, and the effect which we call after burning is most pronounced with weak mixtures and at such low temperatures as do not permit of any considerable amount of dissociation. Practically, dissociation has the same effect as an increasing specific heat at high temperature. It affects the *ignition line* to some extent; but the shape of the *expansion line* is to a far greater degree determined by the slow inflammation of the gases. The effect of the transfer of heat between the fluid and the cylinder walls is discussed in Art. 347. The actual exponent of the expansion curve varies from 1.25 in large engines to 1.38 in good small engines, occasionally, however, rising as high as 1.55. The compression curve has usually a somewhat higher exponent. The adiabatic exponent for a mixture of hydrocarbon gases is lower than that for air or a perfect gas; and in many cases the *actual* adiabatic, plotted for the gases used, would be *above* the determined expansion line, as should normally be expected, in spite of after burning. The presence of explosion waves (Art. 319) may modify the shape of the expansion curve, as in Fig. 142. The equivalent curve may be plotted as a mean through the oscillations. Care must be taken not to confuse these vibrations with those due to the inertia of the indicating instrument.



FIG. 141. Art. 325. — After Burning.

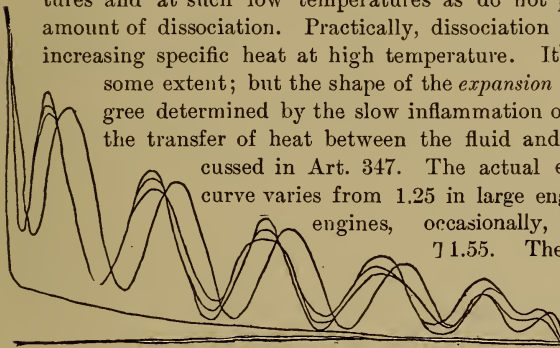

FIG. 142. Art. 325. — Explosion Waves.

for air or a perfect gas; and in many cases the *actual* adiabatic, plotted for the gases used, would be *above* the determined expansion line, as should normally be expected, in spite of after burning. The presence of explosion waves (Art. 319) may modify the shape of the expansion curve, as in Fig. 142. The equivalent curve may be plotted as a mean through the oscillations. Care must be taken not to confuse these vibrations with those due to the inertia of the indicating instrument.

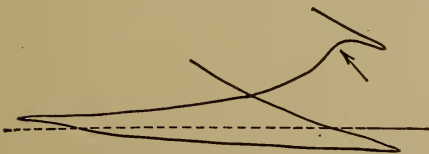

FIG. 143. Art. 326. — Delayed Exhaust Valve Opening.

valve-actuating gear, and the tendency of this is to vary the instant of opening or closing the inlet or the exhaust valve. The effect of delayed opening of the latter is shown in Fig. 143; that of an inadequate exhaust passage, in Fig. 144. An early opening of the exhaust valve may cause loss also, as in Fig. 145. There

326. The Exhaust Line. This is shown to an enlarged vertical scale as *bc*, Fig. 137. "Low spring" diagrams of this form are extremely useful. As engines wear, more or less "lost motion" becomes present in the

is always a loss of this kind, more or less pronounced: the expansion ratio is never quite equal to the compression ratio. The exhaust valve begins to open

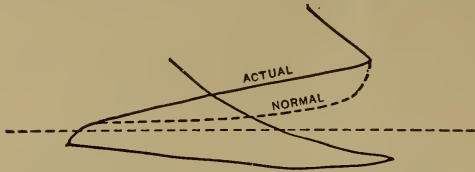

FIG. 144. Art. 326.—Throttled Exhaust Passages.

when the expansion stroke is only from 80 to 93 per cent completed. In multiple cylinder engines having common exhaust and suction mains, early exhaust from one cylinder may produce a rise of pressure during the latter part of the exhaust stroke

of another. Obstructions to suction and discharge movements of gas are commonly classed together as “fluid friction.” This may in small engines amount to as much as 30 per cent of the power developed. In good engines of large or moderate size, it should not exceed 6 per cent. It increases, proportionately, at light loads; and possibly absolutely as well if governing is effected by throttling the charge.

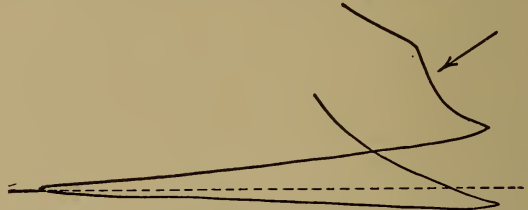

FIG. 145. Art. 326.—Exhaust Valve Opening too Early.

327. Scavenging. To avoid the presence of burnt gases in the clearance space, and their subsequent mingling with the fresh charge, “scavenging,” or sweeping out these gases from the cylinder, is sometimes practiced. This may be accomplished by means of a separate air pump, or by adding two idle strokes to the four strokes of the Otto cycle. In the Crossley engines, the air admission valve was opened before the gas valve, and before the termination of the exhaust stroke. By using a long exhaust pipe, the gases were discharged in a rather violent puff, which produced a partial vacuum in the cylinder. This in turn caused a rush of air into the clearance space, which swept out the burnt gases by the time the piston had reached the end of its stroke. Scavenging decreases the danger of missing ignitions with weak gas, tends to prevent pre-ignition, and appears to have reduced the consumption of fuel.

328. The Suction Stroke. This also is shown in Fig. 137, line *cd*. The effect of late opening of the valve is shown in Fig. 146; that of an obstructed passage or of throttling the supply, in Fig.

147. If the opening is too early, exhaust gases will enter the supply pipe. If closure is too early, the gas will expand during the remainder of the suction stroke, but the net work lost is negligible; if too late, some gas will be discharged back to the supply pipe during the beginning of the compression stroke,



FIG. 146. Art. 328.—Delayed Opening of Suction Valve.

as in Fig. 148. Excessive obstruction in the suction passages decreases the capacity of the engine, in a way already suggested in the study of air compressors (Art. 224).

329. Diagram Factor. The discussion of Art. 309 to Art. 328 serves to show why the work area of any *actual diagram* must always be less than that of the *ideal diagram* for the same cylinder, as given in Fig. 122. The ratio of the two is called the **diagram factor**.

The area of the ideal card would constantly increase as compression increased; that of the actual card soon reaches a limit in this respect; and, consequently, in general, the diagram factor decreases as compression increases. Variations in excellence of design are also responsible for variations of diagram factor.

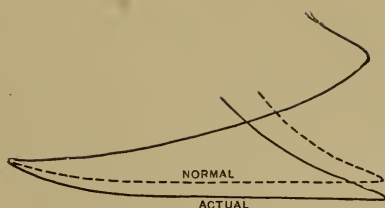

FIG. 147. Art. 328. — Throttled Suction.



FIG. 148. Art. 328. — Late Closing of Suction Valve.

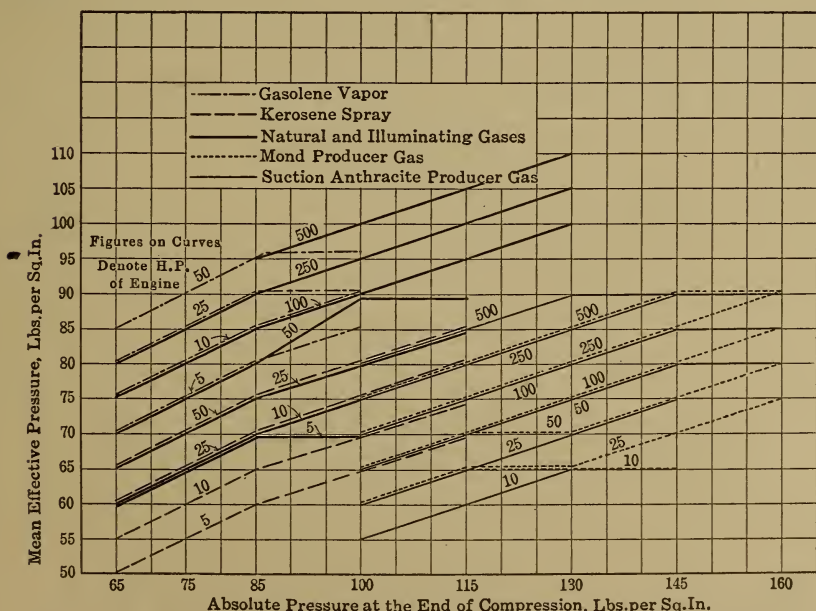

FIG. 148a. Art. 329. — Maximum Mean Effective Pressures Realized in Practice.

In the best recorded tests, its value has ranged from 0.38 to 0.59; in ordinary practice, the values given by Lucke (30) are as follows: for *kerosene*, if previously vaporized and compressed, 0.30 to 0.40, if injected on a hot tube, 0.20; for *gasoline*, 0.42 to 0.50; for *producer gas*, 0.40 to 0.56; for *coal gas*, 0.45; for *carbureted water gas*, 0.45; for *blast furnace gas*, 0.30 to 0.48; for *natural gas*, 0.40 to 0.52. These figures are for four-cycle engines. For *two-cycle* engines, usual values are about 20 per cent less. Figure 149 shows on the PV and entropy planes an actual indicator diagram with the corresponding ideal cycle.

Some of the highest mean effective pressures obtained in practice with various fuels, tabulated by Poole, have been charted in Fig. 148a.

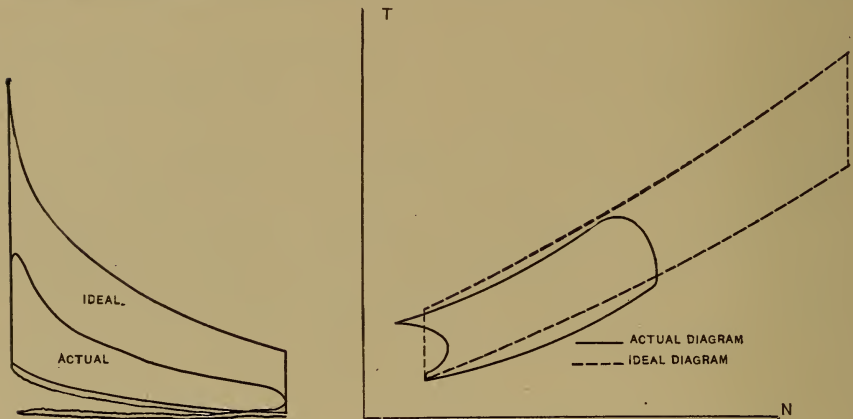

FIG. 149. Art. 329. — Actual and Ideal Gas Engine Diagrams.

MODIFIED ANALYSIS

329 a. Specific Heats Variable. Suppose $k = c + bt$, $l = a + bt$, $R = k - l = c - a$. For a differential adiabatic expansion

$$\begin{aligned}
 ldt &= -pdv, \\
 \frac{(a + bt)dt}{t} &= -R \frac{dv}{v}, \\
 \frac{adt}{t} + bdt &= -R \frac{dv}{v}. \tag{1}
 \end{aligned}$$

Also, from $pv = Rt$, $pdv + vdp = Rdt$, $\frac{dv}{v} + \frac{dp}{p} = \frac{dt}{t}$; whence

$$\begin{aligned}
 a \frac{dv}{v} + a \frac{dp}{p} + bdt &= -R \frac{dv}{v}, \\
 (a + R) \frac{dv}{v} + a \frac{dp}{p} + bdt &= 0,
 \end{aligned}$$

$$\begin{aligned} (a + R) \log_e v + a \log_e p + bt &= \text{constant}, \\ c \log_e v + a \log_e p + bt &= \text{constant}, \\ \frac{c}{a} \log_e v + \log_e p + \frac{bt}{a} &= \text{constant}, \\ p v^{\frac{c}{a}} e^{\frac{bt}{a}} &= \text{constant}, \end{aligned}$$

where e is the Napierian logarithmic base.

Between given limits, the approximate value of n may be obtained as follows: from Equation (1),

$$\begin{aligned} a \log_e \frac{t_2}{t_1} + b(t_2 - t_1) &= -R \log_e \frac{v_2}{v_1}, \\ a \log_e \frac{p_2}{p_1} + a \log_e \frac{v_2}{v_1} + b(t_2 - t_1) &= -R \log_e \frac{v_2}{v_1}, \\ a \log_e \frac{p_2}{p_1} + (a + R) \log_e \frac{v_2}{v_1} &= b(t_1 - t_2). \end{aligned} \tag{2}$$

If we assume an equation in the form $p_1 v_1^n = p_2 v_2^n$ to be possible, then

$$\log_e \frac{p_1}{p_2} = n \log_e \frac{v_2}{v_1}.$$

Substituting in Equation (2),

$$\begin{aligned} (-an + a + R) \log_e \frac{v_2}{v_1} &= b(t_1 - t_2), \\ (-an + c) \log_e \frac{v_2}{v_1} &= b(t_1 - t_2), \\ n &= \frac{c}{a} - \frac{b(t_1 - t_2)}{a \log_e \frac{v_2}{v_1}}. \end{aligned} \tag{3}$$

The external work done during the expansion is

$$\begin{aligned} - \int l dt &= - \int (a + bt) dt = -a(t_2 - t_1) - \frac{b}{2}(t_2^2 - t_1^2), \text{ or} \\ &\frac{p_1 v_1 - p_2 v_2}{n - 1}, \end{aligned}$$

where n has the value given in Equation (3).

We may find a simple expression for n by combining these equations:

$$\begin{aligned} \frac{p_1 v_1 - p_2 v_2}{n - 1} &= R \frac{t_1 - t_2}{n - 1} = a(t_1 - t_2) + \frac{b}{2}(t_1 - t_2)(t_1 + t_2), \\ \frac{R}{n - 1} &= a + \frac{b}{2}(t_1 + t_2), \\ n &= 1 + \frac{R}{a + \frac{b}{2}(t_1 + t_2)}. \end{aligned} \tag{4}$$

The efficiency of the Otto cycle $debf$, Fig. 122, may now be written

$$\begin{aligned} \frac{H_{eb} - H_{fd}}{H_{eb}} &= 1 - \frac{\int_a^f (a + bt) dt}{\int_e^b (a + bt) dt} \\ &= 1 - \frac{a(t_f - t_a) + \frac{b}{2}(t_f^2 - t_a^2)}{a(t_b - t_e) + \frac{b}{2}(t_b^2 - t_e^2)}, \end{aligned}$$

in which $\frac{b}{a}(t_f - t_a + t_e - t_b) = \log_e \left(\frac{p_b p_d}{p_e p_f} \right) = \log_e \left(\frac{t_b t_d}{t_e t_f} \right)$ — a relation obtained by dividing the equation of the path bf by that of the path ed .

Following the method of Art. 169, the *gain of entropy* between the states a and b is, for example,

$$\begin{aligned} n_{ab} &= n_{ac} + n_{cb} = \int_a^c \frac{ldt}{t} + \int_c^b \frac{kdt}{t}, \\ &= \int_a^c (a + bt) \frac{dt}{t} + \int_c^b (c + bt) \frac{dt}{t}, \\ &= a \log_e \frac{t_c}{t_a} + b(t_c - t_a) + c \log_e \frac{t_b}{t_c} + b(t_b - t_c), \\ &= a \log_e \frac{p_b}{p_a} + c \log_e \frac{v_b}{v_a} + b(t_b - t_a). \end{aligned} \tag{5}$$

If we apply an equation in this general form to each of the constant volume paths eb , df , Fig. 122, we find

$$\begin{aligned} a \log_e \frac{t_b}{t_e} + b(t_b - t_e) &= a \log_e \frac{t_f}{t_d} + b(t_f - t_d), \\ \log_e \left(\frac{t_b t_d}{t_e t_f} \right) &= \frac{b}{a}(t_f - t_d - t_b + t_e), \end{aligned}$$

as already obtained.

329 b. Application of the Equations. The expression $p v^{\frac{c}{a}} e^{\frac{bt}{a}} = \text{constant}$ is exceedingly cumbersome in application excepting as t is employed independently. If t is to be assumed, however, we may write

$$\begin{aligned} \log_e p + \frac{c}{a} \log_e v + \frac{bt}{a} &= \log_e \text{constant}, \\ \log_e p + \frac{c}{a} (\log_e R + \log_e t - \log_e p) + \frac{bt}{a} &= \log_e \text{constant}, \\ \frac{a-c}{a} \log_e p + \frac{c}{a} (\log_e R + \log_e t) + \frac{bt}{a} &= \log_e \text{constant}. \end{aligned}$$

Consider one pound of air at the absolute pressure of 100 lb. per square inch and a volume of 1 cu. ft. Let $k=0.23327+0.0000265 t$, $l=0.1620+0.0000265 t$. We find

$$t_1 = \frac{p_1 v_1}{R} = \frac{100 \times 144 \times 1}{53.36} = 270.$$

$$p v^a e^{\frac{bt}{a}} = 100 \times 144 \times 1 \times 2.7183^{0.044} = 15030.$$

$$\frac{a-c}{a} = \frac{0.1620 - 0.23327}{0.1620} = -0.441; \quad \frac{c}{a} = \frac{0.23327}{0.162} = 1.44; \quad \log_e R = 3.97.$$

Let $t_2=200$. Then $\frac{bt_2}{a} = 0.0327$, $\log_e t_2 = 5.3$, $\frac{c}{a}(\log_e R + \log_e t_2) = 13.32$,

$\frac{a-c}{a} \log_e p_2 = \log_e 15030 - 13.32 - 0.0327 = 9.61 - 13.35 = -3.74$, $\log_e p_2 = 8.48$, $\log p_2 = 3.685$, $p_2 = 4845$ lb. per square foot = 33.63 lb. per square inch. Also

$$v_2 = \frac{Rt_2}{p_2} = \frac{53.36 \times 200}{4845} = 2.21.$$

For $y = 1.44 = \left(\frac{0.23327}{0.162}\right)$ we should have had

$$\frac{p_2}{p_1} = \left(\frac{t_2}{t_1}\right)^{\frac{y}{y-1}} = \left(\frac{200}{270}\right)^{3.27},$$

$$\log p_2 = 2 + (3.27 \times -0.131) = 1.571,$$

$$p_2 = 37.23 \text{ lb. per square inch,}$$

and $v_2 = \frac{Rt_2}{p_2} = \frac{53.36 \times 200}{37.23 \times 144} = 1.99$. Proceeding in this way, we plot the two curves of Fig. 122 *b*. The y curve is the steeper of the two, and for expansion to a given lower temperature reaches a point of considerably less volume.

By Equation (3), for the upper of the two curves, between

$$p_1 = 100, \quad t_1 = 270, \quad v_1 = 1, \quad \text{and} \quad p_2 = 3.32, \quad t_2 = 100, \quad v_2 = 11.14,$$

$$n = 1.44 - \frac{0.0000265 \times 170}{0.162 \times 2.3 \log 11.14} = 1.44 - \frac{0.00451}{0.39} = 1.43,$$

the curve being somewhat less steep than the y curve. This value of n (1.43) will be found to fit the whole expansion with reasonable accuracy.

Also, by Equation (4),

$$n = 1 + \frac{53.36 \div 778}{0.162 + \left(\frac{0.0000265}{2} \times 370 \right)} = 1.41,$$

a fairly close check value. If we take p_1 at 50 lb. per square inch, and t_1 at 135° absolute, instead of the conditions given, we have,

$$pv^{\frac{c}{a}} e^{\frac{bt}{a}} = 50 \times 144 \times 1 \times 2.7183^{0.022} = 7360.$$

If we let $t_2 = 100^\circ$, $\frac{bt_2}{a} = 0.01635$, $\log_e t_2 = 4.6$, $\frac{c}{a} (\log_e R + \log_e t_2) = 12.3$,

$\frac{a-c}{a} \log_e p_2 = \log_e 7360 - 12.3 - 0.01635 = -3.42$, $\log_e p_2 = 7.75$, $\log p_2 = 3.37$,

$$p_2 = 2342, v_2 = \frac{53.36 \times 100}{2342} = 2.278,$$

$$n = 1.44 - \frac{0.0000265 \times 35}{0.162 \times 2.3 \log 2.278} = 1.43,$$

or

$$n = 1 + \frac{53.36 \div 778}{0.162 + \left(\frac{0.0000265}{2} \times 235 \right)} = 1.42.$$

The value of n is thus about the same for this curve as for that formerly considered, and (approximately), in Fig. 122,

$$\frac{t_b}{t_e} = \frac{t_f}{t_d}.$$

If this relation were exact, the efficiency of an Otto cycle would be expressed by the same formula as that which holds when the specific heats are constant. In Fig. 124, the efficiency of the strip cycle $qvwp$ is

$$\frac{qvwp}{yvwx} = \frac{t_{vw} - t_{qp}}{t_{vw}} = 1 - \frac{t_{qp}}{t_{vw}},$$

and if $\frac{t_e}{t_d} = \frac{t_v}{t_a} = \frac{t_w}{t_p} = \frac{t_b}{t_f}$, etc., the efficiency of the whole cycle $defb$ is

$$1 - \frac{t_d}{t_e} = 1 - \frac{t_f}{t_b} = \frac{t_e - t_d}{t_e} = \frac{t_b - t_f}{t_b}.$$

For a path of constant volume, in Equation (5), $\frac{v_b}{v_a} = 1$, $\frac{p_b}{p_a} = \frac{t_b}{t_a}$, and the gain of entropy is

$$a \log_e \frac{t_b}{t_a} + b(t_b - t_a), \text{ or}$$

$$\int_{t_a}^{t_b} l \frac{dt}{t} = \int_{t_a}^{t_b} (a + bt) \frac{dt}{t} = a \log_e \frac{t_b}{t_a} + b(t_b - t_a). \quad (6)$$

In the case under consideration, $t_b = 270$, $t_a = 135$, $a = 0.162$, $b = 0.0000265$, so that Equation (6) gives for the path eb ,

$$0.162 \times 2.3 \log \frac{270}{135} + (0.0000265 \times 135) = 0.1122 + 0.0036 = 0.1158.$$

If in Fig. 122 the temperature at d is 100° , we may write

$$\begin{aligned} 0.1158 &= 0.162 \times 2.3 \log \frac{t_f}{100} + 0.0000265(t_f - 100) \\ &= 0.372 \log t_f - 0.744 + 0.0000265 t_f - 0.00265, \\ \log t_f + 0.0000712 t_f &= 2.32, \end{aligned}$$

from which t_f is, nearly, $\log^{-1} 2.32$, and $t_f = 200^\circ$, about. In expanding from 270° to 200° , the volume increased from 1.0 to 2.21; in expanding from 135° to 100° , it increased from 1.0 to 2.28. We have computed the change of entropy from $p = 50$, $v = 1$, $t = 135$, to $p = 100$, $v = 1.0$, $t = 270$, as 0.1158. This must equal the change from $p = \frac{2342}{144} = 16.85$, $t = 100$, $v = 2.28$, to $p = 33.6$, $v = 2.28$, $t = ?$ Now for $p = 33.6$, $v = 2.21$, it was found that $t = 200$. Adiabatic expansion from this point to the *greater* volume 2.28 means that t_f must be slightly *less* than 200° ; but a very slight change in temperature produces a large change in volume since the isothermals and the adiabatics nearly coincide.

GAS ENGINE DESIGN

330. Capacity. The work done per stroke may readily be computed for the ideal cycle, as in Art. 293. This may be multiplied by the diagram factor to determine the probable performance of an actual engine. To develop a given power, the number of cycles per minute must be established. Ordinary piston speeds are from 450 to 1000 ft. per minute, usually lying between 550 and 800 ft., the larger engines having the higher speeds. The stroke ranges from 1.0 to 2.0 times the diameter, the ratio increasing, generally, with the size of the engine. A gas engine has no overload capacity, strictly speaking, since all of the factors entering into the determination of its capacity are intimately related to its efficiency. It can be given a margin of capacity by making it larger than the computations indicate as necessary, but this or any other method involves a considerable sacrifice of the economy at normal load.

331. Mean Effective Pressure. Since in an engine of given size the extreme volume range of the cycle is fixed, the *mean net ordinate of the work area measures the capacity*. The quotient of the cycle area by the volume range gives what is called the *mean effective pressure* (m. e. p.). In Fig. 122, it is $ebfd \div (V_d - V_e)$. We then write m. e. p. = $W \div (V_d - V_e)$; but from Art. 295, $W = Q \left[1 - \left(\frac{P_d}{P_e} \right)^{\frac{y-1}{y}} \right]$; Q

being the gross quantity of heat absorbed in the cycle. Then, in proper units, without allowance for diagram factor,

$$\text{m. e. p.} = \frac{Q \left[1 - \left(\frac{P_d}{P_e} \right)^{\frac{y-1}{y}} \right]}{V_d - V_e}.$$

332. Illustrative Problem. To determine the cylinder dimensions of a four-cycle, two-cylinder, double-acting engine of 500 hp., using producer gas (assumed to contain CO, 39.4; N, 60; H, 0.6; parts in 100 by weight) (Art. 285), at 150 r. p. m. and a piston speed of 325 ft. per minute.

We assume (Fig. 150), $P_1 = 12$, $P_2 = 144.7$, $T_1 = 200^\circ \text{ F.}$, and diagram factor = 0.48 (Arts 312, 329).

Since $P_1 V_1^y = P_2 V_2^y$, $\frac{V_1}{V_2} = \left(\frac{P_2}{P_1} \right)^{\frac{1}{y}} = \left(\frac{144.7}{12} \right)^{0.713} = 5.9$. Let the piston displacement $V_1 - V_2 = D$. Then $V_2 = 0.2045 D$ and $V_1 = 1.2045 D$. The clearance is $\frac{V_2}{D} = 0.2045$ (Art. 324)*. Also $T_2 = \frac{T_1 P_2 V_2}{P_1 V_1} = \frac{659.6 \times 144.7 \times 0.2045}{12 \times 1.2045} = 1357^\circ$

absolute. The heat evolved per pound of the mixed gas (taking the calorific value of hydrogen burned to steam as 53,400) is $(0.394 \times 4315) + (0.006 \times 53,400) = 2021 \text{ B. t. u.}$ The products of combustion consist of $\frac{44}{3} \times 0.394 = 0.619 \text{ lb. of CO}_2$ (specific heat = 0.1692), $0.006 \times 9 = 0.054 \text{ lb. of H}_2\text{O}$ (steam, specific heat 0.37), and $\frac{7}{3}$ $(0.619 - 0.394) = 0.751 \text{ lb. of N}$ accompanying the oxygen introduced to burn the CO, with $(0.054 - 0.006) \frac{7}{3} = 0.1607 \text{ lb. of N}$ accompanying the oxygen introduced to burn the H; and 0.60 lb. of N originally in the gas, making a total of 1.5117 lb. of N (specific heat 0.1727). To raise the temperature of these constituents 1° F. at constant volume requires $(0.619 \times 0.1692) + (0.054 \times 0.37) + (1.5117 \times 0.1727) = 0.3849 \text{ B. t. u.}$ The rise in temperature $T_3 - T_2$ is then $2021 \div 0.3849 = 5260^\circ$, and $T_3 = 5260 + 1357 = 6617^\circ$ absolute. Then

$$P_3 = P_2 \frac{T_3}{T_2} = 144.7 \frac{6617}{1357} = 709,$$

and

$$P_4 = P_1 \frac{P_3}{P_2} = 12 \frac{709}{144.7} = 58.7.$$

* While the use of a "blanket" diagram factor as in this illustration may be justified, in any actual design the clearance at least must be ascertained from the actual exponent of the compression curve. The design as a whole, moreover, would better be based on special assumptions as in Problem 15, (b), page 197.

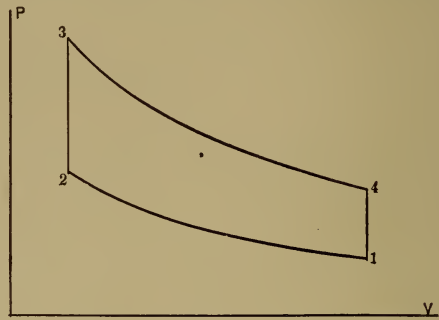

FIG. 150. Arts. 332-335. — Design of Gas Engine.

The work per cycle is

$$\frac{P_3V_3 - P_4V_4 - P_2V_2 + P_1V_1}{y - 1}$$

$$= 144 \times 0.48 D \left[\frac{(709 \times 0.2045) - (58.7 \times 1.2045) - (144.7 \times 0.2045) + (12 \times 1.2045)}{0.402} \right]$$

$$= 10,080 D \text{ foot pounds.}$$

In a two-cylinder, four-cycle, double-acting engine, all of the strokes are working strokes; the foot-pounds of work per stroke necessary to develop 500 hp. are $\frac{33000 \times 500}{2 \times 150} = 55,000$. The necessary piston displacement per stroke, D , is $55,000 \div 10,080 = 5.46$ cu. ft. The *stroke* is $825 \div (2 \times 150) = 2.75$ ft. or 33 in. The piston area is then $5.46 \div 2.75 = 1.985$ sq. ft. or 285.5 sq. in. The area of the water-cooled tail rod may be about 33 sq. in., so that the cylinder area should be $285.5 + 33 = 318.5$ sq. in. and its *diameter* consequently 20.14 in.

333. Modified Design. In an actual design for the assumed conditions, *over-load capacity* was secured by assuming a load of 600 hp. to be carried with 20 per cent excess air in the mixture. (At theoretical air supply, the power developed should then somewhat exceed 600 hp.) The air supply per pound of gas is now

$$[(0.394 \times \frac{1}{2}) + (0.006 \times 8)] \frac{1.2}{2.3} \times 1.2 = 1.422 \text{ lb.}$$

Of this amount, $0.23 \times 1.422 = 0.327$ lb. is oxygen. The products of combustion are $\frac{4}{3} \times 0.394 = 0.619$ lb. CO_2 , $0.006 \times 9 = 0.054$ lb. H_2O , $(1.422 - 0.327) + 0.60 = 1.693$ lb. N, and $0.327 - (\frac{1}{3} \times 0.394) - (8 \times 0.006) = 0.054$ lb. of excess oxygen; a total of 2.422 lb. The rise in temperature $T_3 - T_2$ is

$$\frac{2021}{(0.619 \times 0.1692) + (0.054 \times 0.37) + (1.693 \times 0.1727) + (0.054 \times 0.1551)} = 4760^\circ.$$

Then $T_3 = 4760 + 1357 = 6117^\circ$ absolute,

$$P_3 = P_2 \frac{T_3}{T_2} = 144.7 \frac{6117}{1357} = 655, \quad P_4 = P_1 \frac{P_3}{P_2} = 12 \frac{655}{144.7} = 54.2,$$

and the work per cycle is

$$144 \times 0.48 D \left[\frac{(655 \times 0.2045) - (54.2 \times 1.2045) - (144.7 \times 0.2045) + (12 \times 1.2045)}{0.402} \right]$$

$$= 9150 D \text{ foot-pounds.}$$

The piston displacement per stroke is $\frac{600 \times 33000}{2 \times 150 \times 9150} = 7.21$ cu. ft., the *cylinder* area is $(7.21 \div 2.75)144 + 33 = 410$ sq. in., and its *diameter* 22.83 in. The cylinders were actually made $23\frac{1}{2}$ by 33 in., the gas composition being independently assumed.

334. Estimate of Efficiency. To determine the probable efficiency of the engine under consideration: each pound of working substance is supplied with 1.422 lb. of air. Multiplying the weights of the constituents by their respective specific volumes, we obtain as the volume of mixture per pound of gas, 31.33 cu. ft. at 14.7 lb. pressure and 32° F., as follows:—

$$\begin{aligned}
 \text{CO, } & 0.394 \times 12.75 = 5.01 \\
 \text{H, } & 0.006 \times 178.83 = 1.07 \\
 \text{N, } & 0.600 \times 12.75 = 7.65 \\
 \text{Air, } & 1.422 \times 12.387 = \frac{17.60}{31.33}
 \end{aligned}$$

At the state 1, Fig. 150, $T_1 = 659.6$, $P_1 = 12$, whence

$$V_1 = \frac{T_1 P_0 V_0}{P_1 T_0} = \frac{659.6 \times 14.7 \times 31.33}{12 \times 491.6} = 51.2.$$

The piston displaces $7.21 \times 300 = 2163$ cu. ft. of this mixture per minute. The heat taken in per minute is then $2021 \times (2163 \div 51.2) = 85,200$ B. t. u. The work done per minute is $\frac{600 \times 33000}{778} = 25,500$ B. t. u. The efficiency is then $25,500 \div 85,200 = 0.299$.

An actual test of the engine gave 0.282, with a load somewhat under 600 hp. The Otto cycle efficiency is $\frac{1357 - 659.6}{1357} = 0.516$.*

335. Automobile Engine. To ascertain the probable capacity and economy of a four-cylinder, four-cycle, single-acting gasoline engine with cylinders $4\frac{5}{8}$ by 5 in., at 1500 r. p. m.

In Fig. 150, assume $P_1 = 12$, $P_2 = 84.7$, $T_1 = 70^\circ$ F., diagram factor, 0.375 (Arts. 312, 329). Assume the heating value of gasoline at 19,000 B. t. u., and its composition as C_6H_{14} : its vapor density as 3.05 (air = 1.). Let the theoretically necessary quantity of air be supplied.

The engine will give two cycles per revolution. Its active piston displacement is then $\frac{0.7854 \times (4\frac{5}{8})^2 \times 5}{1728} \times 3000 = 145.5$ cu. ft. per minute, which may be represented as $V_1 - V_2$, Fig. 150. We now find

$$\frac{V_2}{V_1} = \left(\frac{12}{84.7}\right)^{0.713} = 0.2495; \quad V_2 = 0.2495 V_1; \quad 0.7505 V_1 = 145.5; \quad V_1 = 194; \quad V_2 = 48.5;$$

$$\text{Clearance} = \frac{48.5}{145.5} = 0.334 \text{ (Art. 324); } \quad T_2 = \frac{84.7 \times 48.5 \times 529.6}{12 \times 194} = 936^\circ \text{ absolute.}$$

To burn one pound of gasoline there are required 3.53 lb. of oxygen, or 15.3 lb. of air. For one cubic foot of gasoline, we must supply $3.05 \times 15.3 = 46.6$ cu. ft. of air. The 145.5 cu. ft. of mixture displaced per minute must then consist of

* The actual efficiency will always be less than the product of the Otto cycle efficiency by the diagram factor. Thus, let the actual cycle be described as 1234, Fig. 150, and let the corresponding ideal cycle be 123'4'. The efficiencies are, respectively,

$$\frac{1234}{l(T_3 - T_2)} \quad \text{and} \quad \frac{123'4'}{l(T_3' - T_2)}$$

The quotient $1234 \div 123'4' =$ the diagram factor. Then write

$$\frac{123'4'}{l(T_3' - T_2)} \times \text{diagram factor} \times M = \frac{1234}{l(T_3 - T_2)}$$

$$M = \frac{T_3' - T_2}{T_3 - T_2} > 1.0.$$

145.5 ÷ 47.6 = 3.06 cu. ft. of gasoline and 142.44 cu. ft. of air, at 70° F. and 12 lb. pressure. The specific volume of air at this state is $\frac{529.6 \times 14.7 \times 12.387}{491.6 \times 12} = 16.38$ cu. ft.; that of gasolene is $16.38 \div 3.05 = 5.37$ cu. ft. The weight of gasoline used per minute is then $3.06 \div 5.37 = 0.571$ lb. The heat used per minute is $0.571 \times 19,000 = 10,840$ B. t. u. The combustion reaction may be written

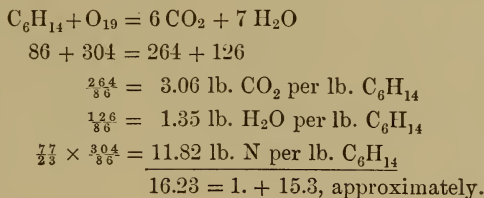

The heat required to raise the temperature of the products of combustion 1° F. is $[(3.06 \times 0.1692) + (1.35 \times 0.37) + (11.82 \times 0.1727)] 0.571 = 1.746$ B. t. u. per minute. The rise in temperature $T_3 - T_2$ is then $10,840 \div 1.746 = 6210^\circ$, $T_3 = 6210 + 936 = 7146^\circ$ absolute, $P_3 = 84.7 \frac{7146}{936} = 648$, $P_4 = 12 \frac{648}{84.7} = 91.8$, and the work per minute is $0.375 \times 144 \left[\frac{(648 \times 48.5) - (91.8 \times 194) - (84.7 \times 48.5) + (12 \times 194)}{0.402} \right] = 1,590,000$ foot-pounds. This is equivalent to $\frac{1,590,000}{778} = 2047$ B. t. u. per minute or to $\frac{1,590,000}{33,000} = 48$ horse power. The efficiency is $2047 \div 10,840 = 0.19$. In an automobile running at 50 miles per hour, this would correspond to $50 \div (0.571 \times 60) = 1.46$ miles run per pound of gasoline. In practice, the air supply is usually incorrect, and the power and economy less than those computed.

It is obvious that with a given fuel, the diagram factor and other data of assumption are virtually fixed. An approximation of the power of the engine may then be made, based on the piston displacement only. This justifies in some measure the various rules proposed for rating automobile engines (30 a). One of these rules is, brake hp. = $\frac{d^2 n}{2.5}$, where n is the number of four-cycle cylinders of diameter d inches, running at a piston speed of 1000 ft. per minute.

CURRENT GAS ENGINE FORMS

336. Otto Cycle Oil Engines. This class includes, among many others, the Mietz and Weiss, two-cycle, and the Daimler, Priestman, and Hornsby-Akroyd, four-cycle. In the last-named, shown in Fig. 151, kerosene oil is injected by a small pump into the vaporizer. Air is drawn into the cylinder during the suction stroke, and compressed into the vaporizer on the compression stroke, where the simultaneous presence of a critical mixture and a high temperature produces the explosion. External heat must be applied for starting. The point of ignition is determined by the amount of compression; and this may be varied by adjusting

the length of the connecting rod on the valve gear. The engine is governed by partially throttling the charge of oil, thus weakening the mixture and the force of

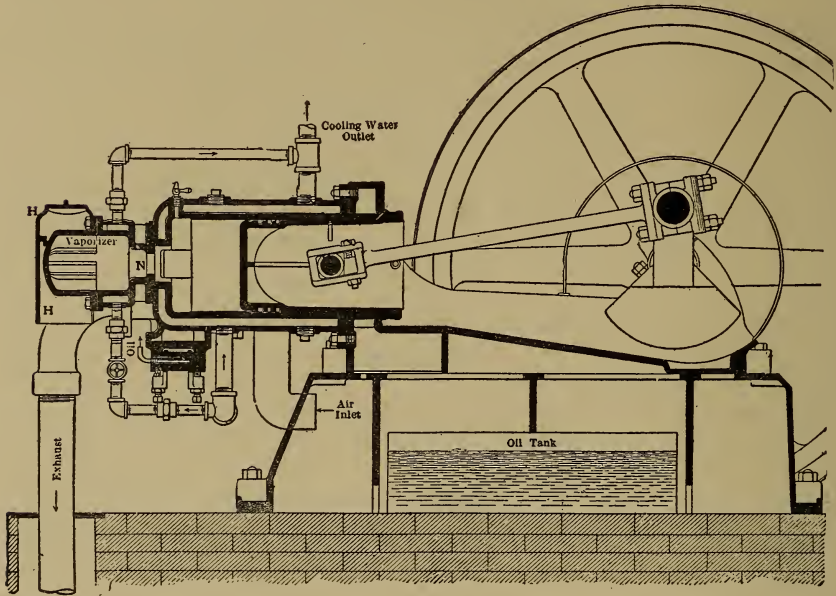

FIG. 151. Arts. 322, 336.—Kerosene Engine with Vaporizer.

(From "The Gas Engine," by Cecil P. Poole, with the permission of the Hill Publishing Company.)

the explosion. The oil consumption may be reduced to less than 1 lb. per brake hp. per hour.

In the Priestman engine, an earlier type, air under pressure sprayed the oil into a vaporizer kept hot by the exhaust gases. The method of governing was to reduce the quantity of charge without changing its proportions. A hand pump and external heat for the vaporizer were necessary in starting. An indicated thermal efficiency of 0.165 has been obtained. The Daimler (German) engine uses hot-tube ignition without a timing valve, the hot tube serving as a vaporizer. Extraordinarily high speeds are attained.

337. Modern Gas Engines : the Otto. The present-day small Otto engine is ordinarily single-cylinder and single-acting, governing on the "hit or miss" principle (Art. 343). It is used with all kinds of gas and with gasoline. Ignition is electrical, the cylinder water jacketed, the jackets cast separately from the cylinder. The Foos engine, a simple, compact form, often made portable, is similar in principle. In the Crossley-Otto, a leading British type, hot-tube ignition is used, and the large units have two horizontal opposed single-acting cylinders. In the Andrews form, tandem cylinders are used, the two pistons being connected by external side rods.

338. The Westinghouse Engine. This has recently been developed in very large units. Figure 152 shows the working side of a two-cylinder, tandem, double acting engine, representing the inlet valves on top of the cylinders.

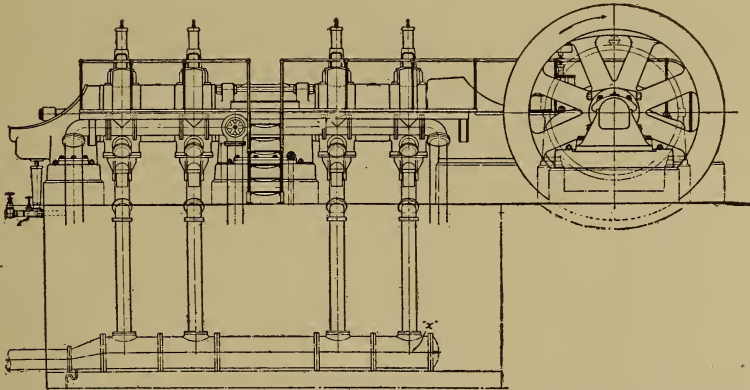

FIG. 152. Arts. 338, 350. — Westinghouse Gas Engine. Two-cylinder Tandem, Four-cycle.

Smaller engines are often built vertical, with one, two, or three single-acting cylinders. All of these engines are four-cycle, with electric ignition, governing by varying the quantity and proportions of the admitted mixture. Sections of the cylinder of the **Riverside** horizontal, tandem, double-acting engine are shown in Fig. 153. It has an extremely massive frame. The **Allis-Chalmers** engine is built in large units along similar general lines. Thirty-six of the latter engines of 4000 hp. capacity each on blast furnace gas are now (1909) being constructed. They weigh, each, about 1,500,000 lb., and run at $83\frac{1}{2}$ r. p. m. The cylinders are 44 by 54 in. Nearly all are to be direct-connected to electric generators.

339. Two-cycle Engines. In these, the explosions are twice as frequent as with the four-cycle engine, and cooling is consequently more difficult. With an equal number of cylinders, single- or double-acting, the two-cycle engine of course gives better regulation. The first important two-cycle engine was introduced by Clerk in 1880. The principle was the same as that of the engine shown in Fig. 119. The **Oechelhaueser** engine has two single-acting pistons in one cylinder, which are connected with cranks at 180° , so that they alternately approach toward and recede from each other. The engine frame is excessively long. Changes in the quantity of fuel supplied control the speed. The **Koerting** engine, a double-acting horizontal form, has two pumps, one for air and one for gas. A "scavenging" charge of air is admitted just prior to the entrance of the gas, sweeping out the burnt gases and acting as a cushion between the incoming charge and the exhaust ports. The engine is built in large units, with electrical ignition and compressed air starting gear. The speed is controlled by changing the mixture proportions.

340. Special Engines. For motor bicycles, a single air-cooled cylinder is often used, with gasoline fuel. Occasionally, two cylinders are employed. The engine

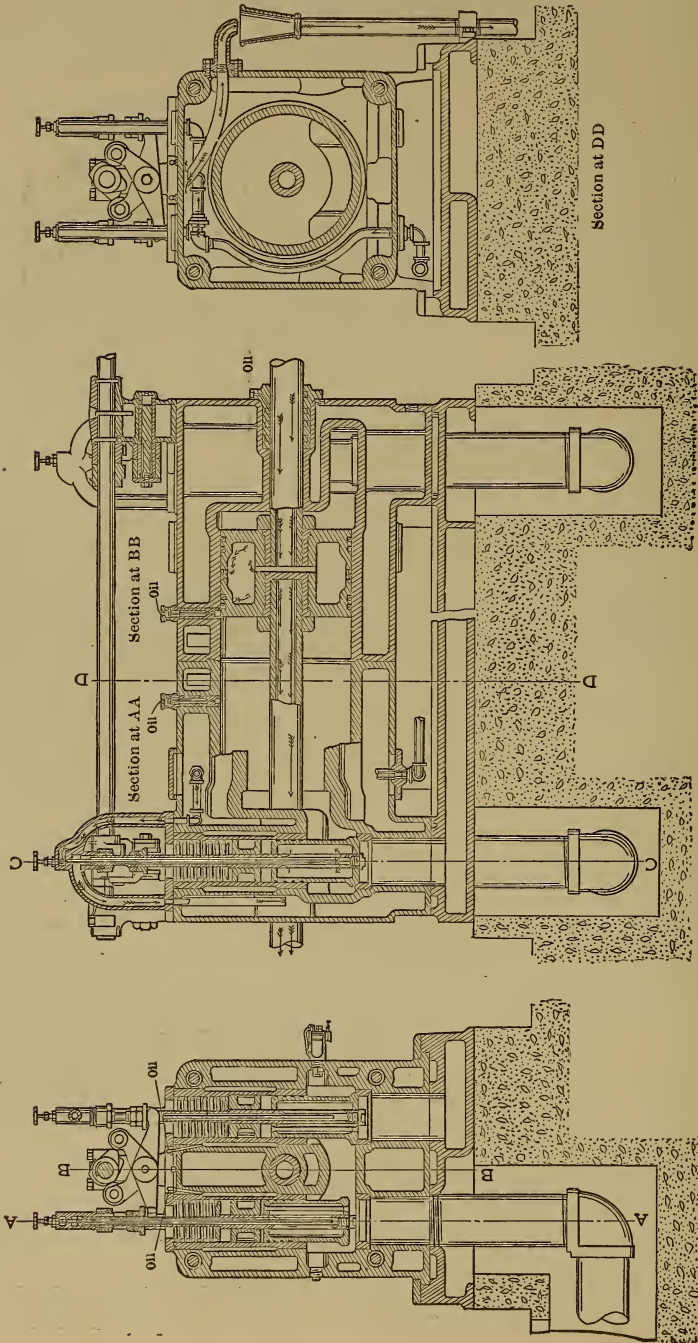

Fig. 153. Arts. 338, 350. — Tandem Double-acting Gas Engine. (Riverside Engine Company.)

is four-cycle and runs at high speed. Starting is effected by foot power, which can be employed whenever desired. Ignition is electrical and adjustable. The speed is controlled by throttling. Extended surface air-cooled cylinders have also been used on automobiles, a fan being employed to circulate the air, but the limit of size appears to be about 7 hp. per cylinder. Most automobiles have water-cooled cylinders, usually four in number, four-cycle, single-acting, running at about 1000 to 1200 r. p. m., normally. Governing is by throttling and by changing the point of ignition. The cylinders are usually vertical, the jacket water being circulated by a centrifugal pump, and being used repeatedly. Both hot-tube and electrical methods of ignition have been employed, but the former is now almost wholly obsolete. The number of cylinders varies from one to six; occasionally they are arranged horizontally, duplex, or opposed. Two-cycle engines have been introduced. The fuel in this country is usually gasoline. For launch engines, the two-cycle principle is popular, the crank case forming the pump chamber, and governing being accomplished by throttling. Kerosene or gasoline are the fuels.

341. Alcohol Engines. These are used on automobiles in France. A special carburetor is employed. The cylinder and piston arrangement is sometimes that of the Oechelhaeser engine (Art. 339). The speed is controlled by varying the point of ignition. In launch applications, the alcohol is condensed, on account of its high cost, and in some cases is not burned, but serves merely as a working fluid in a "steam" cylinder, being alternately vaporized by an externally applied gasoline flame and condensed in a surface condenser. The low value of the latent heat of vaporization (Art. 360) of alcohol permits of "getting up steam" more rapidly than is possible in an ordinary steam engine.

342. Basis of Efficiency. The performances of gas engines may be compared by the cubic feet of gas, or pounds of liquid fuel, or pounds of coal gasified in the producer, per horse power hour; but since none of these figures affords any really definite basis, on account of variations in heating value, it is usual to express the results of trials in **heat units consumed per horse power per minute**. Since one horse power equals $33,000 \div 778 = 42.42$ B. t. u. per minute, this constant divided by the heat unit consumption gives the **indicated thermal efficiency**. In making tests, the over-all efficiency of a producer plant may be ascertained by weighing the coal. When liquid fuel is used, the engine efficiency can readily be determined separately. To do this with gas involves the measurement of the gas, always a matter of some difficulty with any but small engines. The measurement of power by the indicator is also inaccurate, possibly to as great an extent as 5 per cent, which may be reduced to 2 per cent, according to Hopkinson, by employing mirror indicators. This error has resulted in the custom of expressing performance in heat units consumed per **brake horse power per hour** or per kw.-hr., where the engines are directly connected to generators. There is some question as to the proper method of considering the negative loop, *bcde*, of Fig. 136. By some, its area is deducted from the gross work area, and the difference used in computing the indicated horse power. By others, the gross work area of Fig. 136 is alone considered, and the "fluid friction" losses

producing the negative loop are then classed with engine friction as reducing the "mechanical efficiency." Various codes for testing gas engines are in use (31).

343. Typical Figures. Small oil or gasoline engines may easily show 10 per cent brake efficiency. Alcohol engines of small size consume less than 2 pt. per brake hp.-hr. at full load (32). A well-adjusted Otto engine has given an indicated thermal efficiency of 0.19 with gasoline and 0.23 with kerosene (33). Ordinary producer gas engines of average size under test conditions have repeatedly shown indicated thermal efficiencies of 25 to 29 per cent. A Cockerill engine gave 30 per cent. Hubert (34) tested at Seraing an engine showing nearly 32 per cent indicated thermal efficiency. Mathot (35) reports a test of an Ehrhardt and Lehmer double-acting, four-cycle 600 hp. engine at Heinitz which reached nearly 38 per cent. A blast furnace gas engine gave at full load 25.4 per cent. Expressed in pounds of coal, one plant with a low load factor gave a kilowatt-hour per 1.8 lb. In another case, 1.59 lb. was reached, and in another, 2.97 lb. of wood per kw.-hr. It is common to hear of guarantees of 1 lb. of coal per brake hp.-hr., or of 11,000 B. t. u. in gas. A recent test of a Crossley engine is reported to have shown the result 1.13 lb. of coal per kw.-hr. Under ordinary running conditions, 1.5 to 2.0 lb. with varying load may easily be realized. These latter figures are of course for coal burned in the producer. They represent the joint efficiency of the engine and the producer. The best results have been obtained in Germany. For the engine alone, Schröter is reported to have obtained on a Guldner engine an indicated thermal efficiency of 0.427 at full load with illuminating gas (36).

The efficiency cannot exceed that of the ideal Otto cycle. In one test of an Otto cycle engine an indicated thermal efficiency of 0.37 was obtained, while the ideal Otto efficiency was only 0.41. The engine was thus within 10 per cent of perfection for its cycle.*

The Diesel engine has given from 0.32 to 0.412 indicated thermal efficiency. Its cycle, as has been shown, permits of higher efficiency than that of Otto.

344. Plant Efficiency. Figures have been given on coal consumption. Overall efficiencies from fuel to indicated work have ranged from 0.14 upward. At the Maschinenfabrik Winterthur, a consumption of 0.7 lb. of coal (13,850 B. t. u.) per brake hp.-hr. at full load has been reported (37). This is closely paralleled by the 0.285 plant efficiency obtained on the Guldner engine mentioned in Art. 343 when operated with a suction producer on anthracite coal. At the Royal Foundry, Wurttemberg (38), 0.78 lb. of anthracite were burned per Ihp.-hr., and at the Imperial Post Office, Hamburg, 0.93 lb. of coke. In the best engines, variations of efficiency with reasonable changes of load below the normal have been greatly reduced, largely by improved methods of governing.

345. Mechanical Efficiency. The ratio of work at the brake to *net* indicated work ranges about the same for gas as for steam engines having the same arrangement of cylinders. When mechanical efficiency is understood in this sense, its

* At the present time, any reported efficiency much above 30 per cent should be regarded as needing authoritative confirmation.

value is nearly constant for a given engine at all loads, decreasing to a slight extent only as the load is reduced. In the other sense, suggested in Art. 342, *i.e.* the mechanical efficiency being the ratio of work at the brake to *gross* indicated work (no deduction being made for the negative loop area of Fig. 136), its value falls off sharply as the load decreases, on account of the increased proportion of "fluid friction." Lucke gives the following as average values for the mechanical efficiency in the latter sense:

ENGINE	MECHANICAL EFFICIENCY	
	<i>Four-cycle</i>	<i>Two-cycle</i>
Large, 500 Ihp. and over,	0.81 to 0.86	0.63 to 0.70
Medium, 25 to 500 Ihp.,	0.79 to 0.81	0.64 to 0.66
Small, 4 to 25 Ihp.,	0.74 to 0.80	0.63 to 0.70

The friction losses for a *single-acting* engine are of course relatively greater than those for an ordinary double-acting steam engine.

346. Heat Balance. The principal losses in the gas engine are due to the cooling action of the jacket water (a necessary evil in present practice) and to the heat carried away in the exhaust. The arithmetical means of nine trials collated by the writer give the following percentages representing the disposition of the total heat supplied: to the jacket, 40.52; to the exhaust, 33.15; work, 21.87; unaccounted for, 6.23. Hutton (40) tabulates a large number of trials, from which similar arithmetical averages are derived as follows: to the jacket, 37.96; to the exhaust, 29.84; work, 22.24; unaccounted for, 8.6. In general, the larger engines show a greater proportion of heat converted to work, an increased loss to the exhaust and a decreased loss to the jacket. In working up a "heat balance," the loss to the exhaust is measured by a calorimeter, which cools the gases below 100° F. The heat charged to the engine should therefore be based on the "high" heat value of the fuel (Arts. 561, 561*a*). The "work" item in the above heat balance is indicated work, not brake work.

Unlike the jacket water heat (Art. 352), the heat carried off in the exhaust gases is at fairly high temperature. There would be a decided gain if this heat could be even partly utilized. Suppose the engine to have consumed, per hp., 10,000 B. t. u. per hour, of which 30 per cent, or 3000 B. t. u., passes off at the exhaust. At 80 per cent efficiency of utilization, 2400 B. t. u. could then be recovered. In forming steam at 100 lb. absolute pressure from feed water at 212° F., 1006.3 B. t. u. are needed per pound of steam. Each horse power of the gas engine would then give as a waste gas by-product $2400 \div 1006.3 = 2.39$ lb. of steam. Or if the steam plant had an efficiency of 10 per cent, 240 B. t. u. could be obtained in work from the steam engine for each horse power of the gas engine. This is $240 \div 2545 = 9\frac{1}{2}$ per cent of the work given by the gas engine. A much higher gain would be possible if the steam generated by the exhaust gases were used for heating rather than for power production.

347. Entropy Diagram. When the PV diagram is given, points may be transferred to the entropy plane by the formula $n_b - n_a = k \log_e \frac{V_b}{V_a} + l \log_e \frac{P_b}{P_a}$ (Art. 169). The state a may be taken at 32° F. and atmospheric pressure; then the entropy at any other state b depends simply upon V_b and P_b . To find V_a , we must know the equation of the gas. According to Richmond, (41) the mean value of k may be taken at 0.246 on the compression curve and at 0.26 on the expansion curve, while the mean values of l corresponding are 0.176 and 0.189. The values of R are then $778(0.246 - 0.176) = 54.46$ and $778(0.260 - 0.189) = 55.24$. The characteristic equations are, then, $PV = 54.46 T$ along the compression curve; and $PV = 55.24 T$ along the expansion curve. The formula gives changes of entropy *per pound* of substance. The indicator diagram does not ordinarily depict the behavior of one pound; but if the weight of substance used per cycle be known, the volumes taken from the PV diagram may be converted to specific volumes for substitution in the formula.

It is sometimes desirable to study the TV relations throughout the cycle. In Fig. 154, let $ABCD$ be the PV diagram. Let EF be any line of constant volume intersecting this diagram at G, H . By Charles' law, $T_G : T_H :: P_G : P_H$. The

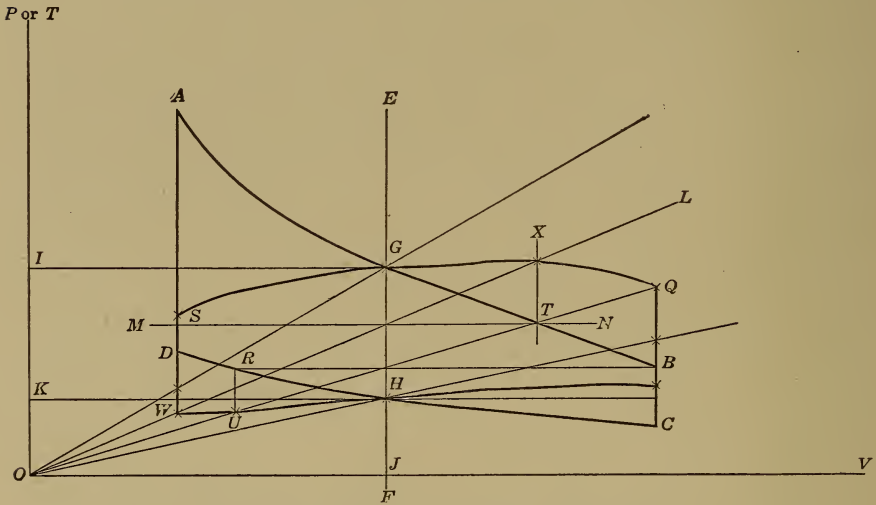

FIG. 154. Art. 347. — Gas Engine TV Diagram.

ordinates JG, JH may therefore serve to represent temperatures as well as pressures, to some scale as yet undetermined. If the ordinate JG represent *temperature*, then the line OG is a line of *constant pressure*. Let the pressure along this line on a TV diagram be the same as that along IG on a PV diagram. Then (again by Charles' law) the line OH is a line of constant pressure on the TV plane, corresponding to the line KH on the PV plane. Similarly, OL corresponds to MN and OQ to RB . Project the points S, T, R, B , where MN and RB intersect the PV diagram, until they intersect OL, OQ . Then points U, Q, W, X are

points on the corresponding TV diagram. The scale of T is determined from the characteristic equation; the value of R may be taken at a mean between the two given. A transfer may now be made to the NT plane by the aid of the equation $n_b - n_a = l \log_e \frac{T_b}{T_a} + (k - l) \log_e \frac{V_b}{V_a}$ (Art. 169), in which $T_a = 491.6$,

$$V_a = \frac{54.46 \times 491.6}{2116.8} = 12.64.$$

Figure 155, from Reeve (42), is from a similar four-cycle engine. The enormous area $BACD$ represents heat lost to the water jacket. The inner dead center of the engine is at x ; thereafter, for a short period, heat is evidently abstracted from the fluid, being afterward restored, just as in the case of a steam engine (Art. 431), because during expansion the temperature of the gases falls below that of the cylinder walls. This agrees with the usual notion that most of the heat is discharged to the jacket early in the expansion stroke. It would probably be a fair assumption to consider this loss to occur during *ignition*, as far as its effect on the diagram is concerned. Reeve gives several instances in which the expansive path resembles $xBzD$; other investigators find a *constant loss of heat during expansion*. Figure 156 gives the PV and NT diagrams for a Hornsby-Akroyd engine; the expansion line bc here actually rises above the *isothermal*, indicative of excessive after burning.

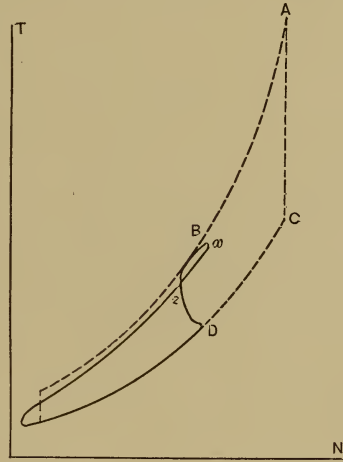

FIG. 155. Art. 347. — Gas Engine Entropy Diagram.

348. Methods of Governing. The power exerted by an Otto cycle engine may be varied in accordance with the external load by various methods; in order that efficiency may be maintained, the governing should not lower the ratio of pressures during compression. To ensure

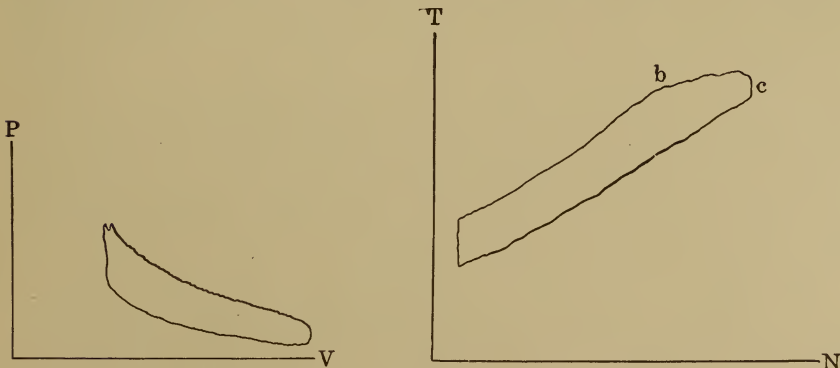

FIG. 156. Art. 347. — Diagrams for Hornsby-Akroyd Engine.

this, variation of the clearance, by mechanical means or water pockets and outside compression have been proposed, but no practicably efficient means have yet been developed. The speed of an engine may be changed by varying the point of ignition, a most wasteful method, because the reduction in power thus effected is unaccompanied by any change whatever in fuel consumption. Equally wasteful is the use of excessively small ports for inlet or exhaust, causing an increased negative loop area and a consequent reduction in power when the speed tends to increase. In engines where the combustion is gradual, as in the Brayton or Diesel, the point of cut-off of the charge may be changed, giving the same sort of control as in a steam engine.

Three methods of governing Otto cycle engines are in more or less common use. In the "*hit-or-miss*" plan, the engine omits drawing in its charge as the external load decreases. One or more idle strokes ensue. *No loss of economy results* (at least from a theoretical standpoint), but the speed of the engine is apt to vary on account of the increased irregularity of the already occasional impulses. Governing *by changing the proportions of the mixture* (the total amount being kept constant) should apparently not affect the compression; actually, however, the compression must be

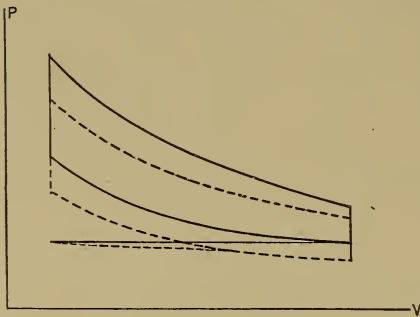

FIG. 157. Art. 348. — Effect of Throttling.

fixed at a sufficiently low point to avoid danger of pre-ignition to the strongest probable mixture, and thus at other proportions the degree of compression will be less than that of highest efficiency. A change in the *quantity* of the mixture, without change in its proportions, by throttling the suction or by entirely closing the inlet valve toward the end of the suction stroke, results in a decided change

of compression pressure, the superimposed cards being similar to those shown in Fig. 157. In theory, at least, the *range* of compression pressures would not be affected; but the variation in proportion of clearance gas present requires injurious limitations of final compression pressure, just as when governing is effected by variations in mixture strength. Besides, the rapidity of flame propagation is strongly influenced by variations in the pressure at the end of compression.

349. Defects of Gas Engine Governing. The hit-or-miss system may be regarded as entirely inapplicable to large engines. The other practicable methods sacrifice the efficiency. Further than this, the

governing influence is exerted during the suction stroke, one full revolution (in four-cycle engines) previous to the working stroke, which should be made equal in effort to the external load. If the load changes during the intervening revolution, the control will be inadequate. Gas engines tend therefore to irregularity in speed and low efficiency under variable or light loads. The first disadvantage is overcome by increasing the number of cylinders, the weight of the fly wheel, etc., all of which entails additional cost. The second disadvantage has not yet been overcome. In most large power plant engines, both the quantity and strength of the mixture are varied by the governor.

350. Construction Details. The irregular impulses characteristic of the gas engine and the high initial pressures attained require excessively heavy and strong frames. For anything like good regulation, the fly wheels must also be exceptionally heavy. For small engines, the bed casting is usually a single heavy piece. The type of frame usually employed on large engines is illustrated in Fig. 152. It is in contact with the foundation for its entire length, and in many cases is tied together by rods at the top extending from cylinder to cylinder.

Each working end of the cylinder of a four-cycle engine must have two valves, —one for admission and one for exhaust. In many cases, three valves are used, the air and gas being admitted separately. The valves are poppet, of the plain disk or mushroom type, with beveled seats; in large engines, they are sometimes of the double-beat type, shown in Fig. 153. Sliding valves cannot be employed at the high temperature of the gas cylinder.* Exhaust opening must always be under positive control; the inlet valves may be automatic if the speed is low, but are generally mechanically operated on large engines. All should be finally seated by spring action, so as to avoid shocks. In horizontal four-cycle engines, a cam shaft is driven from an eccentric at half the speed of the engine. Cams or eccentrics on this shaft operate each of the controlling valves by means of adjustable oscillating levers, a supplementary spring being employed to accelerate the closing of the valves. In order that air or gas may pass at constant speed through the ports, the cam curve must be carefully proportioned with reference to the variation in conditions in the cylinder (43). Hutton (44) advises proportioning of ports such that the mean velocity may not exceed 60 ft. per second for automatic inlet valves, 90 ft. for mechanically operated valves, and 75 ft. for exhaust valves, on small engines.

351. Starting Gear. No gas engine is self-starting. Small engines are often started by turning the fly wheel by hand, or by the aid of a bar or gearing. An auxiliary hand air pump may also be employed to begin the movement. A small electric motor is sometimes used to drive a gear-faced fly wheel with which the motor pinion meshes. In all cases, the engine starts against its friction load only, and it is usual to provide a method for keeping the exhaust valve open during part of the compression stroke so as to decrease the resistance. In multiple-cylinder engines, as in automobiles, the ignition is checked just prior to stopping. A compressed but unexploded charge will then often be available for restarting. In the

* The sleeve valve, analogous to the piston valve commonly used on locomotives, has been successfully developed for automobile work

Clerk engine, a supply of unexploded mixture was taken during compression from the cylinder to a strong storage tank, from which it could be subsequently drawn. Gasoline railway motor cars are often started by means of a smokeless powder cartridge exploded in the cylinder. Modern large engines are started by compressed air, furnished by a direct-driven or independent pump, and stored in small tanks. Recent automobile practice has developed two new starting methods: (a) By acetylene generated from calcium carbide and water under pressure, and (b) by an electric motor, operated from a storage battery which is charged while the engine is running. The same battery lights the car.

352. Jackets. The use of water-spray injection during expansion has been abandoned, and air cooling is practicable only in small sizes (say, for diameters less than 5-inch). The cylinder, piston, piston rod, and valves must usually be thoroughly water-jacketed.* Positive circulation must be provided, and the water cannot be used over again unless artificially cooled. At a heat consumption of 200 B. t. u. per minute per Ihp., with a 40 per cent loss to the jacket, the theoretical consumption of water heated from 80 to 160° F. is exactly 1 lb. per Ihp. per minute. This is greater than the water consumption of a non-condensing steam plant, but much less than that of a condensing plant. The discharge water from large engines is usually kept below 130° F. In smaller units, it may leave the jackets at as high a temperature as 160° F. The usual rise of temperature of water while passing through the jackets is from 50 to 100° F. The circulation may be produced either by gravity or by pumping.

353. Possibilities of Gas Power. The gas engine, at a comparatively early stage in its development, has surpassed the best steam engines in thermal efficiency. Mechanically, it is less perfect than the latter; and commercially it is regarded as handicapped by the greater reliability, more general field of application, and much lower cost (excepting, possibly, in the largest sizes †) of the steam engine. The use of producer gas for power eliminates the coal smoke nuisance; the stand-by losses of producers are low; and gas may be stored, in small quantities at least. The small gas engine is quite economical and may be kept so. The small steam engine is usually wasteful. The Otto cycle engine regulates badly, a disadvantage which can be overcome at excessive cost; it is not self-starting; the cylinder must be cooled. Even if the mechanical necessity for jacketing could be overcome, the same loss would be experienced, the heat being then carried off in the exhaust. The ratio of expansion is too low, causing excessive waste of heat at the exhaust, which, however, it may prove possible to reclaim. The heat in the jacket water is large in quantity and low in temperature, so that the problem of utilization is confronted with the second law of thermodynamics. Methods of reversing have not yet been worked out, and no important marine applications of gas power have been made, although small producer plants have been installed for ferryboat service with clutch reversal, and compressed and

* The piston need not be cooled in single-acting four-cycle engines.

† Piston speeds of large gas engines may exceed those of steam engines. Unless special care is exercised in the design of ports, the efficiency will fall off rapidly with increasing speed. Gas engines have been built in units up to 8000 hp. :-2000 hp. from each of the four twin-tandem double-acting cylinders.

stored gas has been used for driving river steamers in France, England, and Germany.

The proposed combinations of steam and gas plants, the gas plant to take the uniform load and the steam units to care for fluctuations, really beg the whole question of comparative desirability. The bad "characteristic" curve—low efficiency at light loads and absence of *bona fide* overload capacity—will always bar the gas engine from some services, even where the storage battery is used as an auxiliary. Many manufacturing plants must have steam in any case for process work. In such, it will be difficult for the gas engine to gain a foothold. For the utilization of blast furnace waste, even aside from any question of commercial power distribution, the gas engine has become of prime economic importance.

[A topical list of research problems in gas power engineering, the solution of which is to be desired, is contained in the *Report of the Gas Power Research Committee of the American Society of Mechanical Engineers (1910).*]

[See the *Résumé of Producer Gas Investigations*, by Fernald and Smith, Bulletin No. 13 of the United States Bureau of Mines, 1911.]

(1) Hutton, *The Gas Engine*, 1908, 545; Clerk, *Theory of the Gas Engine*, 1903, 75. (2) Hutton, *The Gas Engine*, 1908, 158. (3) Clerk, *The Gas Engine*, 1890, 119-121. (4) *Ibid.*, 129. (5) *Ibid.*, 133. (6) *Ibid.*, 137. (7) *Ibid.*, 198. (8) *Engineering News*, October 14, 1906, 357. (9) Lucke and Woodward, *Tests of Alcohol Fuel*, 1907. (10) Junge, *Power*, December, 1907. (10 a) For a fuller exposition of the limits of producer efficiency with either steam or waste gas as a diluent, see the author's paper, *Trans. Am. Inst. Chem. Engrs.*, Vol. II. (11) *Trans. A. S. M. E.*, XXVIII, 6, 1052. (12) A test efficiency of 0.657 was obtained by Parker, Holmes, and Campbell: *United States Geological Survey*, Professional Paper No. 48. (13) Ewing, *The Steam Engine*, 1906, 418. (14) Clerk, *The Theory of the Gas Engine*, 1903. (15) *Theorie und Construction eines rationellen Warmemotors*. (16) Zeuner, *Technical Thermodynamics* (Klein), 1907, I, 439. (17) *Trans. A. S. M. E.*, XXI, 275. (18) *Ibid.*, 286. (19) *Op. cit.*, XXIV, 171. (20) *Op. cit.*, XXI, 276. (21) *Gas Engine Design*, 1897, 33. (22) *Op. cit.*, p. 34 *et seq.* (23) See Lucke, *Trans. A. S. M. E.*, XXX, 4, 418. (24) *The Gas Engine*, 1890, p. 95 *et seq.* (25) A. L. Westcott, *Some Gas Engine Calculations based on Fuel and Exhaust Gases*; *Power*, April 13, 1909, p. 693. (26) Hutton, *The Gas Engine*, 1908, pp. 507, 522. (27) *The Gas Engine*, 1908. (28) Clerk, *op. cit.*, p. 216. (29) *Op. cit.*, p. 291. (30) *Op. cit.*, p. 38. The corresponding usual mean effective pressures are given on p. 36. (30 a) See the author's papers, *Commercial Ratings for Internal Combustion Engines*, in *Machinery*, April, 1910, and *Design Constants for Small Gasolene Engines, with Special Reference to the Automobile*, *Journal A. S. M. E.*, September, 1911. (31) *Zeits. Ver. Deutsch. Ing.*, November 24, 1906; *Power*, February, 1907. (32) *The Electrical World*, December 7, 1907, p. 1132. (33) *Trans. A. S. M. E.*, XXIV, 1065. (34) *Bul. Soc. de l'Industrie Mineral*, Ser. III, XIV, 1461. (35) *Trans. A. S. M. E.*, XXVIII, 6, 1041. (36) Quoted by Mathot, *supra*. (37) Also from Mathot. (38) Mathot, *supra*. (40) *Op. cit.*, pp. 342-343. (41) *Trans. A. S. M. E.*, XIX, 491. (42) *Ibid.*, XXIV, 171. (43) Lucke, *Gas Engine Design*, 1905. (44) *Op. cit.*, 483.

SYNOPSIS OF CHAPTER XI

The Producer

The importance of the gas engine is largely due to the *producer process* for making cheap gas.

In the gas engine, *combustion occurs in the cylinder*, and the highest temperature attained by the substance determines the cyclic efficiency.

Fuels are natural gas, carbureted and uncarbureted water gas, coal gas, coke oven gas, producer gas, blast furnace gas; gasoline, kerosene, fuel oil, distillate, alcohol, coal tars.

The *gas producer* is a lined cylindrical shell in which the fixed carbon is converted into carbon monoxide, while the hydrocarbons are distilled off, the necessary heat being supplied by the fixed carbon burning to CO.

The maximum theoretical efficiency of the producer making power gas is *less than that of the steam boiler*. Either *steam* or *exhaust gas* from the engine must be introduced to attain maximum efficiency. The reactions are complicated and partly reversible.

The mean composition of producer gas, by volume, is CO, 19.2; CO₂, 9.5; H, 12.4; CH₄, C₂H₄, 3.1; N, 55.8.

The "*figure of merit*" is the heating value of the gas per pound of carbon contained.

Gas Engine Cycles

The Otto cycle is bounded by *two adiabatics and two lines of constant volume*; the engine may operate in either the *four-stroke cycle* or the *two-stroke cycle*.

In the two-stroke cycle, the inlet and exhaust ports are *both open at once*.

In the *Otto cycle*, $\frac{P_b}{P_c} = \frac{P_f}{P_d}$ and $\frac{T_b}{T_e} = \frac{T_f}{T_a}$.

Efficiency = $\frac{T_e - T_d}{T_e} = 1 - \left(\frac{P_d}{P_e}\right)^{\frac{\gamma-1}{\gamma}} = \frac{T_b - T_f}{T_b} = 1 - \left(\frac{P_f}{P_b}\right)^{\frac{\gamma-1}{\gamma}}$; it depends *solely on the extent of compression*.

The Sargent and Frith cycles.

Efficiency of Atkinson engine (isothermal rejection of heat) = $1 - \frac{\gamma}{T_b - T_e} \log_e \frac{T_b}{T_e}$;
higher than that of the Otto cycle.

Lenoir cycle: constant pressure rejection of heat; efficiency = $1 - \frac{T_g - T_h}{T_f - T_d} - \gamma \frac{T_h - T_d}{T_f - T_d}$.

Brayton cycle: combustion at constant pressure; efficiency = $1 - \frac{T_g - T_h}{\gamma(T_b - T_n)} - \frac{T_h - T_d}{T_b - T_n}$;

or, with complete expansion, $\frac{T_n - T_d}{T_n}$.

A special comparison shows the *Clerk Otto engine* to give a much *higher efficiency* than the Brayton or Lenoir engine, but that the Brayton engine gives slightly the largest work area.

The *Clerk Otto* (complete pressure) cycle gives an *efficiency* of $1 - \frac{T_f - T_g}{T_e - T_c} - \gamma \frac{T_g - T_b}{T_e - T_c}$,

intermediate between that of the ordinary Otto and the Atkinson.

The Diesel cycle: isothermal combustion; efficiency = $1 - \frac{kT_a \left[\left(\frac{V_b}{V_a} \right)^{\gamma-1} - 1 \right]}{yRT_a \log_e \frac{V_b}{V_a}}$; increases as ratio of expansion decreases.

The Diesel cycle: constant pressure combustion.

The Humphrey internal combustion pump.

Modifications in Practice

The PV diagram of an actual Otto cycle engine is influenced by

- (a) proportions of the mixture, which must not be too weak or too strong, and must be controllable;
- (b) maximum allowable temperature after compression to avoid pre-ignition; the range of compression, which determines the efficiency, depends upon this as well as upon the pre-compression pressure and temperature;
- (c) the rise of pressure and temperature during combustion; always less than those theoretically computed, on account of (1) divergences from Charles' law, (2) the variable specific heats of gases, (3) slow combustion, (4) dissociation;
- (d) the shape of the expansion curve, usually above the adiabatic, on account of after burning, in spite of loss of heat to the cylinder wall;
- (e) the forms of the suction and exhaust lines, which may be affected by badly proportioned ports and passages and by improper valve action.

Dissociation prevents the combustion reaction of more than a certain proportion of the elementary gases at each temperature within the critical limits.

The point of ignition must somewhat precede the end of the stroke, particularly with weak mixtures.

Methods of ignition are by hot tube, jump spark, and make and break.

Cylinder clearance ranges from 8.7 to 56 per cent. It is determined by the compression pressure range.

Scavenging is the expulsion of the burnt gases in the clearance space prior to the suction stroke.

The diagram factor is the ratio of the area of the indicator diagram to that of the ideal cycle.

Analysis with specific heats variable.

$$\text{Mean effective pressure} = \frac{Q \left[1 - \left(\frac{P_d}{P_e} \right)^{\frac{\gamma-1}{\gamma}} \right]}{V_a - V_e}$$

Gas Engine Design

In designing an engine for a given power, the gas composition, rotative speed and piston speed are assumed. The probable efficiency may be estimated in advance. Overload capacity must be secured by assuming a higher capacity than that normally needed; the engine will do no more work than that for which it is designed.

Current Forms

Otto cycle oil engines include the Mietz and Weiss, two-cycle, and the Daimler, Priestman, and Hornsby-Akroyd, four-cycle.

Modern forms of the *Otto gas engine* include the Otto, Foos, Crossley-Otto, and Andrews.

The Westinghouse, Riverside, and Allis-Chalmers engines are built in the *largest sizes*.

Two-cycle gas engines include the Oechelhaeuser and Koerting.

Special engines are built for motor bicycles, automobiles, and launches, and for burning alcohol.

The basis of efficiency is the *heat unit consumption per horse power per minute*.

The *mechanical efficiency* may be computed from either *gross* or *net* indicated work.

Recorded efficiencies of gas engines range up to *42.7 per cent*; *plant efficiencies* to *0.7 lb. coal per brake hp.-hr.*

The mechanical efficiency increases with the size of the engine, and is greater with the four-stroke cycle.

About *33 per cent* of the heat supplied is carried off by the *jacket water*, and about *33 per cent* by the *exhaust gases*, in ordinary practice.

The entropy diagram may be constructed by transfer from the *PV* or *TV* diagrams.

Governing is effected

- | | | |
|--|--|------------------|
| (a) by the <i>hit-or-miss method</i> ; | economical, but unsatisfactory for speed regulation, | } both wasteful. |
| (b) by <i>throttling</i> , | | |
| (c) by <i>changing mixture proportions</i> , | | |

In all cases, the governing effort is exerted too early in the cycle.

Gas engines must have *heavy frames and fly wheels*; exhaust valves (and inlet valves at high speed) must be *mechanically operated* by carefully designed *cams*; provision must be made for *starting*; cylinders and other exposed parts are *jacketed*. About 1 lb. of jacket water is required per 1hp.-minute.

Gas engine *advantages*: high thermal efficiency; elimination of coal smoke nuisance; stand-by losses are low; gas may be stored; economical in small units; desirable for utilizing blast furnace gas.

Disadvantages: mechanically still evolving; of unproven reliability; less general field of application; generally higher first cost; poor regulation; not self-starting; cylinder must be cooled; low ratio of expansion; non-reversible; no overload capacity; no available by-product heat for process work in manufacturing plants.

PROBLEMS

1. Compute the volume of air ideally necessary for the complete combustion of 1 cu. ft. of gasoline vapor, C_6H_{14} .

2. Find the maximum theoretical efficiency, using pure air only, of a power gas producer fed with a fuel consisting of 70 per cent of fixed carbon and 30 per cent of volatile hydrocarbons.

3. In Problem 2, what is the theoretical efficiency if 20 per cent of the oxygen necessary for gasifying the fixed carbon is furnished by steam?

4. In Problem 3, if the hydrocarbons (assumed to pass off unchanged) are half pure hydrogen and half marsh gas, compute the producer gas composition by volume,

using specific volumes as follows: nitrogen, 12.75; hydrogen, 178.83; carbon monoxide, 12.75; marsh gas, 22.3.

5. A producer gasifying pure carbon is supplied with the theoretically necessary amount of oxygen from the atmosphere and from the gas engine exhaust. The latter consists of 28.4 per cent of CO_2 and 71.6 per cent of N, by weight, and is admitted to the extent of 1 lb. per pound of pure carbon gasified. Find the rise in temperature, the composition of the produced gas, and the efficiency of the process. The heat of decomposition of CO_2 to CO may be taken at 10,050 B. t. u. per pound of carbon.

6. Find the figures of merit in Problems 4 and 5. (Take the heating value of H at 53,400; of CH_4 , at 22,500.)

7. In Fig. 134, let $\frac{V_a}{V_e} = 4$, $P_a = 30$ (lbs. per sq. in.), $P_g = P_{g_0} = P_a + 10$, $T_b = 3000^\circ$, $T_d = 1000^\circ$ (absolute). Find the efficiency and area of each of the ten cycles, for 1 lb. of air, without using efficiency formulas.

8. In Problem 7, show graphically by the NT diagram that the Carnot cycle is the most efficient.

9. What is the maximum theoretical efficiency of an Otto four-cycle engine in which the fuel used is producer gas? (See Art. 312.)

10. What maximum temperature should theoretically be attained in an Otto engine using gasoline, with a temperature after compression of 780°F .? (The heat liberated by the gasoline, available for increasing the temperature, may be taken at 21,000 B. t. u. per pound.)

11. Find the mean effective pressure and the work done in an Otto cycle between volume limits of 0.5 and 2.0 cu. ft. and pressure limits of 14.7 and 200 lb. per square inch absolute.

12. An Otto engine is supplied with pure CO, with pure air in just the theoretical amount for perfect combustion. Assume that the dissociation effect is indicated by the formula $*(1.00 - a)(6000 - T) = 300$, in which a is the proportion of gas that will combine at the temperature $T^\circ \text{F}$. If the temperature after compression is 800°F ., what is the maximum temperature attained during combustion, and what proportion of the gas will burn during *expansion* and *exhaust*, if the combustion line is one of constant volume? The value of l for CO is 0.1758.

13. An Otto engine has a stroke of 24 in., a connecting rod 60 in. long, and a piston speed of 400 ft. per minute. The clearance is 20 per cent of the piston displacement, and the volume of the gas, on account of the speed of the piston as compared with that of the flame, is doubled during ignition. Plot its path on the PV diagram and plot the modified path when the piston speed is increased to 800 ft. per minute, assuming the flame to travel at uniform speed and the pressure to increase directly as the spread of the flame. The pressure range during ignition is from 100 to 200 lb.

14. The engine in Problem 11 is four-cycle, two-cylinder, double-acting, and makes 100 r. p. m. with a diagram factor of 0.40. Find its capacity.

15. Starting at $P_a = 14.7$, $V_a = 43.45$, $T_a = 32^\circ \text{F}$. (Fig. 122), plot (a) the ideal Otto cycle for 1 lb. of CO with the necessary air, and (b) the probable actual cycle

* This is assumed merely for illustrative purposes. It has no foundation and is irrational at limiting values.

modified as described in Arts. 309–328, and find the diagram factor. Clearance is 25 per cent of the piston displacement in both cases.

16. Find the cylinder dimensions in Art. 332 if the gas composition be as given in Art. 285. (Take the average heating value of CH_4 and C_2H_4 at 22,500 B. t. u. per pound, and assume that the gas contains the same amount of each of these constituents.)

17. Find the clearance, cylinder dimensions, and probable efficiency in Art. 332 if the engine is *two-cycle*.

18. Find the size of cylinders of a four-cylinder, four-cycle, single-acting gasoline engine to develop 30 bhp. at 1200 r. p. m., the cylinder diameter being equal to the stroke. Estimate its thermal efficiency, the theoretically necessary quantity of air being supplied.

19. An automobile consumes 1 gal. of gasoline per 9 miles run at 50 miles per hour, the horse power developed being 25. Find the heat unit consumption per Ihp. per minute and the thermal efficiency; assuming gasoline to weigh 7 lb. per gallon.

20. A two-cycle engine gives an indicator diagram in which the positive work area is 1000 ft.-lb., the negative work area 90 ft.-lb. The work at the brake is 700 ft.-lb. Give two values for the mechanical efficiency.

21. The engine in Problem 17 discharges 30 per cent of the heat it receives to the jacket. Find the water consumption in pounds per minute, if its initial temperature is 72°F .

22. In Art. 344, what was the producer efficiency in the case of the Guldner en-

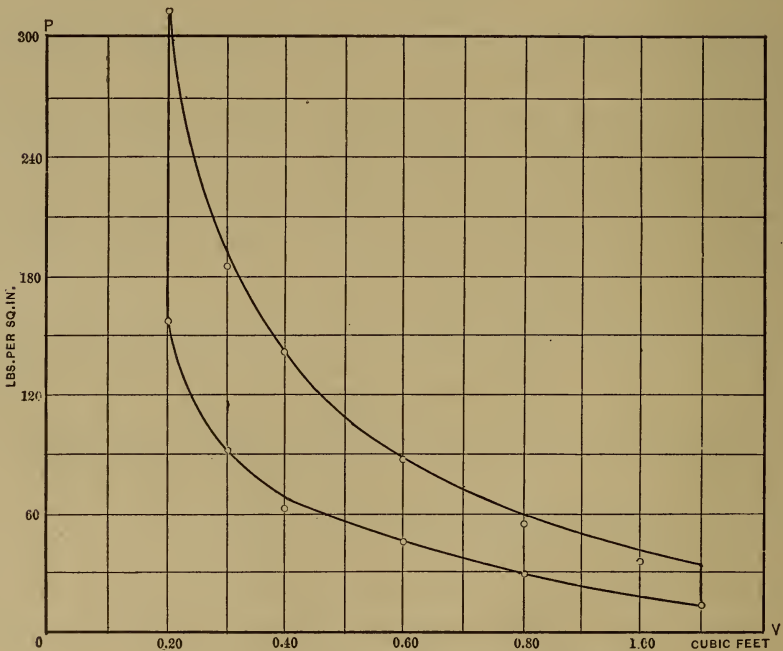

FIG. 158. Prob. 23.—Indicator Diagram for Transfer.

gine, assuming its mechanical efficiency to have been 0.85? If the coal contained 13,800 B. t. u. per pound, what was the coal consumption per brake hp.-hr.?

23. Given the indicator diagram of Fig. 158, plot accurately the TV diagram, the engine using 0.0462 lb. of substance per cycle. Draw the compressive path on the NT diagram by both of the methods of Art. 347.

24. The engine in Problem 17 governs by throttling its charge. To what percentage of the piston displacement should the clearance be decreased in order that the pressure after compression may be unchanged when the pre-compression pressure drops to 10 lb. absolute? What would be the object of such a change in clearance?

25. In the Diesel engine, Problem 7, by what percentages will the efficiency and capacity be affected, theoretically, if the supply of fuel, is cut off 50 per cent earlier in the stroke? (*i.e.*, cut-off occurs when the volume is $\frac{V_b - V_a}{2} + V_a$, Fig. 134.)

26. Under the conditions of Art. 335, develop a relation between piston displacement in cubic inches per minute, and Ihp., for four cylinder four-cycle single acting gasolene engines. Also find the relation between cylinder volume and Ihp. if engines run at 1500 r. p. m., and the relation between cylinder diameter and Ihp. if bore = stroke, at 1500 r. p. m.

27. In an Otto engine, the range of pressures during compression is from 13 to 130 lb., the compression curve $pv^{1.3} = c$. Find the percentage of clearance.

28. The clearance space of a 7 by 12 in. Otto engine is found to hold 6 lb. of water at 70° F. Find the ideal efficiency of the engine. (See Art. 295.)

29. An engine uses 220 cu. ft. of gas, containing 800 B. t. u. per cubic foot, in 39 minutes, while developing 12.8 hp. Find its thermal efficiency.

30. In the formula, brake hp. = $\frac{d^2n}{2.5}$ (Art. 335), if the mechanical efficiency is 0.80, what mean effective pressure is assumed in the cylinder?

31. A six-cylinder four-cycle engine, single-acting, with cylinders 16 by 24 in., develops 500 hp. at 200 r. p. m. What is the mean effective pressure?

32. An engine uses 1.62 lb. of gasolene (21000 B. t. u. per pound) per Bhp.-hr. What is its efficiency from fuel to shaft? If it is a 2-cycle engine with a pressure of 60 lb. gage at the end of compression, estimate the ideal efficiency.

CHAPTER XII

THEORY OF VAPORS

354. Boiling of Water. If we apply heat to a vessel of water open to the atmosphere, an increase of temperature and a slight increase of volume may be observed. The increase of temperature is a gain of **internal energy**; the slight increase of volume against the constant resisting pressure of the atmosphere represents the performance of **external work**, the amount of which may be readily computed. After this operation has continued for some time, a temperature of 212° F. is attained, and **steam** begins to form. The water now gradually disappears. The steam occupies a much larger space than the water from which it was formed; a considerable amount of *external work* is done in thus augmenting the volume against atmospheric pressure; and the **common temperature of the steam and the water remains constant at 212° F. during evaporation.**

355. Evaporation under Pressure. The same operation may be performed in a closed vessel, in which a pressure either greater or less than that of the atmosphere may be maintained. The water will now boil at some other temperature than 212° F.; at a *lower temperature*, if the pressure is *less than atmospheric*, and at a *higher temperature*, if *greater*. The latter is the condition in an ordinary steam boiler. If the water be heated until it is all boiled into steam, it will then be possible to indefinitely increase the temperature of the steam, a result **not possible as long as any liquid is present**. The temperature at which boiling occurs may range from 32° F. for a pressure of 0.089 lb. per square inch, absolute, to 428° F. for a pressure of 336 lb.; but for each pressure there is a **fixed temperature of ebullition.***

* A striking illustration is in the case of air, which has a boiling point of -314° F. at atmospheric pressure. As we see "liquid air," it is always boiling. If we attempted to confine it, the pressure which it would exert would be that corresponding to the room temperature, several thousand pounds per square inch.

Hydrogen has an atmospheric boiling point of -423° F.

356. Saturated Vapor. Any vapor in contact with its liquid and in thermal equilibrium (*i.e.*, not constrained to receive or reject heat) is called a **saturated vapor**. It is at the minimum temperature (that of the liquid) which is possible **at the existing pressure**. Its density is consequently the maximum possible at that pressure. Should it be deprived of heat, it cannot fall in temperature until after it has been first completely liquefied. If its pressure is fixed, its temperature and density are also fixed. Saturated vapor is then briefly definable as vapor at the minimum temperature or maximum density possible under the imposed pressure.

357. Superheated Vapor. A saturated vapor subjected to additional heat at constant pressure, if in the presence of its liquid, cannot rise in temperature; the only result is that more of the liquid is evaporated. When all of the liquid has been evaporated, or if the vapor is conducted to a separate vessel where it may be heated while **not in contact with the liquid**, its temperature may be made to rise, and it becomes a **superheated vapor**. It may be now regarded as an imperfect gas; as its temperature increases, it constantly becomes more nearly perfect. Its temperature is always greater, and its density less, than those properties of saturated vapor at the same pressure; either temperature or density may, however, be varied at will, excluding this limit, the pressure remaining constant. At constant pressure, the temperature of steam separated from water increases as heat is supplied.

The characteristic equation, $PV = RT$, of a perfect gas is inapplicable to steam. (See Art. 390.) The relation of pressure, volume, and temperature is given by various empirical formulas, including those of Joule (1), Rankine (2), Hirn (3), Racknel (4), Clausius (5), Zeuner (6), and Knoblauch Linde and Jakob (7). These are in some cases applicable to either saturated or superheated steam.

SATURATED STEAM

358. Thermodynamics of Vapors. The remainder of this text is chiefly concerned with the phenomena of vapors and their application in vapor engines and refrigerating machines. The behavior of vapors during heat changes is more complex than that of perfect gases. The temperature of boiling is different for different vapors, even at the same pressure; but the following laws hold for all other vapors as well as for that of water:

- (1) The temperatures of the liquid and of the vapor in contact with it are the same ;
- (2) The temperature of a specific saturated vapor at a specified pressure is always the same ;
- (3) The temperature and the density of a vapor remain constant during its formation from liquid at constant pressure ;
- (4) Increase of pressure increases the temperature and the density of the vapor ; *
- (5) Decrease of pressure lowers the temperature and the density ;
- (6) The temperature can be increased and the density can be decreased at will, at constant pressure, when the vapor is not in contact with its liquid ;
- (7) If the pressure upon a saturated vapor be increased without allowing its temperature to rise, the vapor must condense ; it cannot exist at the increased pressure *as vapor* (Art. 356). If the pressure is lowered while the temperature remains constant, the vapor becomes superheated.

359. Effects of Heat in the Formation of Steam. Starting with a pound of water at 32° F., as a convenient reference point, the heat expended during the formation of saturated steam at any temperature and pressure is utilized in the following ways :

- (1) h units in the *elevation of the temperature of the water*. If the specific heat of water be unity, and t be the boiling point, $h = t - 32$; actually, h always slightly exceeds this, but the excess is ordinarily small. †‡

* Since mercury boils, at atmospheric pressure, at 675° F., common thermometers cannot be used for measuring temperatures higher than this ; but by filling the space in the thermometric tube above the mercury with gas at high pressure, the boiling point of the mercury may be so elevated as to permit of its use for measuring flue gas temperatures exceeding 800° F.

† According to Barnes' experiments (8), the specific heat of water decreases from 1.0094 at 32° F. to 0.99735 at 100° F., and then steadily increases to 1.0476 at 428° F.

‡ In precise physical experimentation, it is necessary to distinguish between the value of h measured above 32° F. and *atmospheric pressure*, and that measured above 32° F. and the corresponding *pressure of the saturated vapor*. This distinction is of no consequence in ordinary engineering work.

$$(2) \frac{p(V-v)}{778} \text{ units in the expansion of the water (external work), } p$$

being the pressure per square foot and v and V the initial and final specific volumes of the water respectively. This quantity is *included* in item h , as above defined; it is so small as to be usually negligible, and the total heat required to bring the water up to the boiling point is regarded as an **internal energy change**.

$$(3) e = \frac{p(W-V)}{778} \text{ units to perform the external work of increasing}$$

the volume at the boiling point from that of the water to that of the steam, W being the specific volume of the steam.

$$(4) r \text{ units to perform the disgregation work of this change of state}$$

(Art. 15); items (3) and (4) being often classed together as L .

The total heat expended per pound is then

$$H = h + L = h + r + e = E + e.$$

The values of these quantities vary widely with different vapors, even when at the same temperature and pressure; in general, as the pressure increases, h increases and L decreases. Watt was led to believe (erroneously) that the sum of h and L for steam was a constant; a result once described as expressing "Watt's Law." This sum is now known to slowly increase with increase of pressure.

360. Properties of Saturated Steam. It has been found experimentally that as p , the pressure, increases, t , h , e , and H increase, while r and L decrease. These various quantities are tabulated in what is known as a **steam table**.*

* Regnault's experiments were the foundation of the steam tables of Rankine (9), Zeuner (10), and Porter (11). The last named have been regarded as extremely accurate, and were adopted as standard for use in reporting trials of steam boilers and pumping engines by the American Society of Mechanical Engineers. They do not give all of the thermal properties, however, and have therefore been unsatisfactory for some purposes. The tables of Dwelshauwers-Dery (12) were based on Zeuner's; Buel's tables, originally published in Weisbach's *Mechanics* (13), on Rankine's. Peabody's tables are computed directly from Regnault's work (14). The principal differences in these tables were due to some uncertainty as to the specific volume of steam (15). The precise work of Holborn and Henning (16) on the pressure-temperature relation and the adaptation by Davis (17) of recent experiments on the specific heat of superheated steam to the determination of the total heat of saturated steam (Art. 388) have suggested the possibility of steam tables of greater accuracy. The most recent and satisfactory of these is that of Marks and Davis (18), values from which are adopted in the remainder of the present text. (See pp. 247, 248.)

Our original knowledge of these values was derived from the comprehensive experiments of Regnault, whose empirical formula for the total heat of saturated steam was $H = 1081.94 + 0.305t$. The recent investigations of Davis (17) show, however, that a more accurate expression is

$$H = 1150.3 + 0.3745(t - 212) - 0.00055(t - 212)^2 \text{ (Art. 388).}$$

(The total heat at 212° F. is represented by the value 1150.3.) Barnes' and other determinations of the specific heat of water permit of the computation of h ; and $L = H - h$. The value of e may be directly calculated if the volume W is known, and $r = L - e$. The value of r has a straight line relation, approximately, with the temperature. This may be expressed by the formula $r = 1061.3 - 0.79 t^\circ \text{ F.}$ The method of deriving the steam volume, always tabulated with these other thermal properties, will be considered later. When saturated steam is condensed, all of the heat quantities mentioned are emitted in the reverse order, so to speak. Regnault's experiments were in fact made, not by measuring the heat absorbed during evaporation, but that emitted during condensation. Items h and r are both internal energy effects; they are sometimes grouped together and indicated by the symbol E ; whence $H = E + e$. The change of a liquid to its vapor furnishes the best possible example of what is meant by **disgregation work**. If there is any difficulty in conceiving what such work is, one has but to compare the numerical values of L and r for a given pressure. What becomes of the difference between L and e ? The quantity L is often called the **latent heat**, or, more correctly, the **latent heat of evaporation**. The "heat in the water" referred to in the steam tables is h ; the "heat in the steam" is H , also called the **total heat**.

361. Factor of Evaporation. In order to compare the total expenditures of heat for producing saturated steam under unlike conditions, we must know the temperature T , other than 32° F. (Art. 359), at which the water is received, and the pressure p at which steam is formed; for as T increases, h decreases; and as p increases, H increases. This is of much importance in comparing the results of steam boiler trials. At 14.7 lb. (atmospheric) pressure, for example, with water **initially at the boiling point**, 212° F., $h = 0$ and $H = L = 970.4$ (from the table, p. 247). These are the conditions adopted as standard, and with which actual evaporative performances

are compared. Evaporation under these conditions is described as being

From (a feed water temperature of) and at (a pressure corresponding to the temperature of) **212° F.**

Thus, for $p = 200$, we find $L = 843.2$ and $h = 354.9$; and if the temperature of the water is initially 190° F. , corresponding to the heat contents of 157.9 B. t. u. ,

$$H = L + (354.9 - 157.9) = 843.2 + 197 = 1040.2.$$

The ratio of the total heat actually utilized for evaporation to that necessary "from and at 212° F. " is called the factor of evaporation. In this instance, it has the value $1040.2 \div 970.4 = 1.07$. Generally, if L, h refer to the assigned pressure, and h_0 is the heat corresponding to the assigned temperature of the feed water, then the factor of evaporation is

$$F = [L + (h - h_0)] \div 970.4.$$

362. Pressure-temperature Relation. Regnault gave, as the result of his exhaustive experiments, thirteen temperatures corresponding to known pressures at saturation. These range from -32° C. to 220° C. He expressed the relation by four formulas (Art. 19); and no less than fifty formulas have since been devised, representing more or less accurately the same experiments. The determinations made by Holborn and Henning (16) agree closely with those of Regnault; as do those by Wiebe (19) and Thiesen and Scheel (20) at temperatures below the atmospheric boiling point.

The steam table shows that, beginning at 32° F. , the pressure rises with the temperature, at first slowly and afterward much more rapidly. The fact that slight increases of temperature accompany large increases of pressure in the working part of the range seems fatal to the development of the engine using saturated steam, the high temperature of heat absorption shown by Carnot to be essential to efficiency being unattainable without the use of pressures mechanically objectionable.

A recent formula for the relation between pressure and temperature is (*Power*, March 8, 1910)

$$t = 200 p^{\frac{1}{6}} - 102,$$

in which t is the Fahrenheit temperature and p the pressure in pounds per square inch. This has an accuracy within 1° or so for usual ranges.

Marks gives (*Jour. A. S. M. E.*, XXXIII, 5) the equation,

$$\log p = 10.515354 - \frac{4873.71}{T} - 0.00405093 T + 0.000001392964 T^2,$$

T being absolute and p in pounds per square inch. This has an established accuracy within $\frac{1}{3}$ of 1 per cent for the whole range of possible temperatures.

363. Pressure and Volume. Fairbairn and Tate ascertained experimentally in 1860 the relation between pressure and volume at a few points; some experiments were made by Hirn; and Battelli has reported results which have been examined by Tumlirz (21) who gives

$$v+c=\frac{BT}{p},$$

where p is in pounds per square inch, $c=0.256$, $B=0.5962$ and T is in degrees absolute.

More recent experiments by Knoblauch, Linde, and Klebe (1905) (22) give the formula

$$pv=0.5962 T-p(1+0.0014 p)\left(\frac{150,300,000}{T^3}-0.0833\right),$$

in which p is in pounds per square inch, v in cubic feet per pound, and T in degrees absolute.

Goodenough's modified form of this equation is more convenient:

$$v+c=\frac{BT}{p}-(1+ap)\frac{m}{T^n},$$

in which $B=0.5963$, $\log m=13.67938$, $n=5$, $c=0.088$, $a=0.0006$.

A simple empirical formula is that of Rankine, $PV^{1\frac{7}{6}} = \text{constant}$, or that of Zeuner, $PV^{1.0646} = \text{constant}$. These forms of expression must not be confused with the $PV^n = c$ equation for various polytropic paths. An indirect method of determining the volume of saturated steam is to observe the value of some thermal property, like the latent heat, per pound and per cubic foot, at the same pressure.

The incompleteness of experimental determinations, with the difficulty in all cases of ensuring experimental accuracy, have led to the use of analytical methods (Art. 368) for computing the specific volume. The values obtained agree closely with those of Knoblauch, Linde, and Klebe.

364. Wet Steam. Even when saturated steam is separated from the mass of water from which it has been produced, it nearly always contains traces of water in suspension. The presence of this water produces what is described as **wet steam**, the wetness being an indication of incomplete evaporation. Superheated steam, of course, cannot be wet. Wet steam is still saturated steam (Art. 356); the temperature and density of the steam are not affected by the presence of water.

The suspended water must be at the same temperature as the steam; it therefore contains, per pound, adopting the symbols of Art. 359, h units of heat. In the total mixture of steam and water, then, the proportion of steam being x , we write for L , xL ; for r , xr ; for e , xe ; for E , $xr + h$; while, h remaining unchanged, $H = h + xL$,

The factor of evaporation (Art. 361), wetness considered, must be correspondingly reduced; it is $F = [xL + (h - h_0)] \div 970.4$.

The specific volume of wet steam is $W_w = V + x(W - V) = xZ + V$, where $Z = W - V$. For dry steam, $x = 1$, and $W_w = V + (W - V) = W$. The error involved in assuming $W_w = xW$ is usually inconsiderable, since the value of V is comparatively small.

365. Limits of Existence of Saturated Steam. In Fig. 160, let ordinates represent temperatures, and abscissas, volumes. Then ab is a line representing possible conditions of water as to these two properties, which may be readily plotted if the specific volumes at various temperatures are known; and cd is a similar line for steam, plotted from the values of W and t in the steam table. The lines ab and cd show a tendency to meet (Art. 379). The curve cd is called the **curve of saturation**, or of **constant steam weight**; it represents all possible conditions of constant weight of steam, remaining saturated. It is *not* a path, although the line ab is (Art. 363). States along ab are those of liquid; the area $badc$ includes all wet saturated states; along dc , the steam is dry and saturated; to the right of dc , areas include *superheated states*.

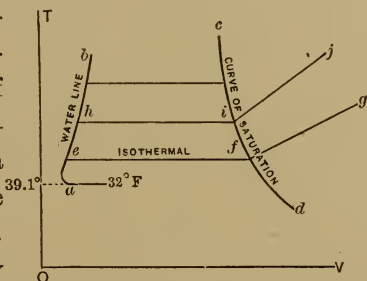

FIG. 160. Arts. 365, 366, 379. — Paths of Steam Formation.

366. Path during Evaporation. Starting at 32°, the path of the substance during heating and evaporation at constant pressure would be any of a series of lines aef , ahi , etc. The curve ab is sometimes called the **locus of boiling points**. If superheating at constant pressure occur after evaporation, then (assuming Charles' law to hold) the paths will continue as fg , ij , straight lines converging at O . For a saturated vapor, wet or dry, the *isothermal* can only be a straight line of constant pressure.

367. Entropy Diagram. Figure 161 reproduces Fig. 160 on the entropy plane. The line ab represents the heating of the water at constant pressure. Since the specific heat is slightly variable, the

increase of entropy must be computed for small differences of temperature. The more complete steam tables give the entropy at various boiling points, measured above 32°. Let evaporation occur when the

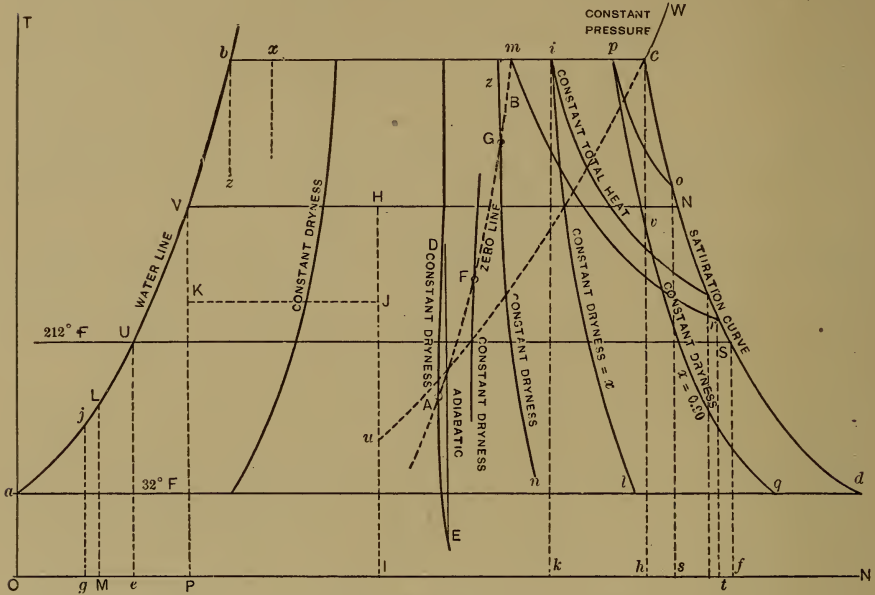

FIG. 161. Arts. 367, 369-373, 376, 379, 386, 426. — The Steam Dome.

temperature is T_b . The increase of entropy from the point b (since the temperature is constant during the formation of steam at constant pressure) is simply $L \div (T_b + 459.6)$, which is laid off as bc . Other points being similarly obtained, the saturation curve cd is drawn. The paths from liquid at 32° to dry saturated steam are abc , aVN , aUS , etc.

The factor of evaporation may be readily illustrated. Let the area $eUSf$ represent L_{212} , the heat necessary to evaporate one pound from and at 212° F. The area $gjbch$ represents the heat necessary to evaporate one pound at a pressure b from a feed-water temperature j . The factor of evaporation is $gjbch \div eUSf$. For wet steam at the pressure b , it is, for example, $gjbik \div eUSf$.

368. Specific Volumes: Analytical Method. This was developed by Clapeyron in 1834. In Fig. 162, let $abcd$ represent a Carnot cycle in which steam is the working substance and the range of temperatures is dT . Let the substance be liquid along da and dry saturated vapor along bc .

The heat area $abfe$ is L ; the work area $abcd$ is $(L + T)dT$. In Fig. 163, let $abcd$ represent the corresponding work area on the pv diagram. Since the range of temperatures is only dT , the range of pressures may be

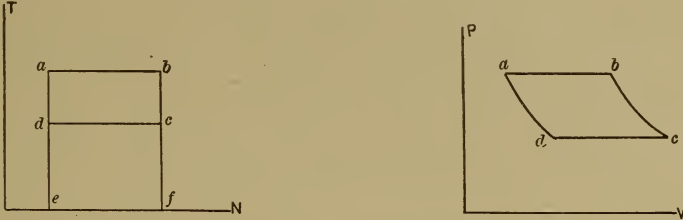

Figs. 162 and 163. Arts. 368, 406, 603. — Specific Volumes by Clapeyron's Method.

taken as dP ; whence the area $abcd$ in Fig. 163 is $dP(W - V)$, where W is the volume along bc , and V that along ad . This area must by the first law of thermodynamics equal $(778 L \div T)dT$; whence

$$W - V = \frac{778 L}{T} \cdot \frac{dT}{dP} \text{ and } W = V + \frac{778 L dT}{T \cdot dP}.$$

Thus, if we know the specific volume of the liquid, and the latent heat of vaporization, at a given temperature, we have only to determine the differential coefficient $\frac{dT}{dP}$ in order to compute the specific volume of the vapor. The value of this coefficient may be approximately estimated from the steam table; or may be accurately ascertained when any correct formula for relation between P and T is given. The advantage of this indirect method for ascertaining specific volumes arises from the accuracy of experimental determinations of T , L , and P .

369. Entropy Lines. In Fig. 161, let ab be the water line, cd the saturation curve; then since the horizontal distance between these lines at any absolute temperature T is equal to $L \div T$, we deduce that, for steam only partially dry, the gain of heat in passing from the water line toward cd being xL instead of L , the gain of entropy is $xL \div T$ instead of $L \div T$. If on bc and ad we lay off bi and $al = x \cdot bc$ and $x \cdot ad$, respectively, we have two points on the constant dryness curve il , along which the proportion of dryness is x . Additional points will fully determine the curve. The additional curves zn , pq , etc., are similarly plotted for various values of x , all of the horizontal intercepts between ab and cd being divided in the same proportions by any one of these curves.

370. Constant Heat Curves. Let the total heat at o be H . To find the state at the temperature bc , at which the total heat may also equal H , we remember that for wet steam $H = h + xL$, whence $x = (H - h) \div L = bp \div bc$. Additional points thus determined for this and other assigned values of H give the **constant total heat curves** op , mr , etc. The total heat of saturated vapor is not, however, a cardinal property (Art. 10). The state points on this diagram determine the heat contents only on the assumption that *heat has been absorbed at constant pressure*; along such paths as abc , aUS , aVN , etc.

371. Negative Specific Heat. If steam passes from o to r , Fig. 161, heat is **absorbed** (area *sort*) while the temperature decreases. Since the saturation curve slopes constantly downward toward the right, the specific heat of steam **kept saturated** is therefore **negative**. The specific heat of a vapor can be positive only when the saturation curve slopes downward to the left, like cu , as in the case, for example, of the vapor of ether (Fig. 315). The conclusion that the specific heat of saturated steam is negative was reached independently by Rankine and Clausius in 1850. It was experimentally verified by Hirn in 1862 and by Cazin in 1866 (24). The physical significance is simply that when the temperature of dry saturated steam is increased adiabatically, it becomes superheated; heat must be abstracted to keep it saturated. On the other hand, when dry saturated steam expands, the temperature falling, it tends to condense, and heat must be supplied to keep it dry. If steam at c , Fig. 161, having been formed at constant pressure, works along the saturation curve to N , its heat contents are *not the same* as if it had been formed along aVN , but are greater, being greater also than the "heat contents" at c .

372. Liquefaction during Expansion. If saturated steam expand adiabatically from c , Fig. 161, it will at v have become 10 per cent wet. If its temperature increase adiabatically from v , it will at c have become dry. If the adiabatic path then continue, the steam will become superheated. Generally speaking, liquefaction accompanies expansion and drying or superheating occurs during compression. If the steam is very wet to begin with, say at the state x , compression may, however, cause liquefaction, and expansion may lead to drying. Water expanding adiabatically (path bz) becomes partially vaporized. Vapors may be divided into two classes, depending upon whether they liquefy or dry during adiabatic expansion under ordinary conditions of initial dryness. At usual stages of dryness and temperature, steam liquefies during expansion, while ether becomes dry, or superheated.

373. Inversion. Figure 161 shows that when x is about 0.5 the constant dryness lines change their direction of curvature, so that it is possible for a single adiabatic like DE to twice cut the same dryness curve; x may therefore have the same value at the beginning and end of expansion, as at D and E . Further, it may be possible to draw an adiabatic which is tangent to the dryness curve at A . Adiabatic expansion below A tends to liquefy the steam; above A , it tends to dry it. During expansion along the dryness curve below A , the specific heat is *negative*; above A , it is *positive*. By finding other points like A , as F, G , on similar constant dryness curves, a line BA may be drawn, which is called the *zero line* or *line of inversion*. During expansion along the dryness lines, the specific heat becomes zero at their intersection with AB , where they become tangent to the adiabatics. If the line AB be projected so as to meet the extended saturation curve dc , the point of intersection is the *temperature of inversion*. There is no temperature of inversion for dry steam (Art. 379), the saturation curve reaching an upper limit before attaining a vertical direction.

374. Internal Energy. In Fig. 164, let 2 be the state point of a wet vapor. Lay off 24 vertically, equal to $(T \div L)(L - r)$. Then 1243 (34 being drawn horizontally and 13 vertically) is equal to

$$12 \times 24 = \frac{xL}{T} \cdot \frac{T}{L}(L - r) = x(L - r).$$

This quantity is equal to the *external work of vaporization* = xe , which is accordingly represented by the area 1243. The irregular area 651347 then represents the *addition of internal energy*, 6518 having been expended in heating the water, and 8347 = xr being the disgregation work of vaporization.

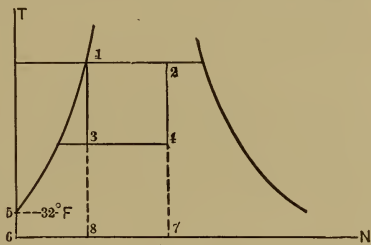

FIG. 164. Art. 374. — Internal Energy and External Work.

375. External Work. Let MN , Fig. 165, be any path in the saturated region. The heat absorbed is $mMNn$. Construct $Mcba$, $Nfed$, as in Art. 374. The internal energy has increased from $Oabcm$ to $Odefn$, the amount of increase being $adefnmcb$. This is greater than the amount of heat absorbed, by $deiMcba - iNf$, which difference consequently measures the external work done upon the substance. Along some such curve as XY , it will be found that external work has been done by the substance.

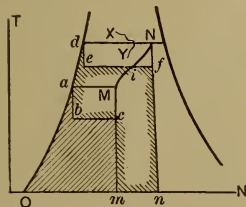

FIG. 165. Art. 375. — Internal Energy of Steam.

376. The Entropy Diagram as a Steam Table. In Fig. 161, let the state point be H . We have $T = HI$, from which P may be found. HJ is made equal to $(T \div L)(L - r)$, whence $OaVKJI = E$ and $VHJK = xe$. Also $x = VH \div VN$, the entropy measured from the water line is VH , the momentary specific heat of the water along the differential path jL is $qjLM \div T_j$; $xL = PVIII$, $xr = KJIP$, $h = OaVP$, and $H = OaVHI$. The specific volume is still to be considered.

377. Constant Volume Lines. In Fig. 166, let JA be the water line, BG the saturation curve, and let vertical distances below ON represent specific volumes. Let xs equal the volume of boiling water, sensibly constant, and of comparatively small numerical value, giving the line ss .

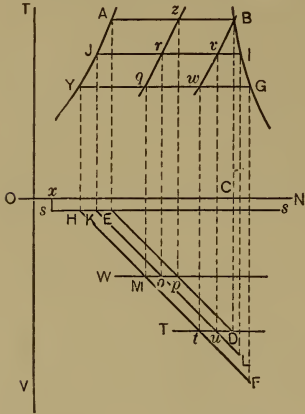

FIG. 166. Art. 377.—Constant Volume Lines.

From any point B on the saturation curve, draw BD vertically, making CD represent by its length the specific volume at B . Draw BA horizontally, and AE vertically, and connect the points E and D . Then ED shows the relation of volume of vapor and entropy of vapor, along AB , the two increasing in arithmetical ratio. Find the similar lines of relation KL and HF for the temperature lines JI and YG . Draw the constant volume line TD , and find the points on the entropy plane w, v, B , corresponding to t, u, D . The line of constant volume wB may then be drawn, with similar lines for other specific volumes, qz , etc. The plotting of such lines on the entropy plane permits of the use of this diagram for obtaining specific volumes (see Fig. 175).

378. Transfer of Vapor States. In Fig. 167, we have a single representation of the four coördinate planes pt, tn, nv , and pv . Let ss be the line of water volumes, ab and ef the saturation curve, Cd the pressure-temperature curve (Art. 362), and Op the water line. To transfer points a, b on the saturation curve from the pv to the tn plane, we have only to draw aC, Ce, bd , and df . To transfer points like i, l , representing wet states, we first find the vn lines qh and rg as in Art. 377, and then project ij, jk, lm , and mn (25).

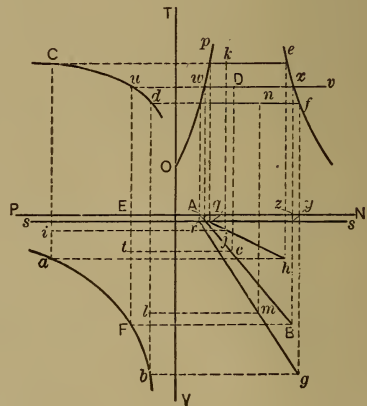

FIG. 167. Art. 378.—Transfer of Vapor States.

From any point B on the saturation curve, draw BD vertically, making CD represent by its length the specific volume at B . Draw BA horizontally, and AE vertically, and connect the points E and D . Then ED shows the relation of volume of vapor and entropy of vapor, along AB , the two increasing in arithmetical ratio. Find the similar lines of relation KL and HF for the temperature lines JI and YG . Draw the constant volume line TD , and find the points on the entropy plane w, v, B , corresponding to t, u, D . The line of constant volume wB may then be drawn, with similar lines for other specific volumes, qz , etc. The plotting of such lines on the entropy plane permits of the use of this diagram for obtaining specific volumes (see Fig. 175).

Consider any point t on the pv plane. By drawing tu and uv we find the vertical location of this point in the tn plane. Draw wA and xB , making zB equal to the specific volume of vapor at x (equal to EF on the pv plane). Draw AB and project t to e . Projecting this last point upward, we have D as the required point on the entropy plane.

379. Critical Temperature. The water curve and the curve of saturation in Figs. 160 and 161 show a tendency to meet at their upper extremities. Assuming that they meet, what are the physical conditions at the **critical temperature** existing at the point of intersection? It is evident that here $L = 0$, $r = 0$, and $e = 0$. The substance would pass immediately from the liquid to the superheated condition; there would be no intermediate state of saturation. No external work would be done during evaporation, and, conversely, no expenditure of external work could cause liquefaction. A vapor cannot be liquefied, when above its critical temperature, by any pressure whatsoever. The density of the liquid is here the same as that of the vapor: the two states cannot be distinguished. The pressure required to liquefy a vapor increases as the critical temperature is approached (moving upward) (Arts. 358, 360); that necessary at the critical temperature is called the **critical pressure**. It is the vapor pressure corresponding to the temperature at that point. The volume at the intersection of the saturation curve and the liquid line is called the **critical volume**. The "specific heat of the liquid" at the critical temperature is infinity.

The critical temperature of carbon dioxide is 88.5° F. This substance is sometimes used as the working fluid in refrigerating machines, particularly on shipboard. It cannot be used in the tropics, however, since the available supplies of cooling water have there a temperature of more than 88.5° F., making it impossible to liquefy the vapor. The carbon dioxide contained in the microscopic cells of certain minerals, particularly the topaz, has been found to be in the critical condition, a line of demarcation being evident, when cooling was produced, and disappearing with violent frothing when the temperature again rose. Here the substance is under critical pressure; it necessarily condenses with lowering of temperature, but cannot remain condensed at temperatures above 88.5° F. Avenarius has conducted experiments on a large scale with ether, carbon disulphide, chloride of carbon, and acetone, noting a peculiar coloration at the critical point (26).

For steam, Regnault's formula for H (Art. 360), if we accept the approximation $h = t - 32^{\circ}$, would give $L = H - h = 1113.94 - 0.695t$, which becomes zero when $t = 1603^{\circ}$ F. Davis' formula (Art. 360) (likewise not intended to apply to temperatures above about 400° F.) makes $L = 0$ when $t = 1709^{\circ}$ F. The critical temperature for steam has been experimentally ascertained to be actually much lower, the best value being about 689° F. (27). Many of the important vapors have been studied in this direction by Andrews.

380. Physical States. We may now distinguish between the gaseous conditions, including the states of saturated vapor, superheated vapor, and true gas. A *saturated vapor*, which *may be either dry or wet*, is a gaseous substance at its *maximum density* for the given temperature or pressure; and *below the critical temperature*. A *superheated vapor* is a gaseous substance at *other than maximum density* whose temperature is either less than, or *does not greatly exceed, the critical temperature*. At *higher temperatures*, the substance becomes a *true gas*. All *imperfect gases* may be regarded as *superheated vapors*.

Air, one of the most nearly perfect gases, shows some deviations from Boyle's law at pressures not exceeding 2500 lb. per square inch. Other substances show far more marked deviations. In Fig. 168, *QP* is an equilateral hyperbola. The isothermals for air at various temperatures centi-

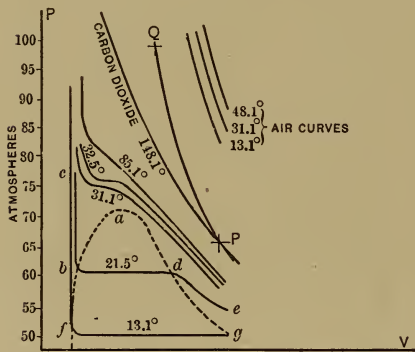

FIG. 168. Art. 380. — Critical Temperature.

grade are shown above. The lower curves are isotherms for carbon dioxide, as determined by Andrews (28). They depart widely from the perfect gas isothermal, *PQ*. The dotted lines show the liquid curve and the saturation curve, running together at *a*, at the critical temperature. There is an evident increase in the irregularity of the curves as they approach the critical temperature (from above) and pass below it. The curve for 21.5° C. is particularly interesting. From *b* to *c* it is a liquid curve, the volume remaining practically constant at constant temperature in spite of enormous changes of pressure. From *b* to *d* it is a nearly straight horizontal line, like that of any vapor between the liquid and the dry saturated states; while from *d* to *e* it approaches the perfect gas form, the equilateral hyperbola. All of the isothermals change their direction abruptly whenever they approach either of the limit curves *af* or *ag*.

381. Other Paths of Steam Formation. The discussion has been limited to the formation of steam at constant pressure, the method of practice. Steam might conceivably be formed along any arbitrary path, as for instance in a closed vessel at constant volume, the pressure steadily increasing. Since the change of internal energy of a substance depends upon its initial and final states only, and not on the intervening path, a change of path affects the external work only. For formation at constant volume, the total heat equals *E*, no external work being done. If in Fig. 169 water at *c* could be com-

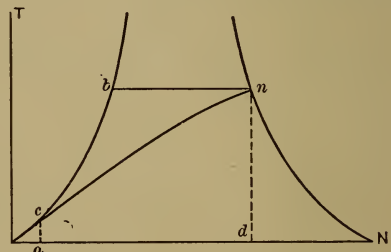

FIG. 169. Art. 381. — Evaporation at Constant Volume.

pletely evaporated along cn at *constant volume*, the area $acnd$ would represent the addition of internal energy and the total heat received. If the process be at *constant pressure*, along cbn , the area $acnd$ represents the total heat received and the area cbn represents the external work done.

382. Vapor Isodynamic. A saturated vapor contains heat above 32° F. equal to $h + r + e$; or, at some other state, to $h_1 + r_1 + e_1$. If the two states are isodynamic (Art. 83), $h + r = h_1 + r_1$, a condition which is impossible if at both states the steam be dry. If the steam be wet at both states, $h + xr = h_1 + x_1r_1$. Let p , p_1 , v be given; and let it be required to find v_1 , the notation being as in Art. 364. We have $x_1 = \frac{h + xr - h_1}{r_1}$, all of these quantities being known or readily ascertainable. Then

$$v_1 = V_1 + x_1(W_1 - V_1) = x_1Z_1 + V_1 = V_1 + \frac{Z_1}{r_1}(h + xr - h_1).$$

If $x = 1.0$, the steam being dry at one state, $x_1 = \frac{h + r - h_1}{r_1}$ and

$$v_1 = V_1 + \frac{Z_1}{r_1}(h + r - h_1).$$

Substitution of numerical values then shows that if p exceed p_1 , v is less than v_1 ; *i.e.* the curve slopes upward to the left on the pv diagram: and x is less than x_1 . The curve is less "steep" than the saturation curve. *Steam cannot be worked isodynamically and remain dry*; each isodynamic curve meets the saturation curve at a single point.

382a. Sublimation. It has been pointed out that a vapor cannot exist at a temperature below that which "corresponds" to its pressure. It is likewise true that a substance cannot exist in the *liquid* form at a temperature *above* that which "corresponds" to its pressure. When a substance is melted in air, it usually becomes a liquid; and if a further addition of heat occurs it will at some higher temperature become a vapor. If, however, the saturation pressure at the melting temperature exceeds the pressure of the atmosphere, then at atmospheric pressure the saturation temperature is less than the melting temperature, and the substance cannot become a liquid, because we should then have a liquid at a higher temperature than that which corresponds to its pressure. Sublimation (Art. 17), the direct passage from the solid to vaporous condition, occurs because the atmospheric boiling point is below the atmospheric melting point.

Water at 32° has a saturation pressure of 0.0886 lb. per square inch. If the moisture in the air has a lower partial pressure than this, ice cannot be melted, but will sublime, because water as a liquid cannot exist at 32° at a less pressure than 0.0886.

THERMODYNAMICS OF GAS AND VAPOR MIXTURES

382b. Gas Mixture. (See Art. 52 b.) When two gases, weighing w_1 and w_2 lb. respectively, together occupy the same space at the conditions p , v , t , we may write the characteristic equations, using subscripts to represent the different gases, conforming to Dalton's law,

$$p_1v = R_1tw_1, \quad p_2v = R_2tw_2, \quad p_1 + p_2 = p, \quad w_1 + w_2 = w.$$

WEIGHTS OF AIR, VAPOR OF WATER, AND SATURATED MIXTURES OF AIR AND VAPOR AT DIFFERENT TEMPERATURES, UNDER THE ORDINARY ATMOSPHERIC PRESSURE OF 29.921 INCHES OF MERCURY.

Temperature Fahrenheit	MIXTURES OF AIR SATURATED WITH VAPOR		
	Elastic Force of the Air in the Mixture of Air and Vapor in ins. of Mercury	Weight of Cubic Foot of the Mixture of Air and Vapor	
		Weight of the Air in Pounds	Weight of the Vapor in Pounds
0°	29.877	.0863	.000079
12	29.849	.0840	.000130
22	29.803	.0821	.000202
32	29.740	.0802	.000304
42	29.654	.0784	.000440
52	29.533	.0766	.000627
62	29.365	.0747	.000881
72	29.136	.0727	.001221
82	28.829	.0706	.001667
92	28.420	.0684	.002250
102	27.885	.0659	.002997
112	27.190	.0631	.003946
122	26.300	.0599	.005142
132	25.169	.0564	.006639
142	23.756	.0524	.008475
152	21.991	.0477	.010716
162	19.822	.0423	.013415
172	17.163	.0360	.016682
182	13.961	.0288	.020536
192	10.093	.0205	.025142
202	5.471	.0109	.030545
212	0.000	.0000	.036820

These yield as the equation of the mixture,

$$pv = Rtw,$$

where $R = (R_1w_1 + R_2w_2) \div (w_1 + w_2)$. For pure dry air, containing by weight 0.77 nitrogen to 0.23 oxygen, the value of R should then be

$$(48.2 \times 0.23) + (54.9 \times 0.77) = 53.2.$$

382c. Air and Steam. We are apt to think of the minimum boiling point of water (except in a vacuum) as 212° F. But water will boil at temperatures as low as 32° F. under a definite low partial pressure for each temperature. Thus at 40° F., if an adequate amount of moisture is exposed to the normal atmosphere it will

be vaporized until the mixture of air and steam contains the latter at a partial pressure of 0.1217 lb. per square inch, the partial pressure of the air then being only 14.697-0.1217=14.5753 lb. per square inch. Such air is *saturated*. If there is a scant supply of moisture, the partial pressure of vapor will be less than that corresponding with its temperature, and such vapor as is evaporated will be superheated. The weight of moisture in a cubic foot of saturated air is the tabular density of the vapor at its temperature. What is commonly called the *absolute humidity* of air may be expressed either in terms of the weight of vapor per cubic foot of mixture or of the partial vapor pressure.

The weight of gas or superheated vapor in any assigned space at any stated temperature is directly proportional to the partial pressure thereof. The *relative humidity* of moist air may therefore be expressed either as $\frac{w}{W}$ or as $\frac{p_2}{P_2}$, where w and

W are respectively the weights of water vapor in a cubic foot of moist air, unsaturated and saturated, and p_2, P_2 are the corresponding partial pressures. The value of R in the characteristic equation is obtained, for moist air at a relative humidity below 1.0, by the method of the first paragraph, using for the water vapor $R_2=85.8$.

If the air temperature is 92° F., and a wick-covered ("wet bulb") thermometer reads 82°, the partial pressure of the vapor is that corresponding with saturation at 82°, that is, 0.539 lb. per square inch; for the air about the wet-bulb thermometer is saturated, evaporation from the moist wick causing the cooling. *Saturated* air at 92° would have a partial vapor pressure of 0.741 lb. per square inch. The air in question has therefore a relative humidity of $\frac{0.539}{0.741}=0.73$. The value of R for this air is not 53.2, but

$$\frac{R_1 w_1 + R_2 w_2}{w_1 + w_2} = \frac{R_1 w_1 \left(1 + \frac{R_2 w_2}{R_1 w_1}\right)}{w_1 \left(1 + \frac{w_2}{w_1}\right)} = \frac{53.2 + 0.069 \left(1 + \frac{85.8 \cdot 0.539}{53.2 \cdot 14.158}\right)}{0.069 \left(1 + \frac{0.539}{14.158}\right)} = 54.5,$$

a subordinate relation being

$$w_1 = \frac{p_1}{R_1 t} = \frac{(14.697 - 0.539)144}{53.2 \times 552} = 0.069.$$

If the respective specific heats are k_1 and k_2 , then the specific heat of the mixture is

$$k = \frac{k_1 w_1 + k_2 w_2}{w_1 + w_2} = \frac{w_1 \left(k_1 + k_2 \frac{w_2}{w_1}\right)}{w_1 \left(1 + \frac{w_2}{w_1}\right)} = \frac{k_1 + k_2 \frac{p_2}{p_1}}{1 + \frac{p_2}{p_1}},$$

which for our conditions, with $k_1=0.2375, k_2=0.4805$, gives $k=0.248$.

382d. Thermodynamic Equations. When dealing with mixtures of wet vapors, or of wet vapors and air, the ordinary equations for expansion do not in general apply. This is the more unfortunate in that any general analysis of the subject must include consideration of expansion paths which will partially liquefy one or more of the constituents of even a wholly superheated mixture. The internal energies of the constituents and their entropies are dependent upon and may be computed from their thermal conditions alone, however; mixing

does not affect the energy, and adiabatic expansion does not affect the entropy; so that it is by no means impracticable to study the phenomena accompanying (a) the operation of mixing and (b) the expansion or compression of the mixture.

382c. Wet Vapor and Gas. As a simple case, consider a mixture of wet steam and air: the condition of a super-saturated atmosphere. Let such a mixture be at the state p, v, t ; the steam state being w_2, p_2, x_2 , and that of the air w_1, p_1 . Then $p = p_1 + p_2$, and $v = w_2 x_2 v_2 = \frac{R_1 t w_1}{p_1}$, where v_2 is the specific volume of the dry steam. The internal energy of the mixture is

$$E = E_1 + E_2 = l w_1 t + w_2 (h_2 + x_2 r_2),$$

where l is the specific heat of air at constant volume and h_2 and r_2 are tabular thermal properties at the pressure p_2 . The entropy of the mixture is

$$n = n_1 + n_2 = w_1 \left[l \log_e \frac{t}{492} + (k - l) \log_e \frac{v}{v_0} \right] + w_2 (n_w + x_2 n_s),$$

where k is the specific heat of air at constant pressure, v_0 is the volume of w_1 lb. of air under standard conditions and n_w and n_s are the entropies of steam at the pressure p_2 .

In an isothermal change of such mixture, E_1 remains constant and (the dryness of the steam changing to x_3) E_2 increases by $w_2 r_2 (x_3 - x_2)$. The air conforms to its usual characteristic equation, $p_1 v_1 = R t_1$. In reaching the expanded volume v_3 , the external work done by the air is then

$$p_1 v \log_e \frac{v_3}{v}.$$

The steam remaining wet expands at constant pressure, and does the external work $p_2 (v_3 - v)$, so that the whole amount of external work done is

$$W = p_1 v \log_e \frac{v_3}{v} + p_2 (v_3 - v).$$

The heat absorbed may be expressed as the sum of the external work done and the internal energy gained; or as

$$H = p_1 v \log_e \frac{v_3}{v} + p_2 (v_3 - v) + w_2 r_2 (x_3 - x_2) = p_1 v \log_e \frac{v_3}{v} + w_2 l_2 (x_3 - x_2),$$

where l_2 is the latent heat of vaporization corresponding with the pressure p_2 . Alternatively, the heat absorbed is equal to the product of the temperature by the increase of entropy; or

$$H = t \left[w_1 (k - l) \log_e \frac{v_3}{v} + w_2 n_e (x_3 - x_2) \right] = p_1 v \log_e \frac{v_3}{v} + l_2 w_2 (x_3 - x_2),$$

as before; $n_e = \frac{l_2}{t}$ being the entropy of vaporization at the pressure p_2 . Let it be

noted also that $v_3 = w_2 x_3 v_2 = \frac{R_1 t w_1}{p_3'}$, so that

$$\frac{v}{v_3} = \frac{x_2}{x_3} = \frac{p_3'}{p_1}, p_3' \text{ denoting the partial pressure of air in the mixture after expansion.}$$

The mixing of air with saturated steam produces a total pressure which is higher than the saturation pressure of steam at the given temperature. Such a mixture

may therefore be regarded as the reverse of superheated vapor, in which latter the pressure is less than that corresponding with the temperature.

In *adiabatic expansion*, let the final condition be x_3, t_3, p_3 . The entropy remaining constant,

$$w_1 k \log_e \frac{t_3}{t} + w_1(k-l) \log_e \frac{p_1}{p_3} + w_2(n_w' + x_3 n_e' - n_w - x_3 n_e) = 0,$$

where n_w is entropy of liquid and primes refer to final conditions. The partial pressure of the vapor is tabular for t_3 . If v_3' is the specific volume of steam for t_3 , then

$$w_2 x_3 v_3' = v_3, \quad p_3'' = \frac{w_1 R_1 t_3}{v_3},$$

$$x_3 = \frac{v_3}{v_3' w_2}, \quad p_3'' + p_3' = p_3, \quad x_3 = \frac{w_1 R_1 t_3}{p_3'' v_3' w_2},$$

where p_3'' and p_3' are the partial pressures of air and steam, respectively. The external work is written as the loss of internal energy, or, as

$$W = E - E_3 = w_1 l(t_3 - t) + w_2(h_2 + x_2 r_2 - h_3 - x_3 r_3).$$

382f. High Pressure Steam and Air. The pressure attained by mixing cannot exceed the initial pressure of the more compressed constituent. Assume 1 lb. of steam, 0.85 dry, at an absolute pressure of 200 lb., to be mixed with 2 lb. of air at 220 lb. pressure and 400° F. The respective volumes are

$$v_s = 0.85 \times 2.29 = 1.945; \quad v_a = \frac{53.4 \times 860 \times 2}{220 \times 144} = 2.9;$$

and the volume of mixture will be, under the usual condition of practice,

$$1.945 + 2.9 = 4.845.$$

The internal energy before (and after) mixing is

$$(2 \times 0.1689 \times 860) + 354.9 + (0.85 + 759.5) = 1288 \text{ B. t. u.}$$

This we put equal to $(2 \times 0.1689 \times t) + h_2 + x_2 r_2$; $x_2 = \frac{v}{v_2} = \frac{4.845}{v_2}$; and (assuming values of t) we find by trial and error,

$$0.3378t + h_2 + \frac{4.845r_2}{v_2} = 1288, \quad (1285)$$

$$t = 314(+460), \quad h_2 = 284, \quad r_2 = 818, \quad v_2 = 5.33, \quad x_2 = 0.908,$$

$$p_2 = 82.3, \quad p_1 = 118.2, \quad p = 200.5.$$

Mixing has caused an increase in dryness of steam, a *considerable reduction of temperature*, and a final pressure between the two original pressures.

The entropy of the mixture is now

$$2 \left\{ \left(0.1689 \times 2.3 \log \frac{774}{492} \right) + \left(0.0686 \times 2.3 \log \frac{4.845}{24.774} \right) \right\} \\ + 0.456 + (0.908 \times 1.1617) = 1.438$$

Let isothermal expansion increase the dryness to 0.95. The volume then becomes $0.95 \times 5.33 = 5.08 = v_3$. The external work done is

$$\frac{1}{778} \left\{ \left(144 \times 118.2 \times 4.845 \times 2.3 \log \frac{5.08}{4.85} \right) + 144 \times 82.3(5.08 - 4.845) \right\} = 8.45 \text{ B. t. u.}$$

The internal energy increases by $0.042 \times 759.5 = 31.9$ B. t. u., and the heat absorbed should then be $31.9 + 8.45 = 40.35$ B. t. u. The entropy in the expanded condition is

$$2 \left\{ \left(0.1689 \times 2.3 \log \frac{774}{492} \right) + \left(0.0686 \times 2.3 \log \frac{5.08}{24.774} \right) \right\} + 0.456 + (0.95 \times 1.1617) = 1.49,$$

and the check value for heat absorbed is $(460 + 314) \times (1.49 - 1.438) = 40.3$ B. t. u. The partial pressures after expansion are

$$\text{Air, } p_3' = p_1 \frac{x_2}{x_3} = 118.2 \frac{0.908}{0.950} = 113; \text{ and steam, } 82.3, \text{ as before.}$$

In the usual expression for external work,

$$W = \frac{pv - PV}{n-1}, \quad n = \frac{pv - PV + W}{W},$$

the equivalent value of n is

$$\frac{144\{(200.5 \times 4.845) - (195.3 \times 5.08)\} + (8.45 \times 778)}{8.45 \times 778} = 0.603.$$

Consider next the *adiabatic* expansion from the same initial condition to a temperature $t_3 = 50^\circ (+460)$; when $v_3' = 1702$, $p_3' = 0.178$, $n_w' = 0.0361$, $n_e' = 2.0865$, $v_3 = 1702x_3$. Then

$$1.438 = 2 \left\{ \left(0.1689 \times 2.3 \log \frac{510}{492} \right) + \left(0.0686 \times 2.3 \log \frac{1702x_3}{24.774} \right) \right\} + 0.0361 + 2.0865x_3,$$

and $x_3 = 0.47$, $v_3 = 802$.

The internal energy in the expanded condition is

$$18.08 + (0.47 \times 1007.3) + 2(0.1689 \times 510) = 665 \text{ B. t. u.},$$

and the external work done is $1288 - 665 = 623$ B. t. u. The steam expanding alone from its original condition would have had a final dryness of 0.65, and would have afforded external work amounting to

$$354.9 + (0.85 \times 759.5) - 18.08 - (0.65 \times 1007.3) = 323 \text{ B. t. u.}$$

The air expanding alone to 50° , according to the law $p_1 v_1^y = p_1' v_1'^y$ would have given

$$p_1' = p_1 \left(\frac{v_1}{v_1'} \right)^y = 220 \left(\frac{2.9}{802} \right)^{1.402} = 0.085,$$

$$W_1 = \frac{144}{778} \left(\frac{220 \times 2.9 - 0.085 \times 802}{0.402} \right) = 262 \text{ B. t. u.}$$

THERMODYNAMICS OF GAS AND VAPOR MIXTURES 251

The total work obtainable without mixture, down to the temperature $t_3=50$ would then have been $262+323=585$ B. t. u.

The equivalent value of n for the expansion of the mixture is

$$\frac{144\{(200.5 \times 4.845) - (0.263 \times 802)\} + (665 \times 778)}{665 \times 778} = 1.21.$$

Since y for steam initially 0.91 dry is 1.126, and y for air is 1.402, the value of n might perhaps have been expected to be about

$$\frac{(2 \times 1.402) + 1.126}{3} = 1.31.$$

382j. Superheated Steam and Air. If the steam is superheated, its initial volume is (from the Tumlirz equation, Art. 363),

$$v = w_2 v_s = w_2 \left(\frac{Bt}{p_2} - c \right),$$

where $B=0.5962$, $c=0.256$. The internal energy of superheated steam may be written as that at saturation ($h_2 + x_2 r_2$) plus that of superheating,

$$\frac{k_s}{y_s} (t - t_s),$$

where k_s is the specific heat of the superheated steam, $y_s=1.298$, and t_s is the saturation temperature for the partial pressure p_2 . The entropy of the steam is

$$n_w + x_2 n_e + k_s \log_e \frac{t}{t_s}.$$

Its behavior during expansion may be investigated by the relations previously given.

382l. Mixture of Two Vapors. Let two wet vapors at the respective conditions $w_2, p_2, t_2, x_2, h_2, l_2, r_2$, and $w_2, p_2, t_2, x_2, h_2, l_2, r_2$, be so mixed that the volume of the aggregate is $v = v_2 + v_2$. The internal energy of the mixture is

$$w_2(h_2 + x_2 r_2) + w_2(h_2 + x_2 r_2),$$

the numerical value of which may be computed for the conditions existing prior to mixing. After mixing, the temperature t being attained, the internal energy is the same as before, and the drynesses are

$$x_2' = \frac{v}{v_o' w_2'}, \quad x_2' = \frac{v}{v_o' w_2'}$$

where v_o' is the tabular volume at the temperature t . The known internal energy may then be written as a function of tabular properties at the temperature t , and the

value of t found by trial and error. The equation for adiabatic expansion entirely in the saturated field to the state t_3 is $w_2(n_w + x_2 n_e) + w_2(\mathbf{n}_w + x_2 \mathbf{n}_e) = w_2(n_w' + x_2' n_e') + w_2(\mathbf{n}_w' + x_2' \mathbf{n}_e')$, primes denoting final conditions. Thus, let 1 lb. of steam at 107 lb. pressure, 0.90 dry, be mixed with 2 lb. of carbon tetrachloride at the same pressure, 0.95 dry. The tables give $t_2 = 320$, $h_2 = 61.2$, $r_2 = 58.47$, $v_o = 0.415$, $\mathbf{n}_w = 0.1003$, $\mathbf{n}_e = 0.0855$; $t_2 = 333$, $h_2 = 303.4$, $r_2 = 802.5$, $v_o = 4.155$, $n_w = 0.4807$, $n_e = 1.1158$. Then $v_2 = 0.90 \times 4.155 = 3.75$, $v_2 = 0.95 \times 2 \times 0.415 = 0.789$, $v = 3.75 + 0.789 = 4.539$. The internal energy is

$$303.4 + (0.90 \times 802.5) + 2\{61.2 + (0.95 \times 58.47)\} = 1258 \text{ B. t. u.}$$

Since $x_2' > 1.0$ for values of t between 320° and 333° the carbon tetrachloride is superheated after mixture occurs. We must then express the energy as

$$E = h_2' + x_2' r_2' + 2 \left\{ h_2' + w_2' + \frac{k}{y} (t - t_2') \right\} = 1258,$$

in which $k = 0.056$, $y = 1.3$, $\frac{k}{y} = 0.043$, and t_2' is the saturation temperature corresponding with the partial pressure of the carbon tetrachloride. Assuming that this vapor when superheated conforms with the usual characteristic equation for gases, and putting $R = 10.0$, $p_2' = \frac{2 \times 10.0 \times t}{144 \times 4.359} = 0.0307 t$. Assuming values of t , the trial and error method gives a resulting mixture temperature close to 319° , at which $p_2' = 23.9$, $t_2' = 200^\circ$, and

$$E = 289.2 + \frac{4.539}{4.980} \cdot 814.0 + 2(34.59 + 72.64 + \overline{0.043 \times 119}) = 1255(1258) \text{ B. t. u.}$$

The entropy computed as before mixing is

$$0.481 + (0.9 \times 1.1152) + 2(0.1003 + \overline{0.95 \times 0.0855}) = 1.85;$$

after mixing, it is

$$0.4627 + \left(\frac{4.539}{4.980} \cdot 1.1492 \right) + 2 \left(0.1846 + \overline{0.056 \times 2.3 \log \frac{779}{660}} \right) = 1.89.$$

Mixing has again lowered the temperature. Let adiabatic expansion proceed until the temperature is 212° . The tetrachloride will still be superheated, and

$$0.3118 + 1.4447 x_2' + 2 \left(\mathbf{n}_w' + \mathbf{n}_e' + k \log_e \frac{672}{t_2'} \right) = 1.89.$$

For every assumed value of t_2' , the whole volume of mixture is $\frac{20 \times 672}{144 p_2'} = v'$, say: Then $x_2' = \frac{v'}{v_s'}$, where $v_s' = 26.79$, the volume of saturated steam at 212° . At

$t_2' = 106^\circ$, $p_2' = 4.37$, $v' = 21.4$, $x_2' = \frac{21.4}{26.79} = 0.798$, $n_w' + n_e' = 0.1865$; and the entropy is

$$0.3118 + 1.15 + 2(0.1865 + 0.0094) = 1.89.$$

The internal energy is now

$$180.0 + (0.798 \times 897.6) + 2(14.92 + 81.76 + \overline{0.043 + 106}) = 1098 \text{ B. t. u.},$$

and the external work done during expansion is $1258 - 1098 = 160$ B. t. u. If the two vapors had expanded from their original condition to 212° separately, the external work done would have been, very nearly, 126 B. t. u.

382i. Technical Application of Mixtures in Heat Engines. The preceding illustration shows that the expanded mixture, although at 212° F., has a pressure 4.37 lb. per sq. in. greater than that of the atmosphere. A mixture at an absolute pressure of 1 lb. (about the lowest commercially attainable) might similarly exist at a temperature considerably lower than the 102° F. which is characteristic of steam alone. A lowering of the temperature of heat-rejection is thus the feature which makes the use of a fluid mixture of practical interest. This is the more important, since from a power-producing standpoint the most fruitful part of the cyclic temperature range is the *lower* part. The operation of mixing itself reduces the initial temperature, but it in no way impairs the stock of internal energy of the constituents.

If one of the constituents is at the lower temperature of the cycle a superheated vapor, it cannot be condensed at that temperature: but since cooling water conditions permit of normal condensing temperature around 65° , the use of a mixture, even one of air and steam, may permit the attainment of that temperature without the necessity for an impracticably high vacuum.

The total heat of saturated steam increases less than $\frac{1}{3}$ B. t. u. per degree of temperature; that of superheated steam increases from 0.5 to 0.6 B. t. u. It follows that at the same temperature superheated steam "contains" more heat than saturated steam. The internal energy of saturated steam increases about 0.2 B. t. u. per degree of temperature; that of superheated steam, about 0.4 to 0.45 B. t. u. The total internal energy at a given temperature is thus also greater with superheated than with saturated steam. The less the internal energy at the end of the expansion, the greater is the amount of external work performed during expansion for given initial conditions. The analyses show that in general the effect of mixing air or vapor with steam is to decrease the dryness of the steam after expansion, and thus to decrease its final stock of internal energy and to increase the external work performed. Saturated steam expands (*i.e.*, increases in volume) more rapidly than air, as its temperature is lowered. Similarly, for a given rate of increase in volume, the temperature of air falls more rapidly than that of steam. When the two fluids are mixed, a condition of uniform temperature must prevail. This necessitates a transfer of heat from the steam to the air, decreasing the entropy of the former and increasing that of the latter. The decrease in entropy of the steam is responsible for its decreased dryness at the end of expansion.

SUPERHEATED STEAM

383. Properties: Specific Heat. In comparatively recent years, superheated steam has become of engineering importance in application to reciprocating engines and turbines and in locomotive practice.

Since superheated steam exists at a temperature exceeding that of saturation, it is important to know the specific heat for the range of superheating. The first determination was by Regnault (1862), who obtained as mean values $k = 0.4805$, $l = 0.346$, $y = 1.39$. Fenner found l to be variable, ranging from 0.341 to 0.351. Hirn, at a later date, concluded that its value must vary with the temperature. Weyrauch (29), who devoted himself to this subject from 1876 to 1904, finally concluded that the value of k increased both with the pressure and with the amount of superheating (range of temperature above saturation), basing this conclusion on his own observations as collated with those of Regnault, Hirn, Zeuner, Mallard and Le Chatelier, Sarrau and Veille, and Langen. Rankine presented a demonstration (now admitted to be fallacious) that the total heat of superheated steam was independent of the pressure. At very high temperatures, the values obtained by Mallard and Le Chatelier in 1883 have been generally accepted by metallurgists, but they do not apply at temperatures attained in power engineering. A list by Dodge (30) of nineteen experimental studies on the subject shows a fairly close agreement with Regnault's value for k at atmospheric pressure and approximately 212° F. Most experimenters have agreed that the value increases with the pressure, but the law of variation with the temperature has been in doubt. Holborn's results (31) as expressed by Kutzbach (32) would, if the empirical formula held, make k increase with the temperature up to a certain limit, and then decrease, apparently to zero.

384. Knoblauch and Jakob Experiments. These determinations (33) have attracted much attention. They were made by electrically superheating the steam and measuring the input of electrical energy, which was afterward computed in terms of its heat equivalent. These experimenters found that k increased with the pressure, and (in general) decreased with the temperature up to a certain point, afterward increasing (a result the reverse in this respect of that reported by Holborn). Figure 170 shows the results graphically. Greene (34) has used these in plotting the lines of entropy of superheat, as described in Art. 398. The Knoblauch and Jakob values are more widely used than any others experimentally obtained. They are closely confirmed by the equation derived by Goodenough (*Principles of Thermodynamics*, 1911) from fundamental analysis:

$$k = 0.367 + 0.0001T + p(1 + 0.0003p) \frac{C}{T^6},$$

where k is the true or instantaneous value of the specific heat at the constant pressure p (lbs. per sq. in.) and at the temperature T° abso-

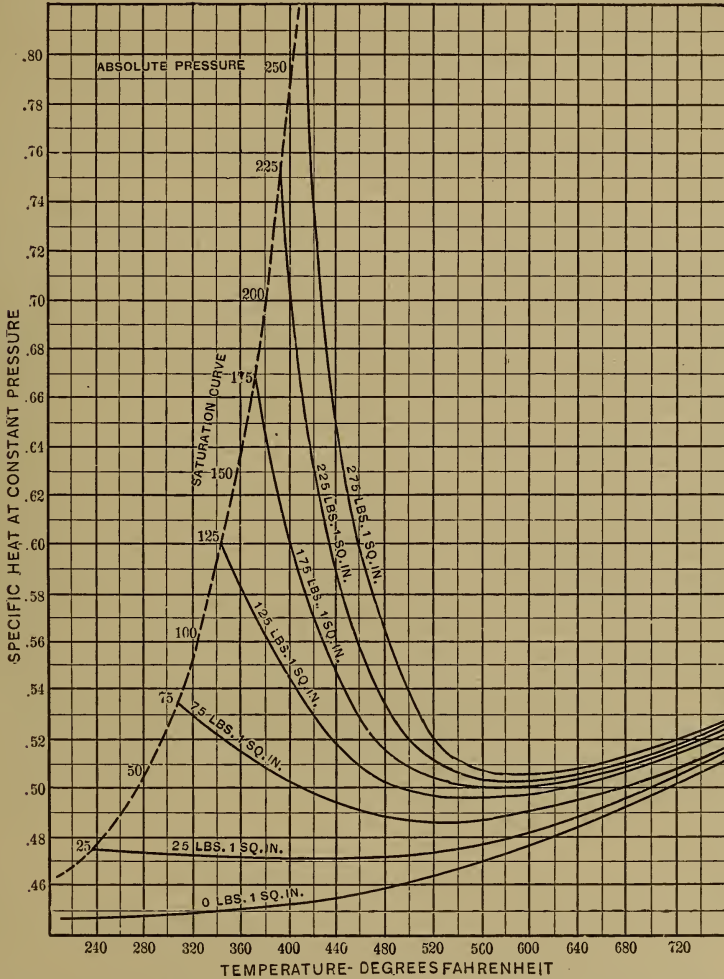

Fig. 170. Arts. 384, 421. — Specific Heat of Superheated Steam. Knoblauch and Jakob Results.

lute, and $\log C = 14.42408$. Values given by this equation should correspond with those of the curves, Fig. 170. The values in Fig. 171 are for mean specific heat at the pressure p from saturation to the temperature T , for which Goodenough's equation is

$$k_m = a + \frac{b}{2}(T + T_o) + \frac{Amp(n+1) \left(1 + \frac{a}{2}p\right) \left(\frac{1}{T_o^n} - \frac{1}{T^n}\right)}{T - T_o},$$

T_o being the saturation temperature,

$$\begin{aligned} a &= 0.367, & b &= 0.0001, & \log m &= 13.67938, \\ n &= 5, & A &= \frac{1}{7.78}, & \log \{Am(n+1)\} &= 11.566. \end{aligned}$$

385. Thomas' Experiments. In these, the electrical method of heating and a careful system of radiation corrections were employed (35). The conclusion reached was that k increases with increase of pressure and decreases with increase of temperature. The variations are greatest near the saturation curve. The values given included pressures from 7 to 500 lb.

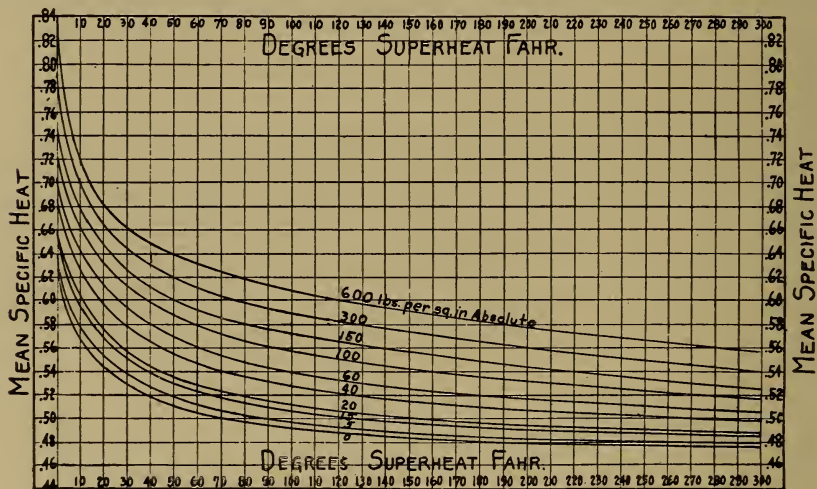

FIG. 171. Arts. 385, 388, 398, 417, Prob. 42. — Specific Heat of Superheated Steam. Thomas' Experiments.

per square inch absolute, and superheating ranging up to 270° F. The entropy lines and total heat lines are charted in Thomas' report. Within rather narrow limits, the agreement is close between these and the Knoblauch and Jakob experiments. The reasons for disagreement outside these limits have been scrutinized by Heck (36), who has presented a table of the *properties of superheated steam*, based on these and other data. The steam tables of Marks and Davis (see footnote, p. 202) contain a complete set of values for superheated states. Figure 171 shows the Thomas results graphically.

386. Total Heat. As superheated steam is almost invariably formed at constant pressure, the path of formation resembles $abcW$, Fig. 161, ab

being the water line and cd the saturation curve. Its total heat is then $H_c + k(T - t)$, where T , t refer to the temperatures at W and c . If we take Regnault's value for H_c , $1081.94 + 0.305 t$ (Art. 360), then, using $k = 0.4805$, we find the total heat of superheated steam to be $1081.94 - 0.1755 t + 0.4805 T$. A purely empirical formula, in which P is the pressure in pounds per square foot, is $H = 0.4805(T - 10.37 P^{0.25}) + 857.2$. For accurate calculations, the total heat must be obtained by using correct mean values for k during successive short intervals of temperature between t and T .

387. Variations of k . Dodge (37) has pointed out a satisfactory method for computing the law of variation of the specific heat. Steam is passed through a small orifice so as to produce a constant reduction in a constant pressure. It is superheated on both sides the orifice; but, the heat contents remaining constant during the throttling operation, the temperature changes. Let the initial pressure be p , the final pressure p_1 . Let one observation give for an initial temperature t , a final temperature t_1 ; and let a second observation give for an initial temperature T , a final temperature T_1 . Let the corresponding total heat contents be h , h_1 , H , H_1 . Then $h - H = k_p(t - T)$ and $h_1 - H_1 = k_{p_1}(t_1 - T_1)$. But $h = h_1$, $H = H_1$, whence $h - H = h_1 - H_1$ and $\frac{k_p}{k_{p_1}} = \frac{t_1 - T_1}{t - T}$. If we know the mean value of k for any given range of temperature, we may then ascertain the mean value for a series of ranges at various pressures.

388. Davis' Computation of H . The customary method of determining k has been by measuring the amount of heat necessarily added to saturated steam in order to produce an observed increase of temperature. Unfortunately, the value of H for saturated steam has not been known with satisfactory accuracy; it is therefore inadequate to measure the total heat in superheated steam for comparison with that in saturated steam at the same pressure. Davis has shown (17) that since slight errors in the value of H lead to large errors in that of k , the reverse computation—using known values of k to determine H —must be extremely accurate; so far so, that while additional determinations of the specific heat are in themselves to be desired, such determinations cannot be expected to seriously modify values of H as now computed.

The basis of the computation is, as in Art. 387, the expansion of superheated steam through a non-conducting nozzle, with reduction

of temperature. Assume, for example, that steam at 38 lb. pressure and 300° F. expands to atmospheric pressure, the temperature becoming 286° F. The total heat before throttling we may call $H_c = H_b + k_1(T_c - T_b)$, in which H_b is the total heat of *saturated* steam at 38 lb. pressure, $T_c = 300^\circ$ F., and T_b is the temperature of saturated steam at 38 lb. pressure, or 264.2° F. After throttling, similarly, $H_d = H_e + k_2(T_d - T_e)$, in which H_e is the total heat of saturated steam at atmospheric pressure, T_e is its temperature (212° F.), and T_d is 286° F. Now $H_d = H_c$, and $H_e = 1150.4$; while from Fig. 171 we find $k_1 = 0.57$ and $k_2 = 0.52$; whence

$$H_b = -0.57(300 - 264.2) + 1150.4 + 0.52(286 - 212) = 1168.47.$$

The formula given by Davis as a result of the study of various throttling experiments may be found in Art. 360. The total heat of saturated steam at some one pressure (*e.g.* atmospheric) must be known.

A simple formula (that of Smith), which expresses the Davis results with an accuracy of 1 per cent, between 70° and 500°, was given in *Power*, February 8, 1910.

It is
$$H = 1826 + t - \frac{1,250,000}{1620 - t},$$

t being the Fahrenheit temperature.

389. Factor of Evaporation. The computation of factors of evaporation must often include the effect of superheat. The total heat of superheated steam—which we may call H_s —may be obtained by one of the methods described in Art. 386. If h_0 is the heat in the water as supplied, the heat expended is $H_s - h_0$ and the factor of evaporation is

$$(H_s - h_0) \div 970.4.$$

390. Characteristic Equation. Zeuner derives as a working formula, agreeing with Hirn's experiments on specific volume (38),

$$PV = 0.64901 T - 22.5819 P^{0.25},$$

in which P is in pounds per square inch, V in cubic feet per pound, and T in degrees absolute Fahrenheit. This applies closely to saturated as well as to superheated steam, *if dry*. Using the same notation, Tumlriz gives (39) from Battelli's experiments,

$$PV = 0.594 T - 0.00178 P.$$

The formulas of Knoblauch, Linde and Jakob, and of Goodenough, both given in Art. 363, may also be applied to superheated steam, if not too

the form $PV^n = \text{constant}$, if the value of n were made to depend upon the initial dryness. He represented this by

$$n = 1.035 + 0.100 X,$$

for values of X ranging from 0.70 to 1.00, and found it to lead to sufficiently accurate results for all usual expansions. For a **compression** from an initial dryness x , $n = 1.034 + 0.11 x$. Where the steam is initially dry, $n = 1.135$ for expansion and 1.144 for compression. There is seldom any good reason for the use of exponential formulas for steam adiabatics. The relation between the true adiabatic and that described by the exponential equation is shown by the curves of Fig. 173, after

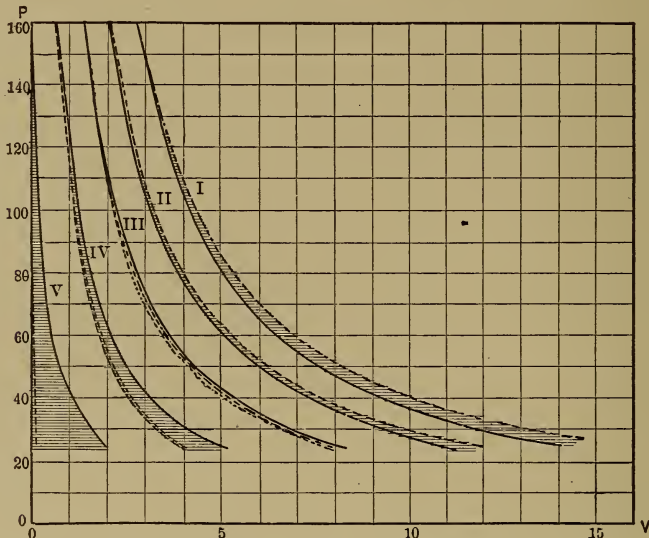

FIG. 173. Arts. 394, 395. — Adiabatic and Saturation Curves.

Heck (40). In each of these five sets of curves, the solid line represents the adiabatic, while the short-dotted lines are plotted from Zeuner's equation, and the long-dotted lines represent the constant dryness curves. In I and II, the two adiabatics apparently exactly coincide, the values of x being 1.00 and 0.75. In III, IV, and V, there is an increasing divergence, for $x = 0.50, 0.25$ and 0. Case V is for the liquid, to which no such formula as those discussed could be expected to apply.

395. Adiabatics and Constant Dryness Curves. The constant dryness curves I and II in Fig. 173 fall above the adiabatic, indicating that *heat is absorbed during expansion along the constant dryness line*. Since the temperature falls during expansion, the specific heat along these constant dryness curves, within the limits shown, must necessarily be negative, a result otherwise derived in Art. 373. The points of tangency of these curves with the corresponding adiabatics give the points of inversion, at which the specific heat changes sign.

396. External Work. The work during adiabatic expansion from PV to pv , assuming $pv^n = PV^n$, is represented by the formula

$$\frac{PV - pv}{n - 1}.$$

More accurately, remembering that the work done equals the loss of internal energy, we find its value to be $H - h + XR - xr$, in which H and h denote the initial and final *heats of the liquid*.

397. Superheated Adiabatic. Three cases are suggested in Fig. 174, paths jm , jk , de , the initially superheated vapor being either dry, wet, or superheated at the

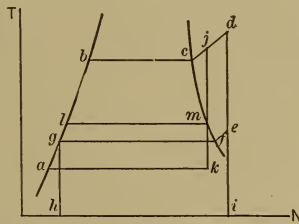

FIG. 174. Art. 397. — Steam Adiabatics.

end of expansion. If k be the mean value of the specific heat of superheated steam for the range of temperatures in each case, then

$$\text{for } jm, c \log_e \frac{T_b}{T_i} + \frac{L_c}{T_b} + k \log_e \frac{T_j}{T_b} = \frac{L_m}{T_i};$$

$$\text{for } jk, c \log_e \frac{T_b}{T_a} + \frac{L_c}{T_b} + k \log_e \frac{T_j}{T_b} = \frac{x_k L_k}{T_a};$$

$$\text{for } de, c \log_e \frac{T_b}{T_g} + \frac{L_c}{T_b} + k_1 \log_e \frac{T_d}{T_b} = \frac{L_f}{T_g} + k_2 \log_e \frac{T_e}{T_f}.$$

398. Entropy Lines for Superheat. Many problems in superheated steam are conveniently solved by the use of a carefully plotted entropy diagram, as shown in Fig. 175.* The plotting of the curves within the saturated limits has already been explained. At the upper right-hand corner of the diagram there appear constant pressure lines and constant total heat curves. The former may be plotted when we know the mean specific heat k at a stated pressure between the temperatures T and t : the entropy gained being $k \log_e \frac{T}{t}$. The lines of total heat are determined

* This diagram is based on saturated steam tables embodying Regnault's results, and on Thomas' values for k ; it does not agree with the tables given on pages 247, 248. The same remark applies to Figs. 159 and 177.

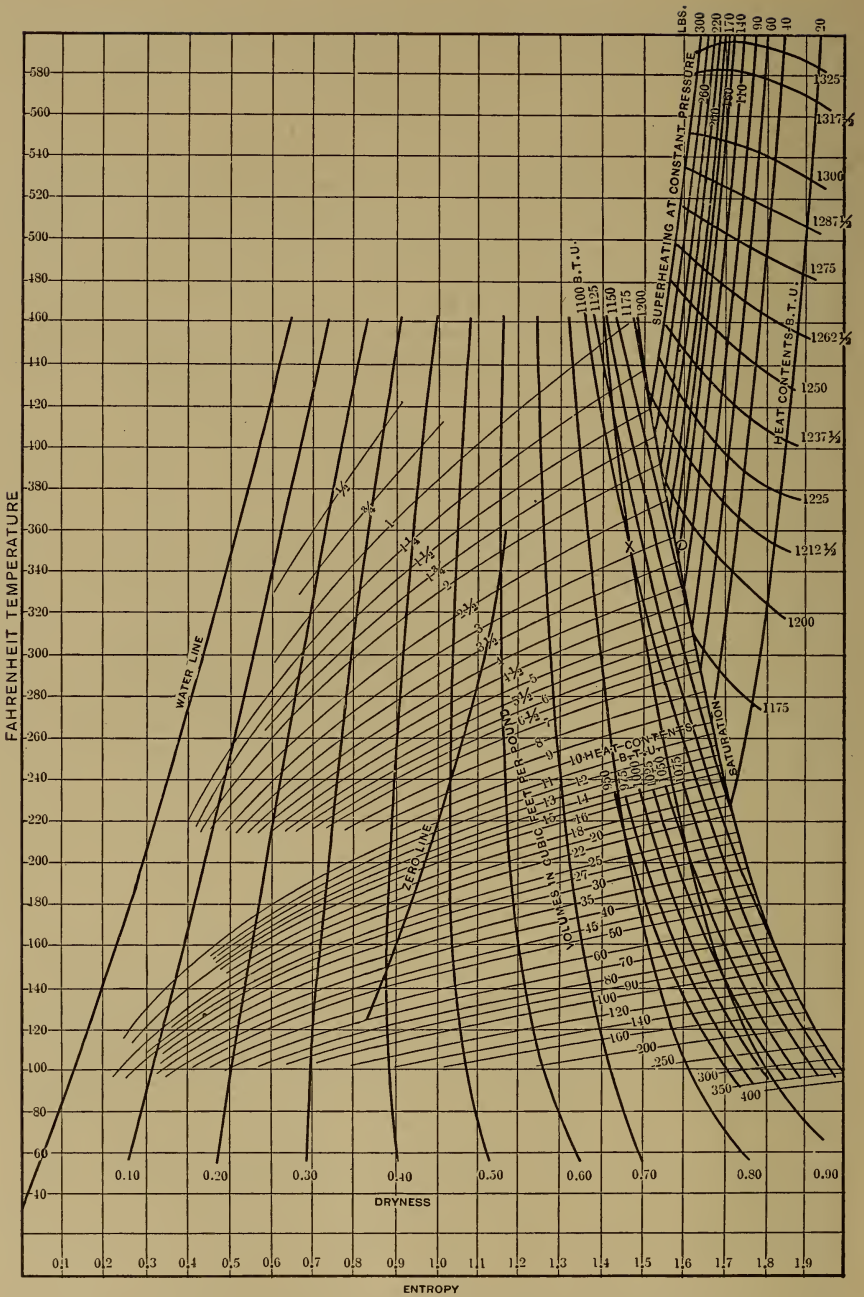

FIG. 175. Arts. 377, 398, 401, 411, 417, 516, Problems.—Temperature-entropy Chart for Steam.

by the following method:—For saturated steam at 103.38 lb. pressure, $H = 1182.6$, $T = 330^\circ \text{ F}$. As an approximation, the total heat of 1200 B. t. u. will require $(1200 - 1182.6) \div 0.4805 = 36.1^\circ \text{ F}$. of superheating. For this amount of superheating at 100 lb. pressure, the mean specific heat is, according to Thomas (Fig. 171), 0.604; whence the rise in temperature is $17.4 \div 0.604 = 28.7^\circ \text{ F}$. For this range (second approximation), the mean specific heat is 0.612, whence the actual rise of temperature is $17.4 \div 0.612 = 28.4^\circ \text{ F}$. No further approximation is necessary; the amount of superheating at 1200 B. t. u. total heat may be taken as 28° F ,

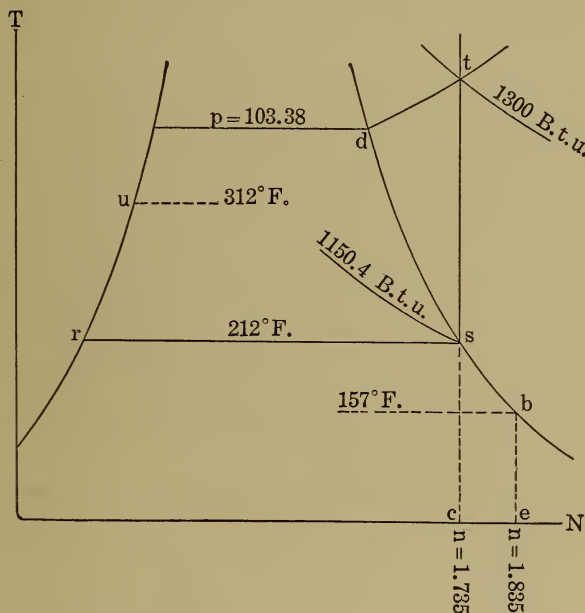

FIG. 176. Arts. 398, 399, 401.—Entropy Diagram, Superheated Steam.

which is laid off vertically from the point where the saturation curve crosses the line of 330° F ., giving one point on the 1200 B. t. u. total heat curve.

A few examples in the application of the chart suggest themselves. Assume steam to be formed at 103.38 lb. pressure; required the necessary amount of superheat to be imparted such that the steam shall be just dry after adiabatic expansion to atmospheric pressure. Let rs , Fig. 176, be the

line of atmospheric pressure. Draw st vertically, intersecting d ; then t is the required initial condition. Along the adiabatic ts , the heat contents decrease from 1300 B. t. u. to 1150.4 B. t. u., a loss of 149.6 B. t. u.

To find the condition of a mixture of unequal weights of water and superheated steam after the establishment of thermal equilibrium, the whole operation being conducted at constant pressure: let the water, amounting to 10 lb., be at r , Fig. 176. Its heat contents are 1800 B. t. u. Let one pound of steam be at t , having the heat contents 1300 B. t. u. The heat gained by the water must equal that lost by the steam; the final heat contents will then be 3100 B. t. u., or 282 B. t. u. per pound, and the state

will be u , where the temperature is 312°F. ; the steam will have been completely liquefied.

We may find, from the chart, the total heat in steam (wet, dry, or superheated) at any temperature, the quality and heat contents after adiabatic expansion from any initial to any final state, and the specific volume of saturated steam at any temperature and dryness.

399. The Mollier Heat Chart. This is a variant on the temperature entropy diagram, in a form rather more convenient for some purposes. It has been developed by Thomas (41) to cover his experiments in the superheated region, as in Fig. 177. In this diagram, the vertical coördinate is entropy; and the horizontal, total heat. The constant heat lines are thus vertical, while adiabatics are horizontal. The saturation curve is inclined upward to the right, and is concave toward the left. Lines of constant pressure are nearly continuous through the saturated and superheated regions. The quality lines follow the curvature of the saturation line. The temperature lines in the superheated region are almost vertical. It should be remembered that the "total heat" thus used as a coördinate is nevertheless not a cardinal property. The "total heat" at t , Fig. 176, for example, is that quantity of heat which would have been imparted had water at 32°F. been converted into superheated steam at *constant pressure*.

It will be noted that within the portion of saturated field which is shown, the total heat at a given pressure is directly proportional to the total entropy. This would be *exactly* true if the water line in Fig. 175

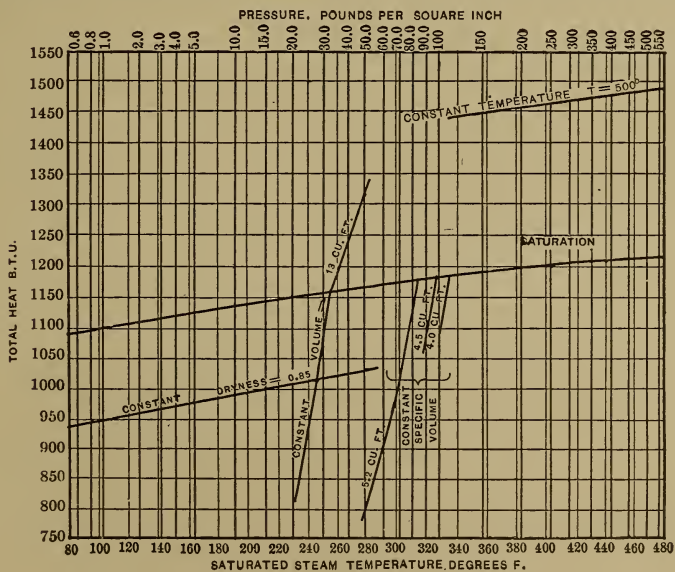

Fig. 185. Art. 399, Problems. — Total Heat-pressure Diagram,

were a straight line and if at the same time the specific heat of water could be constant. An empirical equation might be written in the form

$$n_s = aH \times (f) \frac{1}{P},$$

where n_s , H and P are the total entropy, total heat and pressure of a wet vapor.

The so-called *total heat-pressure* diagram (Fig. 185) is a diagram in which the coördinates are *total heat* above 32° F. and *saturation temperature*; it usually includes curves of (a) constant volume, (b) constant dryness, and (c) in the superheated field, constant temperature. Vertical lines show the loss or gain of heat corresponding to stated changes of volume or quality at constant pressure. Horizontal lines show the change in pressure, volume, and quality of steam resulting from throttling (Art. 387). This diagram is a useful supplement to that of Mollier.

Heck has developed a *pressure-temperature* diagram for both saturated and superheated fields, on which curves of constant entropy and constant total heat (throttling curves) are drawn. By transfer from these, there is derived a new diagram of *total heat on pressure*, on which are shown the isothermals of superheat. A study of the shape of these isothermals illustrates the variations in the specific heat of superheated steam.

VAPORS IN GENERAL

400. Analytical Method: Mathematical Thermodynamics. An expression for the volume of any saturated vapor was derived in Art. 368:

$$W = V + 778 \frac{L}{T} \frac{dT}{dP}.$$

Where the specific volume is known by experiment, this equation may be used for computing the latent heat. A general method of deriving this and certain related expressions is now to be described. Let a mixture of x lb. of dry vapor with $(1-x)$ lb. of liquid receive heat, dQ . Then

$$dQ = kxdT + c(1-x)dT + Ldx,$$

in which k is the "specific heat" of the continually dry vapor, L the latent heat of evaporation, and c the specific heat of the liquid. If P, V are the pressure and volume, and E the internal energy, in foot-pounds, of the mixture, then

$$dQ = \frac{PdV + dE}{778} = kxdT + c(1-x)dT + Ldx, \text{ whence}$$

$$dE = 778 [kx + c(1-x)]dT + 778 Ldx - PdV.$$

Now $V = (f)T, x$; whence $dV = \frac{\delta V}{\delta T}dT + \frac{\delta V}{\delta x}dx$, whence

$$\begin{aligned} dE &= 778 [kx + c(1-x)]dT + 778 Ldx - P \frac{\delta V}{\delta T}dT - P \frac{\delta V}{\delta x}dx \\ &= \left\{ 778 [kx + c(1-x)] - P \frac{\delta V}{\delta T} \right\} dT + \left(778 L - P \frac{\delta V}{\delta x} \right) dx. \end{aligned}$$

Moreover, $E = (f)T, x$, whence

$$\frac{\delta}{\delta x} \left(\frac{\delta E}{\delta T} \right) = \frac{\delta}{\delta T} \left(\frac{\delta E}{\delta x} \right),$$

$$\text{giving } \frac{\delta}{\delta T} \left(778 L - P \frac{\delta V}{\delta x} \right) = \frac{\delta}{\delta x} \left\{ 778 [kx + c(1-x)] - P \frac{\delta V}{\delta T} \right\}$$

$$\text{or, } 778 \frac{\delta L}{\delta T} - \frac{dP \delta V}{dT \delta x} - P \frac{\delta^2 V}{\delta x \delta T} = 778 (k - c) - P \frac{\delta^2 V}{\delta T \delta x}, \tag{A}$$

(all properties excepting V and x being functions of T only).

The volume, V , may be written $xu + v$, where v is the volume of the liquid and u the increase of volume during vaporization. This gives $\delta V = u \delta x$ or $\frac{\delta V}{\delta x} = u$.

Also, since $V = (f) T$, x , $\frac{\delta^2 V}{\delta T \delta x} = \frac{\delta^2 V}{\delta x \delta T}$, and equation (A) becomes

$$778 \frac{dL}{dT} - \frac{dP \delta V}{dT \delta x} = 778 (k - c), \text{ or } 778 \frac{dL}{dT} + 778 (c - k) = u \frac{dP}{dT}, \text{ or}$$

$$\frac{dL}{dT} + c - k = \frac{u}{778} \frac{dP}{dT}. \tag{B}$$

Now if the heat is absorbed along any reversible path, $\frac{dQ}{dT} = dN$, or

$$dN = \frac{kx dT + c(1-x)dT + L dx}{T} = \frac{kx + c(1-x)}{T} dT + \frac{L}{T} dx.$$

But $N = (f)x, T$, whence, $\frac{\delta}{\delta x} \left(\frac{\delta N}{\delta T} \right) = \frac{\delta}{\delta T} \left(\frac{\delta N}{\delta x} \right)$,

$$\frac{\delta}{\delta x} \frac{kx + c(1-x)}{T} = \frac{\delta}{\delta T} \frac{L}{T},$$

$$\frac{k - c}{T} = \frac{T \frac{dL}{dT} - L}{T^2},$$

$$\frac{dL}{dT} + c - k = \frac{L}{T}, \tag{C}$$

which may be combined with (B), giving

$$778 \frac{L}{T} \frac{dT}{dP} = u = V - v, \text{ as in Art. 369.} \tag{D}$$

401. Computation of Properties. Equation (D), as thus derived, or as obtained in Art. 369, may be used to compute either the *latent heat* or the *volume* of any vapor when the other of these properties and the relation of temperature and pressure is known. The *specific heat of the saturated vapor* may be obtained from (C); the *temperature of inversion* is reached when the specific heat changes sign. For steam, if $L = 1113.94 - 0.695t$ (Art. 379), where t is in degrees F., or $1113.94 - 0.695(T - 459.6)$ where T is the absolute temperature: $\frac{dL}{dT} = -0.695$.

Also $c = 1$; whence, from equation (C), $k = 0.305 - \frac{L}{T}$, which equals zero when $T = 1433^\circ$ absolute.* At 212° F., $k = 0.305 - \frac{970.4}{671.6} = -1.135$. This may be roughly

* This would be the temperature of inversion of dry steam if the formula for L held: but L becomes zero at 689° F. (Art. 379), and the saturation curve for steam slopes downward toward the right throughout its entire extent. For the dry vapors of chloroform and benzene, there exist known temperatures of inversion.

checked from Fig. 175. In Fig. 176, consider the path sb from 212° F. to 157° F., and from $n = 1.735$ to $n = 1.835$ (Fig. 175). The average height of the area $csbe$ representing the heat absorbed is $459.6 + \frac{212 + 157}{2} = 644.1$; whence, the area is $644.1(1.835 - 1.735) = 64.41$ B. t. u., and the mean specific heat between s and b is $64.41 \div (212 - 157) = 1.176$. The properties of the volatile vapors used in refrigeration are to some extent known only by computations of this sort. When once the pressure-temperature relation and the characteristic equation are ascertained by experiment, the other properties follow.

402. Engineering Vapors. The properties of the vapors of steam, carbon dioxide, ammonia, sulphur dioxide, ether, alcohol, acetone, carbon disulphide, carbon tetrachloride, and chloroform have all been more or less thoroughly studied. The first five are of considerable importance. For *ether, alcohol, chloroform, carbon disulphide, carbon tetrachloride, and acetone*, Zeuner has tabulated the pressure, temperature, volume, total heat, latent heat, heat of the liquid, and internal and external work of vaporization, in both French and English units (42), on the basis of Regnault's experiments. The properties of these substances as given in Peabody's "Steam Tables" (1890) are reproduced from Zeuner, excepting that the values -273.7 and 426.7 are used instead of -273.0 and 424.0 for the location of the absolute zero centigrade and the centigrade mechanical equivalent of heat, respectively. Peabody's tables for these vapors are in French units only. Wood has derived expressions for the properties of these six vapors, but has not tabulated their values (43). Rankine (44) has tabulated the pressure, latent heat, and density of *ether*, per cubic foot, in English units, from Regnault's data. For *carbon dioxide*, the experimental results of Andrews, Cailletet and Hautefeuille, Cailletet and Mathias (45), and, finally, Amagat (46), have been collated by Mollier, whose table (47) of the properties of this vapor has been reproduced and extended, in French and English units, by Zeuner (48). The vapor tables appended to Chapter XVIII, it will be noted, are based on those of Zeuner. The entropy diagrams for ammonia, ether, and carbon dioxide, Figs. 314-316, have the same foundation.

The present writer (in *Vapors for Heat Engines*, D. Van Nostrand Co., 1911) has computed the entropies and prepared temperature-entropy diagrams for alcohol, acetone, chloroform, carbon chloride and carbon disulphide.

403. Ammonia. Anhydrous ammonia, largely used in refrigerating machines, was first studied by Regnault, who obtained the relation

$$\log p = 8.4079 - \frac{2196}{t},$$

in which p is in pounds per square foot and t is the absolute temperature. A "characteristic equation" between p , v , and t was derived by Ledoux (49) and employed by Zeuner to permit of the computation of V , L , e , r and the specific heat of the liquid (the last having recently been determined experimentally (50)). The results thus derived were tabulated by Zeuner (51) for temperatures below 32° F.; while for higher temperatures he uses the experimental values of Dietrici (52). Peabody's table (53), also derived from Ledoux, uses his values for temperatures exceeding 32° F.; Zeuner regards Ledoux's values in this region as unreliable.

Peabody's table is in French units; Zeuner's is in both French and English units. The latent heat of evaporation has been experimentally determined by Regnault (54) and Von Strombeck (55). The specific volume of the vapor at -26.4° F. and atmospheric pressure is 17.51 cu. ft.; that of the liquid is 0.025; whence from equation (D), Art. 400,

$$L = \frac{T}{778}(V-v)\frac{dP}{dT}$$

$$= \frac{433.2}{778}(17.51 - 0.025)\left(\frac{2196 \times 2.3026 \times 14.7 \times 144}{433.2 \times 433.2}\right) = 555,$$

the value of $\frac{dP}{dT}$ being obtained by differentiating Regnault's equation, above given. From a study of Regnault's experiments, Wood has derived the characteristic equation,

$$\frac{PV}{T} = 91 - \frac{16920}{TV^{0.97}},$$

which is the basis of his table of the properties of ammonia vapor (56). Wood's table agrees quite closely with Zeuner's, as to the relation between pressure and temperature; but his value of L is much less variable. For temperatures below 0° C., the specific volumes given by Wood are rather less than those by Zeuner; for higher temperatures, the volumes vary less. Zeuner's table must be regarded as probably more reliable. The specific heat (0.508) and the density (0.597, when air = 1.0) of the superheated vapor have been determined by experiment.

404. Sulphur Dioxide. The specific heat of the superheated vapor is given by Regnault as 0.15438 (57). The specific volume, as compared with that of air, is 2.23 (58). The specific volume of the liquid is 0.0007 (59); its specific heat is approximately 0.4. A characteristic equation for the saturated vapor has been derived from Regnault's experiments:

$$PV = 26.4 T - 184 P^{0.22};$$

in which P is in pounds per square foot, V in cubic feet per pound, and T in absolute degrees. The relation between pressure and temperature has been studied by Regnault, Sajotschewski, Blumcke, and Miller. Regnault's observations were made between -40° and 149° F.; Miller's, between 68 and 211° F.; a table representing the combined results has been given by Miller (60). In the usual form of the general equation,

$$\log p = a - bd^n - ce^n,$$

the values given by Peabody for pressures in pounds per square inch are (61) $a = 3.9527847$, $\log b = 0.4792425$, $\log d = 1.9984994$, $\log c = 1.1659562$, $\log e = 1.99293890$, $n = 18.4 +$ Fahrenheit temperature. The specific volumes, determined by the characteristic equation and the pressure-temperature formula, permit of the computation of the latent heat from equation (D), Art. 400. An empirical formula

for this property is $L = 176 - 0.27(t - 32)$, in which t is the Fahrenheit temperature. The experimental results of Cailletet and Mathias, and of Mathias alone (62), have led to the tables of Zeuner (63). Peabody, following Ledoux's analysis, has also tabulated the properties in French units. Wood (64) has independently computed the properties in both French and English units. Comparing Wood's, Zeuner's, and Peabody's tables, Zeuner's values for L and V are both less than those of Peabody. At 0° F., he makes L less than does Wood, departing even more widely than the latter from Jacobus' experimental results (65); at 30° F., his value of L is greater than Wood's, and at 104° F., it is again less. The tabulated values of the specific volumes differ correspondingly. Zeuner's table may be regarded as sustained by the experiments of Cailletet and Mathias, but the lack of concordance with the experimental results of Jacobus remains to be explained.

405. Steam at Low Temperatures. Ordinary tables do not give the properties of water vapor for temperatures lower than those corresponding to the absolute pressures reached in steam engineering. Zeuner has, however, tabulated them for temperatures down to -4° F. (66).

405a. Vapors for Heat Engines. Engines have been built using, instead of steam, the vapors of alcohol, gasolene, ammonia, ether, sulphur dioxide and carbon dioxide, with good results as to thermal efficiency, if not with commercial success. In a simple condensing engine, with a rather low expansive ratio, a considerable saving may be effected with some of these vapors, as compared with steam; and the cost of the fluid is not a vital matter, since it may be used over and over again. Strangely enough, in the case of none of the vapors is a very low discharge temperature practically desirable, under usual simple condensing engine conditions. This statement applies even to steam. The Carnot criterion $\frac{T-t}{T}$ does not exactly apply, since it refers to potential efficiency only: but the use of a substitute vapor might perhaps be justified on one of the two grounds, (a) an increased upper temperature without excessive pressures or (b) a decreased lower temperature at a reasonable vacuum, say of 1 lb. absolute. To meet both requirements the vapor would have to give a pt curve *crossing that of steam*. It is probable that carbon tetrachloride is such a vapor, bearing such a relation to steam as alcohol does to it. No great gain is possible in respect to the lower temperature limit, since this limit is in any case established by the cooling water. The criterion given in Art. 630 measures the relative efficiencies of fluids working in the Clausius cycle. On this basis steam surpasses all other common vapors in potential thermal efficiency.

The lower "heat content" per pound of the more volatile and heavy vapors leads to a greatly reduced nozzle velocity with adiabatic flow, and this suggests the possibility of developing a turbine expanding in one operation without excessive peripheral speeds (see Chapter XIV).

The greater density of the volatile vapors also leads to the conclusion that the output from a cylinder of given size might in the cases of some of them be about twice what it is from a steam cylinder.

On the whole, the use of a special vapor seems to be more promising, technically and commercially, than the binary vapor principle (Art. 483). For a fuller discussion of this subject, reference may be made to the work referred to in Art. 402.

STEAM CYCLES

406. The Carnot Cycle for Steam. This is shown in Figs. 163, 179. The efficiency of the cycle *abcd* may be read from the entropy

diagram as $\frac{T-t}{T}$. The external

work done per pound of steam

is $L\frac{T-t}{T}$; or if the steam at *b*

is wet, it is $xL\frac{T-t}{T}$. If the

fluid at the beginning of the

cycle (point *a*) is wet steam

instead of water, the dryness

being x_0 , then the work per

pound of steam is $L(x - x_0)$

$\frac{T-t}{T}$. In the cycle first discussed, in order that the final adiabatic

compression may bring the substance back to its initially dry state at

a, such compression must begin

at *d*, where the dryness is $md \div mn$.

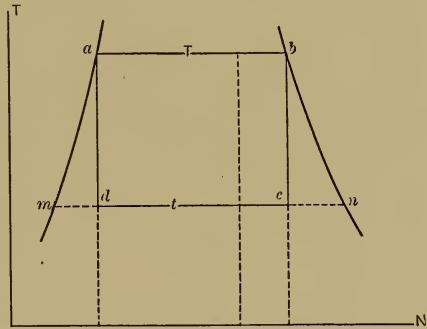

FIG. 179. Art. 406.—Carnot Cycle for Steam.

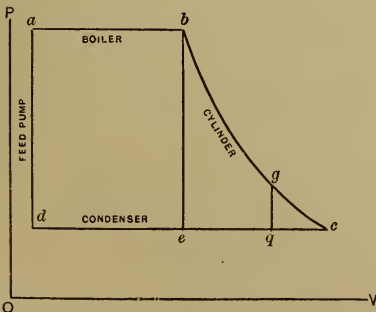

FIG. 180. Arts. 407, 408, 410, 412, 413.—The Steam Power Plant.

The Carnot cycle is impracticable with steam; the substance at *d* is mostly liquid, and cannot be raised in temperature by compression. What is actually done is to allow condensation along *cd* to be completed, and then to warm the liquid or its equivalent along *ma* by transmission of heat from an external source. This, of course, lowers the efficiency.

407. The Steam Power Plant. The cycle is then *not completed* in the *cylinder* of the engine. In Fig. 180, let the substance at *d* be

cold water, either that resulting from the action of the condenser on the fluid which has passed through the engine, or an external supply. This water is now delivered by the **feed pump** to the **boiler**, in which its temperature and pressure become those along *ab*. The work done by the feed pump per pound of fluid is that of raising unit weight of the liquid against a head equivalent to the pressure; or, what is the same thing, the product of the specific volume of the water by the range in pressure, in pounds per square foot. From *a* to *b* the substance is in the **boiler**, being changed from water to steam. Along *bc*, it is expanding in the **cylinder**; along *cd* it is being liquefied in the **condenser** or being discharged to the atmosphere. In the former case, the resulting liquid reaches the feed pump at *d*. In the latter, a fresh supply of liquid is taken in at *d*, but this may be thermally equivalent to the liquid resulting from atmospheric exhaust along *cd*. (See footnote, Art. 502.) The four

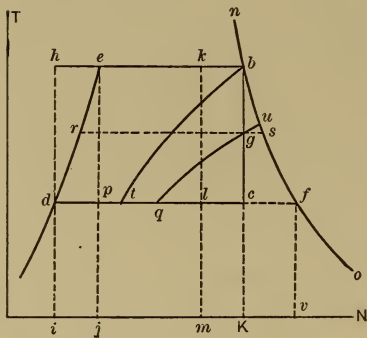

FIG. 181. Arts. 408-413. — Steam Cycles.

organs, feed pump, boiler, cylinder, and condenser, are those essential in a steam power plant. The cycle represents the changes undergone by the fluid in its passage through them.

408. Clausius Cycle. The cycle of Fig. 180, worked *without adiabatic compression*, is known as that of *Clausius*. Its entropy diagram is shown as *debc* in Fig. 181, that of the corresponding Carnot cycle being *dhbc*. The Carnot efficiency is obviously greater than that of the Clausius cycle. For wet steam the corresponding cycles are *dekl* and *dhkl*.

409. Efficiency. In Fig. 181, cycle *debc*, the efficiency is

$$\frac{debc}{idebK} = \frac{idej + jebK - idcK}{idej + jebK} = \frac{h_e - h_d + L_b - x_c L_f}{h_e - h_d + L_b}$$

But $x_c = dc + df = \frac{dp + eb}{df} = \frac{\log_e \frac{T_e}{T_d} + \frac{L_b}{T_e}}{L_f \div T_d}$, if the specific heat of the

liquid be unity. Then letting T, L refer to the state b , and t, l to the state c , the efficiency is

$$\frac{T - t + L - t \log_e \frac{T}{t} - t \frac{L}{T}}{T - t + L} = \frac{(T - t) \left(1 + \frac{L}{T}\right) - t \log_e \frac{T}{t}}{T - t + L},$$

which is determined *solely by the temperature limits* T and t . For steam initially wet, the efficiency is

$$\frac{(T - t) \left(1 + \frac{XL}{T}\right) - t \log_e \frac{T}{t}}{T - t + XL}.$$

410. Work Area. In Figs. 180, 181, we have

$$\begin{aligned} W &= W_{ab} + W_{bc} - W_{cd} - W_{da} \\ &= [p_b(v_b - v_a)] + (h_e + r_b - h_d - x_c r_f) - [p_c x_c (v_f - v_d)] - 0, \end{aligned}$$

ignoring the small amount of work done by the feed pump in forcing the liquid into the boiler. But $p_b(v_b - v_a) = e_b$ and $p_c x_c (v_f - v_d) = x_c e_f$ (Art. 359), whence

$$W = h_e + L_b - h_d - x_c L_f,$$

a result identical with the numerator of the first expression in Art. 409.

411. Rankine Cycle. The cycle $debgq$, Fig. 181, $abgqd$, Fig. 180, is known as that of Rankine (67). It differs from that of Clausius merely in that expansion is incomplete, the "toe" gcq , Fig. 180, being cut off by the limiting cylinder volume line gq . This is the ideal cycle nearest which actual steam engines work. The line gq in Fig. 181 is plotted as a line of constant volume (Art. 377). The efficiency is obviously less than that of the Clausius cycle; it is

$$\begin{aligned} \frac{ebgqd}{idebK} &= \frac{W_{ab} + W_{bg} - W_{gd} \text{ (Fig. 180)}}{h_e - h_d + L_b} \\ &= \frac{[p_b(v_b - v_a)] + (h_e + r_b - h_r - x_g r_s) - [p_g x_g (v_f - v_d)]}{h_e - h_d + L_b}. \end{aligned}$$

The values of h_r, x_g, r_s, x_g , depend upon the limiting volume $v_g = v_r$, and may be most readily ascertained by inspecting Fig. 175. The *computation* of these properties resolves itself into the problem: *given*

the initial state, to find the temperature after adiabatic expansion to a given volume. We have

$$v_g - v_r = x_g(v_s - v_r), \quad n_g = n_b,$$

$$x_g = \frac{n_g - n_r}{n_s - n_r} = \frac{n_b - n_r}{n_s - n_r} = \frac{\log_e \frac{T_c}{T_r} + \frac{L_b}{T_e}}{L_s \div T_r},$$

whence

$$v_g = v_r + \frac{T_r \left(\log_e \frac{T_c}{T_r} + \frac{L_b}{T_e} \right)}{L_s} (v_s - v_r),$$

in which v_g , T_e , L_b are given, $v_r = 0.017$, and v_s , L_s are functions of T_r , the value of which is to be ascertained. The greater the ratio of expansion, $v_g \div v_b$, Fig. 181, with given cyclic limits, the greater is the efficiency.

412. Non-expansive Cycle. This appears as *debt*, Fig. 181; and *abcd*, Fig. 180. No expansion occurs; work is done only as steam is evaporated or condensed. The efficiency is (Fig. 181)

$$\frac{debt}{idebK} = \frac{W_{ab} - W_{ed} \text{ (Fig. 180)}}{h_e - h_d + L_b} = \frac{p_b(v_b - v_a) - p_t(v_b - v_d)}{h_e - h_d + L_b}.$$

This is the least efficient of the cycles considered.

413. Pambour Cycle. The cycle *defb*, Fig. 181, represents the operation of a plant in which the steam *remains dry* throughout expansion. It is called the *Pambour cycle*. Expansion may be incomplete, giving such a diagram as *debuq*. Let *abcd* in Fig. 180 represent *defb* in Fig. 181. The efficiency is

$$\begin{aligned} \frac{\text{external work done}}{\text{gross heat absorbed}} &= \frac{\text{external work done}}{\text{heat rejected} + \text{external work done}} \\ &= \frac{W_{ab} + W_{bc} - W_{cd}}{L_f + W_{ab} + W_{bc} - W_{cd}} = \frac{p_b(v_b - v_a) + 16(p_b v_b - p_f v_f) - p_f(v_f - v_d)}{L_f + p_b(v_b - v_a) + 16(p_b v_b - p_f v_f) - p_f(v_f - v_d)}, \end{aligned}$$

in which the saturation curve *bf* may be represented by the formula $pv^{1.6} = \text{constant}$ (Art. 363). A second method for computing the efficiency is as follows: the area $debf = \int_t^T \frac{L}{T} dT$, in which T and t are the temperatures along *eb* and *df* respectively, and $L = (f)T = 1433 - 0.695 T$ (Art. 379). This gives

$$debf = 1433 \log_e \frac{T}{t} - 0.695(T - t),$$

and the efficiency is

$$\frac{debf}{idebfv} = \frac{debf}{debf + idfc} = \frac{1433 \log_e \frac{T}{t} - 0.695(T - t)}{1433 \log_e \frac{T}{t} - 0.695(T - t) + L_f}.$$

The two computations will not precisely agree, because the exponent $\frac{1}{2}$ does not exactly represent the saturation curve, nor does the formula for L in terms of T hold rigorously.

Of the whole amount of heat supplied, the portion $Kbfv$ was added during expansion, as by a steam jacket (Art. 439). To ascertain this amount, we have

heat added by jacket

$$= \text{whole heat supplied} - \text{heat present at beginning of expansion}$$

$$= 1433 \log_e \frac{T}{t} - 0.695(T-t) + L_r - h_e + h_a - L_b.$$

The efficiency is apparently less than that of the Clausius cycle (Fig. 181). In practice, however, steam jacketing increases the efficiency of engines, for reasons which will appear (Art. 439).

414. Cycles with Superheat. As in Art. 397, three cases are possible. Figure 182 shows the Clausius cycles $debxw$, $debyf$, $debzAf$, in which the steam is respectively wet, dry, and superheated at the end of expansion. To appreciate the gain in efficiency due to superheat, compare the first of these cycles, not with the dry steam Clausius cycle $debc$, but with the superior Carnot cycle $dhbc$. If the path of superheating were bC , the efficiency would be unchanged; the actual path is bx , and the work area bxC is gained at 100 per cent efficiency. The cycle $dhbxw$ is thus more efficient than the Carnot cycle $dhbc$, and the cycle $debxw$ is more efficient than the Clausius cycle $debc$. It is not more efficient than a Carnot cycle through its own temperature limits.

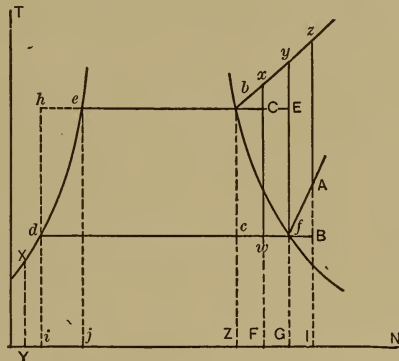

FIG 182. Art. 414. — Cycles with Superheat.

The cycle $debyf$ shows a further gain in efficiency, the work area added at 100 per cent effectiveness being byE . The cycle $debzAf$ shows a still greater addition of this desirable work area, but a loss of area AfB now appears. Maximum efficiency appears to be secured with such a cycle as the second of those considered, in which the steam is about dry at the end of expansion. The Carnot formula

The cycle $debyf$ shows a further gain in efficiency, the work area added at 100 per cent effectiveness being byE . The cycle $debzAf$ shows a still greater addition of this desirable work area, but a loss of area AfB now appears. Maximum efficiency appears to be secured with such a cycle as the second of those considered, in which the steam is about dry at the end of expansion. The Carnot formula

suggests the desirability of a high upper temperature, and superheating leads to this; but when superheating is carried so far as to appreciably raise the *temperature of heat emission*, as in the cycle $debzAf$, the efficiency begins to fall.

415. Efficiencies. The work areas of the three cycles discussed may be thus expressed:

$$\begin{aligned} W_{debxw} &= H_{debxw} = H_{de} + H_{eb} + H_{bx} - H_{wd} \\ &= h_e - h_d + L_b + k_1(T_x - T_b) - x_w L_f; \end{aligned}$$

$$\begin{aligned} W_{debyf} &= H_{debyf} = H_{de} + H_{eb} + H_{by} - H_{fd} \\ &= h_e - h_d + L_b + k_2(T_y - T_b) - L_f; \end{aligned}$$

$$\begin{aligned} W_{debzAf} &= H_{debzAf} = H_{de} + H_{eb} + H_{bz} - H_{Af} - H_{fd} \\ &= h_e - h_d + L_b + k_3(T_z - T_b) - k_4(T_A - T_f) - L_f; \end{aligned}$$

in which k_1, k_2, k_3, k_4 , refer to the mean specific heats over the respective pressure and temperature ranges. The efficiencies are obtained by dividing these expressions by the gross amounts of heat absorbed. The equations given in Art. 397 permit of computation of such quantities as are not assumed.

416. Itemized External Work. The pressure and temperature at the beginning of expansion being given, the volume may be computed and the external work during the reception of heat expressed in terms of P and V . The temperature or pressure at the end of expansion being given, the volume may be computed and the negative external work during the rejection of heat calculated in similar terms. The whole work of the cycle, less the algebraic sum of these two work quantities (the feed pump work being ignored), equals the work under the adiabatic, which may be *approximately* checked from the formula $\frac{PV - pv}{n - 1}$, a suitable value being used for n (Art. 394). A second approximation may be made by taking the adiabatic work as equivalent to the decrease in internal energy, which at any superheated state has the value $h + r + \frac{k}{y}(T - t)$, T being the actual temperature, and h, r, t referring to the condition of *saturated* steam at the stated pressure. The most simple method of obtaining the total work of the cycle is to

read from Fig. 177 the "total heat" values at the beginning and end of expansion. (See the author's "Vapors for Heat Engines," D. Van Nostrand Co., 1912.)

417. Comparison of Cycles. In Fig. 183, we have the following cycles:

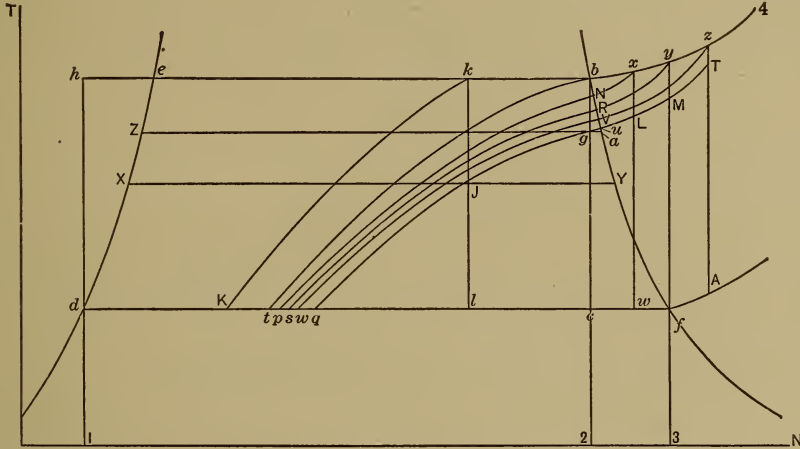

FIG. 183. Arts. 417, 441, 442. — Seventeen Steam Cycles.

- | | |
|----------------------|--|
| Clausius, | with dry steam, $debc$ (the corresponding Carnot cycle being $dhbc$); |
| | with wet steam, $dekl$; |
| Rankine, | with dry steam, $debgq$; |
| | with wet steam, $dekJq$; |
| Non-expansive, | with dry steam, $debt$; |
| | with wet steam, $dekK$; |
| Pambour, | complete expansion, $defb$; |
| | incomplete expansion, $debuq$; |
| Superheated to x , | complete expansion, $debxrw$; |
| | incomplete expansion, $debxLuq$; |
| | no expansion, $debxNp$; |
| Superheated to y , | complete expansion, $debyf$; |
| | incomplete expansion, $debyMuq$; |
| | no expansion, $debyRs$; |
| Superheated to z , | complete expansion, $debzAf$; |
| | incomplete expansion, $debzTuq$; |
| | no expansion, $debzVw$. |

The lines tb , pNx , sRy , wVz , quT , are lines of constant volume. Superheating without expansion would be unwise on either technical or practical grounds; superheating with incomplete expansion is the condition of universal practice in reciprocating engines. The seventeen cycles are drawn to PV coördinates in Fig. 184.

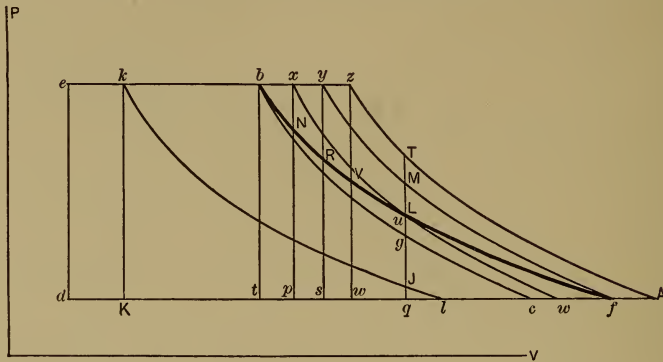

FIG. 184. Arts. 417, 423, 424, 517. — Seventeen Steam Cycles.

ILLUSTRATIVE PROBLEM

To compare the efficiencies, and the cyclic areas as related to the maximum volume attained: let the maximum pressure be 140 lb., the minimum pressure 2 lb., and consider the Clausius cycle (a) with steam initially dry, (b) with steam initially 90 per cent dry; the Rankine with initially dry steam and a maximum volume of 13 cu. ft., the same Rankine with steam initially 90 per cent dry; the non-expansive with steam dry and 90 per cent dry; the Pambour (a) with complete expansion and (b) with a maximum volume of 13 cu. ft.; and the nine types of superheated cycle, the steam being; (a) 96 per cent dry, (b) dry, (c) 40° F. superheated, at the end of complete expansion; and expansion being (a) complete, (b) limited to a maximum volume of 13 cu. ft., (c) eliminated.

I. *Clausius cycle.* The gross heat absorbed is $h_{140} - h_2 + L_{140} = 324.6 - 94.0 + 867.6 = 1098.2$.

The dryness at the end of expansion is $dc + df$, Fig. 183, $= (n_e - n_d + n_{eb}) \div n_{df} = (0.5072 - 0.1749 + 1.0675) \div 1.7431 = 0.803$.

The heat rejected along cd is $x_c L_f = 0.803 \times 1021 = 819.4$.

The work done is $1098.2 - 819.4 = 278.8$ B. t. u. The efficiency is $\frac{278.8}{1098.2} = 0.254$.

The efficiency of the corresponding Carnot cycle is

$$\frac{T_{140} - T_2}{T_{140}} = \frac{353.1 - 126.15}{353.1 + 459.6} = 0.28.$$

II. *Clausius cycle with wet steam.* The gross heat absorbed is $h_{140} - h_2 + x_k L_{140} = 324.6 - 94.0 + (0.90 \times 867.6) = 1015.44$.

The dryness at the end of expansion is $dl + df = (n_e - n_d + n_{ek}) \div n_{df} = (0.5072 - 0.1749 + 0.90 \times 1.0675) \div 1.7431 = 0.741$.

The heat rejected along ld is $x_l L_f = 0.741 \times 1021 = 756$.

The work done is $1015.44 - 756 = 259.44$ B. t. u.

The efficiency is $\frac{259.44}{1015.44} = 0.254$.

(It is in all cases somewhat less than that of the initially dry steam cycle.)

III. Rankine cycle, dry steam. The gross heat absorbed, as in I, is 1098.2.

The work along de , Fig. 184, is $144 \times 138 \times 0.017 = 338.5$ foot-pounds (Art. 407);

along eb is $144 \times 140 \times (V_b - 0.017) = 64,300$ foot-pounds;

$$(V_b = 3.219)$$

along bg is $h_e + r_b - h_g - x_g r_g = 109.76$ B. t. u.

(From Fig. 175, $t_g = 247^\circ$ F., whence $L_g = 947.4$, $V_a = 14.52$, $x_g = \frac{13.0 - 0.017}{14.52 - 0.017} = 0.895$.)

$$\begin{aligned} \text{Also, } x_g &= \frac{n_{zg} - n_e - n_z + n_{eb}}{n_{za} - L_a + T_a} \\ &= \frac{[0.5072 - 2.3(\log T_g - \log 491.6) + 1.0675] T_g}{1433 - 0.695 T_g} \end{aligned}$$

For $T_g = 247^\circ$ F. = 706.6° absolute, this equation gives $x_g = 0.905$; a sufficient check, considering that Fig. 175 is based on a different set of values than those used in the steam table. Then $h_z = 215.4$, $r_g = 871.6$.

The work along qd is $P_a(V_q - V_a) = 144 \times 2 \times (13 - 0.017) = 3740$ foot-pounds.

The whole work of the cycle is $\frac{64300 - 338.5 - 3740}{778} + 109.76 = 187.29$ B. t. u.

The efficiency is $\frac{187.29}{1098.2} = 0.1704$.

IV. Rankine cycle, wet steam. The gross heat absorbed is as in II, 1015.44.

The negative work along de and qd is, as in III, $338.5 + 3740 = 4078.5$ foot-pounds.

The work along ek is $144 \times 140 \times 0.90(V_b - 0.017) = 57,870$ foot-pounds.

The work along kJ is $h_e + x_k r_b - h_x - x_r r_r = 99.8$ B. t. u.

(From Fig. 175, $t_x = 242^\circ$ F., whence $h_x = 210.3$, $r_r = 875.3$, $V_r = 15.78$,

$$x_r = \frac{13 - 0.017}{15.78 - 0.017} = 0.826$$

The whole work of the cycle is $\frac{57870 - 4078.5}{778} + 99.8 = 169.1$ B. t. u.

The efficiency is $\frac{169.1}{1015.44} = 0.1667$.

V. Non-expansive cycle, dry steam. The gross heat absorbed, as in I, is 1098.2.

The work along de , as in III, is 338.5 foot-pounds;

along eb , as in III, is 64,300 foot-pounds;

along td is $p_a(V_b - V_a) = 144 \times 2 \times (3.219 - 0.017) = 922$ foot-pounds.

The whole work of the cycle is

$$64,300 - 338.5 - 922 = 63,039.5 \text{ foot-pounds} = 81.05 \text{ B. t. u.}$$

The efficiency is $\frac{81.05}{1098.2} = 0.074$.

- VI. *Non-expansive cycle, wet steam.* The gross heat absorbed, as in II, is 1015.44. The work along *de, ek*, as in IV, is $-338.5 + 57,870 = 57,531.5$ foot-pounds. The work along *Kd* is

$$p_d(V_K - 0.017) = 144 \times 2 \times 0.90 \times (3.219 - 0.17) = 829.8 \text{ foot-pounds.}$$

The whole work of the cycle is

$$57,531.5 - 829.8 = 56,701.7 \text{ foot-pounds} = 73 \text{ B. t. u.}$$

The efficiency is $\frac{73.0}{1015.44} = 0.0722$.

- VII. *Pambour cycle, complete expansion.* The heat rejected is $L_f = 1021.0$.

The work along *de, eb*, as in III, is $-338.5 + 64300 = 63,961.5$ foot-pounds.

The work along *bf* is

$$\frac{P_b V_b - P_f V_f}{n - 1} = 144 \left(\frac{(140 \times 3.219) - (2 \times 173.5)}{\frac{1}{18} - 1} \right) = 236,800 \text{ foot-pounds.}$$

The work along *fd* is $P_d(V_f - V_d) = 2 \times 144(173.5 - 0.017) = 49,900$ foot-pounds.

The whole work of the cycle is $63,961.5 + 236,800 - 49,900 = 250,861.5$ foot-pounds.

(Otherwise $1433 \log_e \frac{T}{t} - 0.695(T - t) = 312 \text{ B. t. u.} = 242,000$ foot-pounds (Art. 413).)

Using a mean of the two values for the whole work, the gross heat absorbed

$$\text{is } \frac{246430}{778} + 1021 = 1340 \text{ B. t. u. and the efficiency is } \frac{246430}{778 \times 1340} = 0.238.$$

The heat supplied by the jacket is $1340 - 1098.2 = 246.8 \text{ B. t. u.}$

- VIII. *Pambour cycle, incomplete expansion (debuq).* In this case, we cannot directly find the heat rejected, nor can we obtain the work area by integration.* From Fig. 175 (or from the steam table), we find $T_u = 253.8^\circ \text{ F.}$, $P_u = 31.84$. The heat area under *bu* is then, very nearly,

$$\frac{T_u + T_b}{2} (n_u - n_b) = \frac{712.6 + 812.7}{2} (1.6953 - 1.5747) = 92 \text{ B. t. u.}$$

The whole heat absorbed is then $1098.2 + 92 = 1190.2 \text{ B. t. u.}$

The work along *de, eb*, as in VII, is 63,961.5 foot-pounds.

The work along *bu* is $144 \times 16[(140 \times 3.219) - (31.84 \times 13)] = 85,800$ foot-pounds.

The work along *qd*, as in III, is 3740 foot-pounds.

The whole work of the cycle is

$$63,961.5 + 85,800 - 3740 = 146,021.5 \text{ foot-pounds} = 188.2 \text{ B. t. u.}$$

The efficiency is $\frac{188.2}{1190.2} = 0.1585$.

* A satisfactory solution may be had by obtaining the area of the cycle in two parts, a horizontal line being drawn through *u* to *de*. The upper part may then be treated as a complete-expansion Pambour cycle and the lower as a non-expansive cycle. The gross heat absorbed is equal to the work of the upper cycle plus the latent heat of vaporization at the division temperature plus the difference of the heats of liquid at the division temperature and the lowest temperature.

A somewhat similar treatment leads to a general solution for any Rankine cycle: in which, if the temperature at the end of expansion be given, the use of charts becomes unnecessary.

IX. *Superheated cycle, steam 0.96 dry at the end of expansion; complete expansion; cycle debrw.* We have $n_w = n_a + x_w n_{af} = 0.1749 + (0.96 \times 1.7431) = 1.8449$.

The state $x(n_x = n_w)$ may now be found either from Fig. 175 or from the superheated steam table. Using the last, we find $T_x = 931.1^\circ \text{F.}$, $H_x = 1481.8$, $V_x = 5.96$. The whole heat absorbed, measured above T_b , is then

$$1481.8 - 94.0 = 1387.8.$$

The heat rejected is $x_w L_f = 0.96 \times 1021 = 981$.

The external work done is $1387.8 - 981 = 406.8$, and the efficiency is

$$\frac{406.8}{1387.8} = 0.293.$$

(The efficiency of the Carnot cycle within the same temperature limits is

$$\frac{931.1 - 126.15}{931.1 + 459.6} = 0.58.)$$

X. *The same superheated cycle, with incomplete expansion.*

The whole heat absorbed, as before, is 1387.8.

The work done along *de, eb*, as in III, is 63,961.5 foot-pounds.

The work done along *bx* is

$$P_b(V_x - V_b) = 144 \times 140(5.96 - 3.219) = 55,000 \text{ foot-pounds.}$$

The work done along *xL* is

$$\frac{P_x V_x - P_L V_L}{n - 1} = 144 \left(\frac{(140 \times 5.96) - (51.1 \times 13)}{0.298} \right) = 81,500 \text{ foot-pounds.}$$

($V_L = 13$, $P_x V_x^{1.298} = P_L V_L^{1.298}$, $P_L = 140 \left(\frac{5.96}{13} \right)^{1.298} = 51.1$; a procedure

which is, however, only approximately correct (Art. 391).)

The work along *qd*, as in III, is 3740 foot-pounds.

The whole work of the cycle is

$$63,961.5 + 55,000 + 81,500 - 3740 = 196,721.5 \text{ foot-pounds} = 253.5 \text{ B. t. u.}$$

The efficiency is $\frac{253.5}{1387.8} = 0.183$.

XI. *The same superheated cycle, worked non-expansively.* The gross heat absorbed is 1387.8.

The work along *de, eb, bx*, as in X, is 118,961.5 foot-pounds.

The work along *pd* is $2 \times 144 \times (5.96 - 0.017) = 1716$ foot-pounds.

The whole work of the cycle is

$$118,961.5 - 1716 = 117,245.5 \text{ foot-pounds} = 150.6 \text{ B. t. u.}$$

The efficiency is $\frac{150.6}{1387.8} = 0.1086$.

XII. *Superheated cycle, steam dry at the end of expansion, complete expansion; cycle debyf.*

We have $n_y = n_f = 1.918$. This makes the temperature at *y* above the range of our table. Figure 171 shows, however, that at high temperatures the variations in the mean value of *k* are less marked. We may perhaps then extrapolate values in the superheated steam table, giving $T_y = 1120.1^\circ \text{F.}$, $H_y = 1573.5$, $V_y = 6.81$. The whole heat absorbed, above T_b , is then $1573.5 - 94.0 = 1479.5$. The heat rejected is $L_f = 1021$.

The *external work done* is $1479.5 - 1021 = 458.5$ B. t. u., and the *efficiency* is $\frac{458.5}{1479.5} = 0.31$.

XIII. *Superheated cycle as above, but with incomplete expansion.* The *gross heat absorbed* is 1479.5.

The *work done along de, eb*, as in III, is 63,961.5 foot-pounds.

The *work done along by* is $144 \times 140 \times (6.81 - 3.219) = 72,200$ foot-pounds.

The *pressure at M* is $140 \left(\frac{6.81}{13} \right)^{1.298} = 60.3$ pounds, approximately.

The *work done along yM* is $144 \left(\frac{(140 \times 6.81) - (60.3 \times 13)}{0.298} \right) = 81,100$ foot-pounds, also approximately.

The *work done along qd*, as in III, is 3740 foot-pounds.

The *whole work of the cycle* is

$$63,961.5 + 72,200 + 81,100 - 3740 = 213,521.5 \text{ foot-pounds} = 275 \text{ B. t. u.}$$

The *efficiency* is $\frac{275}{1479.5} = 0.187$.

XIV. *Superheated cycle as above, but without expansion.* The *gross heat absorbed* is 1479.5.

The *work along de, eb, by*, as in XIII, is 136,161.5 foot-pounds.

The *work along sd* is $2 \times 144 \times (6.81 - 0.017) = 1952$ foot-pounds.

The *total work* is $136,161.5 - 1952 = 134,209.5$ foot-pounds = 172.7 B. t. u.

The *efficiency* is $\frac{172.7}{1479.5} = 0.117$.

XV. *Superheated cycle, steam superheated 40° F. at the end of expansion; expansion complete; cycle debzAf.* We have $n_A = n_z = 1.9486$. A rather doubtful extrapolation now makes $T_z = 1202.1^\circ$ F., $H_z = 1613.4$, $V_z = 7.18$. The *whole heat absorbed* is $1613.4 - 94.0 = 1519.4$. The *heat rejected* is $H_A = 1133.2$. The *total work* is $1519.4 - 1133.2 = 386.2$ B. t. u., and the *efficiency* is $\frac{386.2}{1519.4} = 0.255$.

XVI. *The same superheated cycle, with incomplete expansion.* The *pressure at T* is

$$140 \left(\frac{7.18}{13} \right)^{1.298} = 65.3 \text{ pounds. The work along zT (approximately) is}$$

$$144 \left(\frac{(140 \times 7.18) - (65.3 \times 13)}{0.298} \right) = 73,900 \text{ foot-pounds. The whole work is}$$

$$63,961.5 + [144 \times 140 \times (7.18 - 3.219)] + 73,900 - 3740 = 213,921.5 \text{ foot-pounds} = 275.3 \text{ B. t. u., and the efficiency is } \frac{275.3}{1519.4} = 0.182.$$

XVII. *The same superheated cycle without expansion.* The *total work* is $63,961.5 + [144 \times 140 \times (7.18 - 3.219)] - [2 \times 144 \times (7.18 - 0.017)] = 141,701.5$ foot-pounds = 182.2 B. t. u., and the *efficiency* is 0.1203.

418. **Discussion of Results.** The saturated steam cycles rank in order of efficiency as follows: Carnot, 0.28; Clausius, with dry steam,

0.254; with wet steam, 0.254 (a greater percentage of initial wetness would have perceptibly reduced the efficiency); Pambour, with complete expansion, 0.238; with incomplete expansion, 0.1585; Rankine, with dry steam, 0.1704; with wet steam, 0.1667; non-expansive, with dry steam 0.074; with wet steam, 0.0722. The economical importance of using initially dry steam and as much expansion as possible is evident. The Pambour type of cycle has nothing to commend it, the average temperature at which heat is received being lowered. The Rankine cycle is necessarily one of low efficiency at low expansion, the non-expansive cycle showing the maximum waste.

Comparing the superheated cycles, we have the following efficiencies:

CYCLE	COMPLETE EXPANSION	INCOMPLETE EXPANSION	NO EXPANSION
<i>debrw</i>	0.293	0.183	0.1086
<i>debyf</i>	0.31	0.187	0.117
<i>debzAf</i>	0.255	0.182	0.1203

The approximations used in solution* will not invalidate the conclusions (a) that superheating gives highest efficiency when it is carried to such an extent that the steam is about dry at the end of complete expansion; (b) that incomplete expansion seriously reduces the efficiency; (c) that in a non-expansive cycle the efficiency increases indefinitely with the amount of superheating. As a general conclusion, the economical development of the steam engine seems to be most easily possible by the use of a superheated cycle of the finally-dry-steam type, with as much expansion as possible. We shall discuss in Chapter XIII what practical modifications, if any, must be applied to this conclusion.

The limiting volumes of the various cycles are

V_c for the Carnot, I, = 139.3.	V_v for IX = 166.5.
V_l for II = 128.2.	V_x for XI = 5.96.
$V_u = V_g$ for III, IV, VIII, X, XIII, XVI = 13.0.	V_y for XIV = 6.81.
V_b for V = 3.219.	V_A for XV = 186.1.
V_k for VI = 2.9.	V_z for XVII = 7.18.
V_f for VII, XII = 173.5.	

* See footnote, Problem 53, page 255.

The *capacity* of an engine of given dimensions is proportional to $\frac{\text{cyclic area}}{\text{maximum volume}}$, which quotient has the following values* :—

Carnot, temperature range \times entropy range

$$= 226.95(1.5747 - 0.1749) = 317.5 : \text{quotient} = \frac{317.5}{139.3} = 2.29.$$

I. 278.8 \div 139.3 = 2.00.	X. 253.5 \div 13 = 19.45.
II. 259.44 \div 128.2 = 2.015.	XI. 150.6 \div 5.96 = 25.3.
III. 187.29 \div 13 = 14.4.	XII. 458.5 \div 173.5 = 2.65.
IV. 169.1 \div 13 = 13.0.	XIII. 275 \div 13 = 21.1.
V. 81.05 \div 3.219 = 25.1.	XIV. 172.7 \div 6.81 = 25.4.
VI. 73.0 \div 2.9 = 25.1.	XV. 386.2 \div 186.1 = 2.075.
VII. 318 \div 173.5 = 1.84.	XVI. 275.3 \div 13 = 21.1.
VIII. 188.2 \div 13 = 14.5.	XVII. 182.2 \div 7.18 = 25.5.
IX. 406.8 \div 166.5 = 2.445.	

Here we find a variation much greater than is the case with the efficiencies; but the values may be considered in three groups, the first including the five non-expansive cycles, giving maximum capacity (and minimum efficiency); the second including the six cycles with incomplete expansion, in which the capacity varies from 13 to 21.1 and the efficiency from 0.1585 to 0.187; and the third including six cycles of maximum efficiency but of minimum capacity, ranging from 1.84 to 2.65. In this group, fortunately, the cycle of maximum efficiency (XII) is also that of maximum capacity.

* The assumption of a constant limiting volume line *Tuq*, Fig. 183, is scarcely fair to the superheated steam cycles. In practice, either the ratio of expansion or the amount of constant volume pressure-drop at the end of expansion is assumed. As the first increases and the second decreases, the economy increases and the capacity figure decreases. The following table suggests that with either an equal pressure drop or an equal expansion ratio the efficiencies of the superheated cycles would compare still more favorably with that of the Rankine :—

CYCLES WITH INCOMPLETE EXPANSION

CYCLE	RATIO OF EXPANSION	PRESSURE DROP
Rankine	$V_g \div V_b = 13 \div 3.219 = 4.04$	$P_g - P_q = 26.3$
Superheat I	$V_L \div V_x = 13 \div 5.96 = 2.185$	$P_L - P_q = 49.1$
Superheat II	$V_M \div V_y = 13 \div 6.81 = 1.91$	$P_M - P_q = 58.3$
Superheat III	$V_T \div V_z = 13 \div 7.18 = 1.815$	$P_T - P_q = 63.3$

Practically, high efficiency means fuel saving and high capacity means economy in the first cost of the engine. The general incompatibility of the two affords a fundamental commercial problem in steam engine design, it being the function of the engineer to establish a compromise.

419. The Ideal Steam Engine. No engine using saturated steam can develop an efficiency greater than that of the Clausius cycle, the attainable temperature limits in present practice being between 100° and 400° F., or, for non-condensing engines, between 212° F. and 400° F. The steam engine is inherently a wasteful machine; the wastes of practice, not thus far considered in dealing with the ideal cycle, are treated with in the succeeding chapter.

THE STEAM TABLES

420. Saturated Steam. The table on pages 247, 248 is abridged from Marks' and Davis' Tables and Diagrams (18). In computing these, the absolute zero was taken at -459.64° F.; the values of h and n_w were obtained from the experiments of Barnes and Dietrici (68) on the specific heat of water; the mechanical equivalent of heat was taken at 777.52; the pressure-temperature relation as found by Holborn and Henning (Art. 360); the thermal unit is the "mean B. t. u." (see footnote, Art. 23); the value of H is as in Art. 388; and the specific volumes were computed as in Art. 368. The symbols have the following significance:—

P = pressure in pounds per square inch, absolute;

T = temperature Fahrenheit;

V = volume of one pound, cubic feet;

h = heat in the liquid above 32° F., B. t. u.;

H = total heat above 32° F., B. t. u.;

L = heat of vaporization = $H - h$, B. t. u.;

r = disgregation work of vaporization = $L - e$ (Art. 359), B. t. u.;

n_w = entropy of the liquid at the boiling point, above 32° F.;

n_e = entropy of vaporization = $\frac{L}{T}$;

n_s = total entropy of the dry vapor = $n_w + n_e$.

421. Superheated Steam. The computations of Art. 417 may suggest the amount of labor involved in solving problems involving superheated steam. This is largely due to the fact that the specific heat of superheated steam is variable. Figure 177, representing Thomas' experiments, may be employed for calculations which do not include volumes; and volumes may be in some cases dealt with by the Linde formula (Art. 363). The most convenient procedure is to use a table, such as that of Heck (71), or of Marks and Davis, in the work already referred to. On the following page is an extract from the latter table. The values of k used are the result of a harmonization of the determinations of Knoblauch and Jakob (Art. 384) and Holborn and Henning (69) and other data (70). They differ somewhat from those given in Fig. 170. The total heat values are obtained by

adding the values of $k(T - t)$ over successive short intervals of temperature to the total heat at saturation; the entropy is computed in a corresponding manner. The specific volumes are from the Linde formula.

PROPERTIES OF SUPERHEATED STEAM

SUPERHEAT, °F	40	90	200	300	400	500	600
Absolute Pressure Lbs. per Square Inch 1	$t = 141.7$	191.7	301.7	401.7	501.7	601.7	701.7
	$V = 357.8$	387.9	453.7	513.4	573.1	632.7	692.4
	$H = 1122.6$	1145.3	1195.6	1241.5	1287.6	1334.1	1381.0
	$n = 2.0069$	2.0434	2.1145	2.1701	2.2218	2.2679	2.4100
2	$t = 166.1$	216.1	326.1	426.1	526.1	626.1	726.1
	$V = 186.1$	201.2	234.2	264.1	293.9	323.8	353.6
	$H = 1133.2$	1156.1	1206.4	1252.4	1298.6	1345.2	1392.2
	$n = 1.9486$	1.9836	2.0529	2.1071	2.1586	2.2044	2.2459
25	$t = 280.1$	330.1	440.1	540.1	640.1	740.1	840.1
	$V = 17.35$	18.61	21.32	23.77	26.20	28.61	31.01
	$H = 1179.6$	1203.4	1255.6	1302.8	1350.1	1397.5	1445.4
	$n = 1.7402$	1.7712	1.8330	1.8827	1.9277	1.9688	2.0078
100	$t = 367.8$	417.8	527.8	627.8	727.8	827.8	927.8
	$V = 4.72$	5.07	5.80	6.44	7.07	7.69	8.31
	$H = 1208.4$	1234.6	1289.4	1337.8	1385.9	1434.1	1482.5
	$n = 1.6294$	1.6600	1.7188	1.7656	1.8079	1.8468	1.8829
140	$t = 393.1$	443.1	553.1	653.1	753.1	853.1	953.1
	$V = 3.44$	3.70	4.24	4.71	5.16	5.61	6.06
	$H = 1215.8$	1242.8	1298.2	1346.9	1395.4	1443.8	1492.4
	$n = 1.6031$	1.6338	1.6916	1.7376	1.7792	1.8177	1.8533
150	$t = 398.5$	448.5	558.5	658.5	758.5	858.5	958.5
	$V = 3.22$	3.46	3.97	4.41	4.84	5.25	5.67
	$H = 1217.3$	1244.4	1300.0	1348.8	1397.4	1445.9	1494.6
	$n = 1.5978$	1.6286	1.6862	1.7320	1.7735	1.8118	1.8474

t = temperature Fahrenheit; V = specific volume; H = total heat above 32° F.; n = entropy above 32° F.

(Condensed from *Steam Tables and Diagrams*, by Marks and Davis, with the permission of the publishers, Messrs. Longmans, Green, & Co.)

PROPERTIES OF DRY SATURATED STEAM

(Condensed from *Steam Tables and Diagrams*, by Marks and Davis, with the permission of the publishers, Messrs. Longmans, Green, & Co.)

<i>P</i>	<i>T</i>	<i>V</i>	<i>h</i>	<i>L</i>	<i>H</i>	<i>r</i>	<i>n_w</i>	<i>n_e</i>	<i>n_s</i>
1	101.83	333.0	69.8	1034.6	1104.4	972.9	0.1327	1.8427	1.9754
2	126.15	173.5	94.0	1021.0	1115.0	956.7	0.1749	1.7431	1.9180
3	141.52	118.5	109.4	1012.3	1121.6	946.4	0.2008	1.6840	1.8848
4	153.01	90.5	120.9	1005.7	1126.5	938.6	0.2198	1.6416	1.8614
5	162.28	73.33	130.1	1000.3	1130.5	932.4	0.2348	1.6084	1.8432
6	170.06	61.89	137.9	995.8	1133.7	927.0	0.2471	1.5814	1.8285
7	176.85	53.56	144.7	991.8	1136.5	922.4	0.2579	1.5582	1.8161
8	182.86	47.27	150.8	988.2	1139.0	918.2	0.2673	1.5380	1.8053
9	188.27	42.36	156.2	985.0	1141.1	914.4	0.2756	1.5202	1.7958
10	193.22	38.38	161.1	982.0	1143.1	910.9	0.2832	1.5042	1.7874
11	197.75	35.10	165.7	979.2	1144.9	907.8	0.2902	1.4895	1.7797
12	201.96	32.36	169.9	976.6	1146.5	904.8	0.2967	1.4760	1.7727
13	205.87	30.03	173.8	974.2	1148.0	902.0	0.3025	1.4639	1.7664
14	209.55	28.02	177.5	971.9	1149.4	899.3	0.3081	1.4523	1.7604
15	213.0	26.27	181.0	969.7	1150.7	896.8	0.3133	1.4416	1.7549
16	216.3	24.79	184.4	967.6	1152.0	894.4	0.3183	1.4311	1.7494
17	219.4	23.38	187.5	965.6	1153.1	892.1	0.3229	1.4215	1.7444
18	222.4	22.16	190.5	963.7	1154.2	889.9	0.3273	1.4127	1.7400
19	225.2	21.07	193.4	961.8	1155.2	887.8	0.3315	1.4045	1.7360
20	228.0	20.08	196.1	960.0	1156.2	885.8	0.3355	1.3965	1.7320
21	230.6	19.18	198.8	958.3	1157.1	883.9	0.3393	1.3887	1.7280
22	233.1	18.37	201.3	956.7	1158.0	882.0	0.3430	1.3811	1.7241
23	235.5	17.62	203.8	955.1	1158.8	880.2	0.3465	1.3739	1.7204
24	237.8	16.93	206.1	953.5	1159.6	878.5	0.3499	1.3670	1.7169
25	240.1	16.30	208.4	952.0	1160.4	876.8	0.3532	1.3604	1.7136
26	242.2	15.72	210.6	950.6	1161.2	875.1	0.3564	1.3542	1.7106
27	244.4	15.18	212.7	949.2	1161.9	873.5	0.3594	1.3483	1.7077
28	246.4	14.67	214.8	947.8	1162.6	872.0	0.3623	1.3425	1.7048
29	248.4	14.19	216.8	946.4	1163.2	870.5	0.3652	1.3367	1.7019
30	250.3	13.74	218.8	945.1	1163.9	869.0	0.3680	1.3311	1.6991
31	252.2	13.32	220.7	943.8	1164.5	867.6	0.3707	1.3257	1.6964
32	254.1	12.93	222.6	942.5	1165.1	866.2	0.3733	1.3205	1.6938
33	255.8	12.57	224.4	941.3	1165.7	864.8	0.3759	1.3155	1.6914
34	257.6	12.22	226.2	940.1	1166.3	863.4	0.3784	1.3107	1.6891
35	259.3	11.89	227.9	938.9	1166.8	862.1	0.3808	1.3060	1.6868
36	261.0	11.58	229.6	937.7	1167.3	860.8	0.3832	1.3014	1.6846
37	262.6	11.29	231.3	936.6	1167.8	859.5	0.3855	1.2969	1.6824
38	264.2	11.01	232.9	935.5	1168.4	858.3	0.3877	1.2925	1.6802
39	265.8	10.74	234.5	934.4	1168.9	857.1	0.3899	1.2882	1.6781
40	267.3	10.49	236.1	933.3	1169.4	855.9	0.3920	1.2841	1.6761
41	268.7	10.25	237.6	932.2	1169.8	854.7	0.3941	1.2800	1.6741
42	270.2	10.02	239.1	931.2	1170.3	853.6	0.3962	1.2759	1.6721
43	271.7	9.80	240.5	930.2	1170.7	852.4	0.3982	1.2720	1.6702
44	273.1	9.59	242.0	929.2	1171.2	851.3	0.4002	1.2681	1.6683
45	274.5	9.39	243.4	928.2	1171.6	850.3	0.4021	1.2644	1.6665
46	275.8	9.20	244.8	927.2	1172.0	849.2	0.4040	1.2607	1.6647
47	277.2	9.02	246.1	926.3	1172.4	848.1	0.4059	1.2571	1.6630
48	278.5	8.84	247.5	925.3	1172.8	847.1	0.4077	1.2536	1.6613
49	279.8	8.67	248.8	924.4	1173.2	846.1	0.4095	1.2502	1.6597
50	281.0	8.51	250.1	923.5	1173.6	845.0	0.4113	1.2468	1.6581

PROPERTIES OF DRY SATURATED STEAM—CONTINUED

(Condensed from *Steam Tables and Diagrams*, by Marks and Davis, with the permission of the publishers, Messrs. Longmans, Green, & Co.)

<i>P</i>	<i>T</i>	<i>V</i>	<i>h</i>	<i>L</i>	<i>H</i>	<i>r</i>	<i>n_w</i>	<i>n_e</i>	<i>n_s</i>
51	282.3	8.35	251.4	922.6	1174.0	844.0	0.4130	1.2435	1.6565
52	283.5	8.20	252.6	921.7	1174.3	843.1	0.4147	1.2402	1.6549
53	284.7	8.05	253.9	920.8	1174.7	842.1	0.4164	1.2370	1.6534
54	285.9	7.91	255.1	919.9	1175.0	841.1	0.4180	1.2339	1.6519
55	287.1	7.78	256.3	919.0	1175.4	840.2	0.4196	1.2309	1.6505
56	288.2	7.65	257.5	918.2	1175.7	839.3	0.4212	1.2278	1.6490
57	289.4	7.52	258.7	917.4	1176.0	838.3	0.4227	1.2248	1.6475
58	290.5	7.40	259.8	916.5	1176.4	837.4	0.4242	1.2218	1.6460
59	291.6	7.28	261.0	915.7	1176.7	836.5	0.4257	1.2189	1.6446
60	292.7	7.17	262.1	914.9	1177.0	835.6	0.4272	1.2160	1.6432
61	293.8	7.06	263.2	914.1	1177.3	834.8	0.4287	1.2132	1.6419
62	294.9	6.95	264.3	913.3	1177.6	833.9	0.4302	1.2104	1.6406
63	295.9	6.85	265.4	912.5	1177.9	833.1	0.4316	1.2077	1.6393
64	297.0	6.75	266.4	911.8	1178.2	832.2	0.4330	1.2050	1.6380
65	298.0	6.65	267.5	911.0	1178.5	831.4	0.4344	1.2034	1.6368
66	299.0	6.56	268.5	910.2	1178.8	830.5	0.4358	1.2007	1.6355
67	300.0	6.47	269.6	909.5	1179.0	829.7	0.4371	1.1972	1.6343
68	301.0	6.38	270.6	908.7	1179.3	828.9	0.4385	1.1946	1.6331
69	302.0	6.29	271.6	908.0	1179.6	828.1	0.4398	1.1921	1.6319
70	302.9	6.20	272.6	907.2	1179.8	827.3	0.4411	1.1896	1.6307
71	303.9	6.12	273.6	906.5	1180.1	826.5	0.4424	1.1872	1.6296
72	304.8	6.04	274.5	905.8	1180.4	825.8	0.4437	1.1848	1.6285
73	305.8	5.96	275.5	905.1	1180.6	825.0	0.4449	1.1825	1.6274
74	306.7	5.89	276.5	904.4	1180.9	824.2	0.4462	1.1801	1.6263
75	307.6	5.81	277.4	903.7	1181.1	823.5	0.4474	1.1778	1.6252
80	312.0	5.47	282.0	900.3	1182.3	819.8	0.4535	1.1665	1.6200
85	316.3	5.16	286.3	897.1	1183.4	816.3	0.4590	1.1561	1.6151
90	320.3	4.89	290.5	893.9	1184.4	813.0	0.4644	1.1461	1.6105
95	324.1	4.65	294.5	890.9	1185.4	809.7	0.4694	1.1367	1.6061
100	327.8	4.429	298.3	888.0	1186.3	806.6	0.4743	1.1277	1.6020
105	331.4	4.230	302.0	885.2	1187.2	803.6	0.4789	1.1191	1.5980
110	334.8	4.047	305.5	882.5	1188.0	800.7	0.4834	1.1108	1.5942
115	338.1	3.880	309.0	879.8	1188.8	797.9	0.4877	1.1030	1.5907
120	341.3	3.726	312.3	877.2	1189.6	795.2	0.4919	1.0954	1.5873
125	344.4	3.583	315.5	874.7	1190.3	792.6	0.4959	1.0880	1.5839
130	347.4	3.452	318.6	872.3	1191.0	790.0	0.4998	1.0809	1.5807
140	353.1	3.219	324.6	867.6	1192.2	785.0	0.5072	1.0675	1.5747
150	358.5	3.012	330.2	863.2	1193.4	780.4	0.5142	1.0550	1.5692
160	363.6	2.834	335.6	858.8	1194.5	775.8	0.5208	1.0431	1.5639
170	368.5	2.675	340.7	854.7	1195.4	771.5	0.5269	1.0321	1.5590
180	373.1	2.533	345.6	850.8	1196.4	767.4	0.5328	1.0215	1.5543
190	377.6	2.406	350.4	846.9	1197.3	763.4	0.5384	1.0114	1.5498
200	381.9	2.290	354.9	843.2	1198.1	759.5	0.5437	1.0019	1.5456
210	386.0	2.187	359.2	839.6	1198.8	755.8	0.5488	0.9928	1.5416
220	389.9	2.091	363.4	836.2	1199.6	752.3	0.5538	0.9841	1.5379
230	393.8	2.004	367.5	832.8	1200.2	748.8	0.5586	0.9758	1.5344
240	397.4	1.924	371.4	829.5	1200.9	745.4	0.5633	0.9676	1.5309
250	401.1	1.850	375.2	825.3	1201.5	742.0	0.5676	0.9600	1.5276

- (1) *Phil. Trans.*, 1854, CXLIV, 360. (2) *Phil. Trans.*, 1854, 333; 1892, 579. (3) *Théorie Mécanique de la Chaleur*, 2d ed., I, 195. (4) Wood, *Thermodynamics*, 1905, 396. (5) Wiedemann, *Ann. der Phys. und Chem.*, 1880, Vol. IX. (6) *Technical Thermodynamics* (Klein), 1907, II, 215. (7) *Mitteilungen über Forschungsarbeiten*, etc., 21; 33. (8) Peabody, *Steam Tables*, 1908, 9; Marks and Davis, *Tables and Diagrams*, 1909, 88; *Phil. Trans.*, 199 A (1902), 149-263. (9) *The Steam Engine*, 1897, 601. (10) *Op. cit.*, II, App. XXX. (11) *The Richards Steam Engine Indicator*, by Charles T. Porter. (12) *Trans. A. S. M. E.*, XI. (13) Dubois ed., II, ii, 1884. (14) Peabody, *op. cit.* (15) *Trans. A. S. M. E.*, XII, 590. (16) *Ann. der Physik*, 4, 26, 1908, 833. (17) *Trans. A. S. M. E.*, XXX, 1419-1432. (18) *Tables and Diagrams of The Thermal Properties of Saturated and Superheated Steam*, 1909. (19) *Zeits. für Instrumentenkunde*, XIII, 329. (20) *Wissenschaftliche Abhandlungen*, III, 71. (21) *Sitzungsberichte K. A. W. in Wien, Math.-natur Klasse*, CVII, II, Oct., 1899. (22) *Loc. cit.*, note (7). (24) *Comptes Rendus*, LXII, 56; *Bull. de la Soc. Instr. de Mulhouse*, CXXXIII, 129. (25) Boulvin's method: see Berry, *The Temperature Entropy Diagram*, 1906, 34. (26) Zeuner, *op. cit.*, II, 207-208. (27) Nichols and Franklin, *Elements of Physics*, I, 194. (28) *Phil. Trans.*, 1869, II, 575. (29) *Zeits. Ver. Deutsch. Ing.*, 1904, 24. (30) *Trans. A. S. M. E.*, XXVIII, 8, 1264. (31) *Ann. der Phys.*, Leipzig, 1905, IV, XVIII, 739. (32) *Zeits. Ver. Deutsch. Ing.*, Oct. 19, 1907. (33) *Mittel. über Forschungsarb.*, XXXVI, 109. (34) *Trans. A. S. M. E.*, XXVIII, 10, 1695. (35) *Trans. A. S. M. E.*, XXIX, 6, 633. (36) *Ibid.*, XXX, 5, 533. (37) *Ibid.*, XXX, 9, 1227. (38) *Op. cit.*, II, 239. (39) Peabody, *Op. cit.*, 111. (40) *The Steam Engine*, 1905, 68. (41) *Trans. A. S. M. E.*, XXIX, 6. (42) *Op. cit.*, II, Apps. XXXIV, XXXV, XL, XLIV, XLII, XXXVIII. (43) *Op. cit.*, 407 *et. seq.* (44) *Op. cit.*, 600. (45) *Comptes Rendus*, CII, 1886, 1202. (46) *Ibid.*, CXIV, 1892, 1093; CXIII, 1891. (47) *Zeits. für die gesamte Kalte-Industrie*, 1895, 66-85. (48) *Op. cit.*, II, App. L. (49) *Machines à froid*, Paris, 1878. (50) Elleau and Ennis, *Jour. Frank. Inst.*, Mar., Apr., 1898; Dietrici, *Zeits. Kälte-Ind.*, 1904. (51) *Op. cit.*, II, App. XLVI. (52) *Zeits. für die gesamte Kalte-Industrie*, 1904. The heavy line across the table on page 422 indicates a break in continuity between the two sources of data. The same break is responsible for the notable irregularity in the saturation and constant dryness curves on the ammonia entropy diagram, Fig. 316. (53) *Tables of the Properties of Saturated Steam and other Vapors*, 1890. (54) See Jacobus, *Trans. A. S. M. E.*, XII. (55) *Jour. Frank. Inst.*, Dec., 1890. (56) *Op. cit.*, 466. (57) *Mem. de l'Institut de France*, XXI, XXVI. (58) Landolt and Börnstein, *Physikalische-chemische Tabellen*; Gmelin; Peabody, *Thermodynamics*, 118. (59) Andréeff, *Ann. Chem. Pharm.*, 1859. (60) *Trans. A. S. M. E.*, XXV, 176. (61) *Tables*, etc., 1890. (62) *Comptes Rendus*, CXIX, 1894, 404-407. (63) *Op. cit.*, App. XLVIII. (64) *Op. cit.*, 468. (65) *Trans. A. S. M. E.*, XII. (66) *Op. cit.*, II, App. XXXII. (67) *Trans. A. S. M. E.*, XXI, 3, 406. (68) *Wied. Annalen*, (4), XVI, 1905, 593-620. (69) *Wied. Annalen*, (4), XVIII, 1905, 739-756; (4), XXIII, 1907, 809-845. (70) Marks and Davis, *op. cit.*, 95. (71) *Trans. A. S. M. E.*, May, 1908.

SYNOPSIS OF CHAPTER XII

The *temperature* remains constant during evaporation; that of the *liquid* is the same as that of the *vapor*; increase of *pressure* raises the *boiling point*, and *vice versa*; it also increases the *density*. There is a definite *boiling point* for each *pressure*.

Saturated vapor is vapor at *minimum temperature* and *maximum density* for the given *pressure*.

Superheated vapor is an imperfect gas, produced by adding heat to a dry saturated vapor.

Saturated Steam

The principal effects of heat are, $h = t - 32$, $e = \frac{P(W - V)}{778}$,

$$r = L - e, H = h + L = h + r + e.$$

As p increases, t , h , e and H increase, and r and L decrease.

$$H = H_{212} + 0.3745(t - 212) - 0.00055(t - 212)^2.$$

$$\text{Factor of evaporation} = \frac{L + (h - h_0)}{970.4}.$$

The pressure increases more rapidly than the temperature.

$$\text{Characteristic equation for steam, } pv = \alpha T - p(1 + bp) \left(\frac{c}{T^3} - d \right).$$

Saturated steam may be *dry* or *wet*. For wet steam,

$$h = h_0, L = xL_0, H = xL_0 + h_0, r = xr_0, e = xe_0,$$

and the factor of evaporation is $\frac{xL + (h - h_0)}{970.4}$. The volume is $W = V + x(W_0 - V)$.

The *water line* shows the volume of water at various temperatures; the *saturation curve* shows the relation between volume and temperature of saturated steam. Approximately, $pv^{1.7} = \text{constant}$. The *isothermal* is a line of constant pressure.

The *path during evaporation* is (a) along the water line (b) across to the saturation curve at constant pressure and temperature. If superheating occurs, the path proceeds at constant pressure and increasing temperature to the right of the saturation curve.

On the *entropy diagram*, the equation of the water line is $n = c \log_e \frac{T}{t}$. The distance

between the water line and the saturation curve is $N = \frac{L}{T}$. *Constant dryness curves* divide this distance in equal proportions. Lines of *constant total heat* may be drawn. The specific heat of steam kept dry is negative. The dryness changes during adiabatic expansion. The *temperature of inversion* is that temperature at which the *specific heat* of dry steam is zero. The change of *internal energy* and the *external work* along any path of saturated steam may be represented on the entropy diagram.

$$W = V + \frac{778 L}{T} \frac{dT}{dP}.$$

Constant volume lines may be plotted on the entropy diagram, permitting of the transfer of any point or path from the PV to the TN plane. The temperature after expansion at constant entropy to a limiting volume can best be obtained from the entropy diagram.

The *critical temperature* is that temperature at which the *latent heat* becomes zero ($689^\circ F.$).

Saturated vapor (dry or wet), superheated vapor, gas; physical states in relation to the critical temperature; shape of isothermals.

The *isodynamic* path for saturated steam touches the saturation curve at one point only.

Sublimation occurs if the saturation pressure at the melting temperature exceeds that of the surrounding medium.

Gas and Vapor Mixtures

Value of R for gas mixtures: mixture of air and steam; absolute and relative humidities; wet and dry bulb thermometers; in mixtures, mixing does not affect the internal energy and adiabatic expansion is without influence on the aggregate entropy.

Mixture and expansion of (a) wet vapor and gas, (b) high-pressure steam and air, (c) superheated steam and air, (d) two vapors. Equivalent values of n . In the heat engine, mixtures may lower the temperature of heat rejection.

Superheated Steam

The *specific heat* has been in doubt. Its value increases with the pressure, and varies with the temperature.

$$H = H_o + k_p(T - t). \quad \frac{k_p}{k_{p1}} = \frac{T_1 - t_1}{T - t}. \quad H_b - H_a = -k_{p1}(T_c - T_b) + k_{p2}(T_d - T_c).$$

$$\text{Factor of evaporation} = \frac{H_{sat} + k_p(T - t) - h_o}{970.4}. \quad PV = 0.64901 T - 22.5819 P^{0.25}.$$

$$PV = 0.594 T - 0.00178 P. \quad R = \pm 85.8. \quad y = \pm 1.298.$$

Paths of Vapors

Adiabatic equation: $\frac{xL}{t} = c \log_e \frac{T}{t} + \frac{XL}{T}$. Approximately, $PV^n = \text{constant}$. Values of n .

External work along an adiabatic = $h - H + xr - XR$.

Continuously superheated adiabatic, e.g.,

$$\log_e \frac{t}{491.6} + \frac{l}{t} + k_1 \log_e \frac{T}{t} = \log_e \frac{u}{491.6} + \frac{L}{u} + k_2 \log_e \frac{U}{u}.$$

Adiabatic crossing the saturation curve:

$$\log_e \frac{t}{491.6} + \frac{l}{t} + k_1 \log_e \frac{T}{t} = \log_e \frac{u}{491.6} + \frac{xL}{u}.$$

Method of drawing constant pressure lines on the entropy diagram: $n = k_p \log_e \frac{T}{t}$.

Method of drawing lines of constant total heat.

Use of the entropy diagram for graphically solving problems: dryness after expansion; work done during expansion; mixing; heat contents.

The *Mollier coördinates*, total heat and entropy. The *total heat-pressure* diagrams.

Vapors in General

$$\frac{dL}{dT} + c - k = \frac{u \cdot dP}{778 dT}, \quad \frac{dL}{dT} + c - k = \frac{L}{T}, \quad V - v = 778 \frac{L}{T} \frac{dT}{dP}.$$

When the pressure-temperature relation and the characteristic equation are given, we may compute L for various temperatures, and the specific heat of the vapor.

Vapors in engineering, *Ammonia*: $\log p = 8.4079 - \frac{2196}{t}$, $\frac{PV}{T} = 91 - \frac{16920}{TV^{0.97}}$, $k = 0.508$,

vapor density = 0.597 (air = 1), specific volume of liquid = 0.025, its specific heat = 1.02. *Sulphur dioxide*: $k = 0.15438$, vapor density = 2.23, specific volume of liquid = 0.0007, its specific heat = 0.4. $PV = 26.4T - 184P^{0.22}$. Pressure-temperature relation. $L = 176 - 0.27(t - 32)$. Engine capacity and economy is influenced by the vapor employed.

Steam Cycles

Efficiency = work done \div gross heat absorbed.

The *Carnot cycle* is impracticable; the steam power plant operates in the *Clausius cycle*.

$$\text{Efficiency of Clausius cycle} = \frac{(T-t) \left(1 + \frac{XL}{T}\right) - t \log_e \frac{T}{t}}{T-t+XL}$$

Rankine cycle (incomplete expansion) — determination of efficiency, with steam initially wet or dry.

$$\text{Non-expansive cycle: efficiency} = \frac{(p_b - p)(xv_b - 0.017)}{h_e - h_d + xL_b}$$

$$\text{Pambour cycle: steam dry during expansion; efficiency} = \frac{1433 \log_e \frac{T}{t} - 0.695(T-t)}{L_f + 1433 \log_e \frac{T}{t} - 0.695(T-t)}$$

computation of heat supplied by jacket.

Superheated cycle: efficiency is increased if the final dryness is properly adjusted and the ratio of expansion is not too low.

Numerical comparison of seventeen cycles for efficiency and capacity: steam should be *initially dry*. The ratio of expansion should be *large* for *efficiency* and *small* for *capacity*.

The Steam Tables

Computation is from p (or t) to t (or p), H , h , L , $\frac{dp}{dt}$, V , e , r , n_w , n_e , n_s .

The superheated tables give n , V , H , t , for various superheats at various pressures; all values depending on H_{sat} , n_{sat} , and k_p .

PROBLEMS

NOTE. Problems not marked T are to be solved without the use of the steam table. In all cases where possible, computed results should be checked step by step with those read from the three charts, Figs. 175, 177, 185.

T 1. The weight per cubic foot of water at 32° F. being 62.42, and at 250.3° F., 58.84, compute in heat units the external work done in heating one pound of water at pressure from 32° to 250.3° . (The pressure is that of saturated steam at a temperature of 250.3° .) (Ans., 0.0055 B. t. u.)

T 1a. 10 lb. of water at 212° are mixed with 20 lb. at 170.06° . What is the total heat per pound, above 32° F., of the resulting mixture?

2. For $p = 100$, $t = 327.8^\circ$, $W = 4.429$, compute h (approximately), H , L , e , r , in the order given. Why do not the results agree with those in the table?

$$(Ans., h = 295.8, H = 1186.3, L = 890.5, e = 81.7, r = 808.8.)$$

T 2a. Water at 90° F. is fed to a boiler in which the pressure is 105 lb. per sq. in. absolute. How much heat must be supplied to evaporate one pound ?

T 3. Find the factor of evaporation for dry steam at 95 lb. pressure, the feed-water temperature being 153° F. (*Ans.*, 1.097.)

T 4. Given the formula, $\log p = c - \frac{2732}{T} - \frac{396945}{T^2}$, T being the absolute temperature and p the pressure per square foot, find the value of $\frac{dp}{dt}$ for $p = 100$ lb. per square inch, $t = 327.8^\circ$ F. Check roughly by observing nearest differences in the steam table.

T 5. What increase in steam pressure accompanies an increase in temperature from 353.1° F. to 393.8° F? Compare the percentages of increase of absolute pressure and absolute temperature.

T 6. Find the values of the constants in the Rankine and Zeuner equations (Art. 363), at 100 lb. pressure.

T 7. From Art. 363, find the volume of dry steam at 240.1° F. in four ways. Compare with the value given in the steam table and explain the disagreement.

8. At 100 lb. pressure, the latent heat per pound is 888.0 ; per cubic foot, it is 200.3. Find the specific volume. (*Ans.*, 4.433.)

9. For the conditions given in Problem 2, W being the volume of *dry* steam, find the five required thermal properties of steam 95 per cent dry. Find its volume.

T 9a. How much heat is consumed in evaporating 20 lb. of water at 90° F. into steam 96 per cent dry at 100 lb. absolute pressure per sq. in.?

T 9b. What is the volume occupied by the mixture produced in Problem 9a ?

T 9c. Five pounds of a mixture of steam and water at 200 lb. pressure have a volume of 3 cu. ft. How much heat must be added to increase the volume to 6 cu. ft. at the same pressure ?

T 9d. A boiler contains 2000 lb. of water and 130 lb. of dry steam, at 100 lb. pressure. What is the temperature ? What are the cubic contents of the boiler ?

T 9e. Water amounting to 100 lb. per min. is to be heated from 55° to 200° by passing through a coil surrounded by steam 90 per cent dry, kept at 100 lb. pressure. What is the minimum weight of steam required per hour ?

T 9f. Water amounting to 100 lb. per min. is to be heated from 55° to 200° by blowing into it a jet of steam at 100 lb. pressure, 90 per cent dry. What is the minimum weight of steam required per hour ?

T 10. State the condition of steam (wet, dry, or superheated) when (a) $p = 100$, $t = 327.8$; (b) $p = 95$, $v = 4.0$; (c) $p = 80$, $t = 360$.

11. Determine the path on the entropy diagram for heating from 200° to 240° F. a fluid the specific heat of which is $1.00 + at$, in which t is the *Fahrenheit* temperature and $a = 0.0044$.

T 12. Find the increases in entropy during evaporation to dry steam at the following temperatures : 228°, 261°, 386° F.

T 13. Compute from Art. 368 the specific volume of dry steam at 327.8° F. What is its volume if 4 per cent wet ? (See Problem 4.)

T 13a. Steam at 100 lbs. pressure 2 per cent wet, is blown into a tank having a capacity of 175 cu. ft. The weight of steam condensed in the tank, after the flow is discontinued, is 60 lb. What weight of steam was condensed during admission ?

T 14. Find the entropy, measured from 32° F., of steam at 327.8° F., 65 per cent dry, (a) by direct computation, (b) from the steam table. Explain any discrepancy.

T 15. Dry steam at 100 lb. pressure is compressed without change of internal energy until its pressure is 200 lb. Find its dryness after compression.

T 16. Find the dryness of steam at 300° F. if the total heat is 800 B. t. u.

T 16a. One pound of steam at 200 lb. pressure occupies 1 cu. ft. What per cent of moisture is present in the steam?

T 17. Find the entropy of steam at 130 lb. pressure when the total heat is 840 B. t. u.

T 18. One pound of steam at 327.8° F., having a total heat of 800 B. t. u., expands adiabatically to 1 lb. pressure. Find its dryness, entropy, and total heat after expansion. What weight of steam was condensed during expansion?

18a. Three pounds of water at 760° absolute expand adiabatically to 660° absolute. What weight of steam is present at the end of expansion? (Use Fig. 175.)

19. Transfer a wet steam adiabatic from the *TN* to the *PV* plane, by the graphical method.

20. Transfer a constant dryness line in the same manner.

21. Sketch on the *TN* and *PV* planes the saturation curve and the water line in the region of the critical temperature.

T 22. At what stage of dryness, at 300° F., is the internal energy of steam equal to that of dry steam at 228° F.?

T 23. At what specific volume, at 300° F., is the internal energy of steam equal to that of dry steam at 228° F.?

T 23a. A boiler contains 4000 lb. of water and 400 lb. of steam, at 200 lb. absolute pressure. If the boiler should explode, its contents cooling to 60° F. and completely liquefying, in 1 sec., how much energy would be liberated? What horse power would be developed during the second following the explosion?

T 24. Compute from the Thomas experiments the total heat in steam at 100 lb. pressure and 440° F.

T 25. Find the factor of evaporation for steam at 100 lb. pressure and 500° F. from feed water at 153° F.

T 26. In Problem 18, find the volume after expansion, and compare with the volume that would have been obtained by the use of Zeuner's exponent (Art. 394). Which result is to be preferred?

T 27. Using the Knoblauch and Jakob values for the specific heat, and determining the initial properties in at least five steps, compute the initial entropy and total heat and the condition of steam after adiabatic expansion from $P=100$, $T=700^\circ\text{F.}$ to $p=13$. Find its volume from the formula in Art. 390. Compare with the volume given by the equation $PV^{1.298}=pv^{1.298}$. (Assume that the superheated table shows the steam to be superheated about 55° F. at the end of expansion.)

T 27a. Steam at 100 lb. pressure, 95 per cent dry, passes through a superheater in which its temperature increases to 450° F. Find the heat added per lb. and the increase of volume.

T 28. Compute the dryness of steam after adiabatic expansion from $P=140$, $T=753.1^\circ\text{F.}$, to $t=153^\circ\text{F.}$ Find the change in volume during expansion.

T 29. Find the external work done in Problems 27 and 28, along the expansive paths.

T 29 a: Three pounds of steam, initially dry, expand adiabatically from 100 lbs. to 1 lb. pressure. Find the initial and final volumes and the external work done.

T 30. At what temperature is the total heat in steam at 100 lb. pressure 1200 B. t. u. ?

31. Find the efficiency of the Carnot cycle between 341.3° F. and 101.83° F.

T 32. Find the efficiency of the Clausius cycle, using initially dry steam between the same temperature limits.

T 33. In Problem 32, find the efficiency if the steam is initially 60 per cent dry.

T 34. In Problem 32, find the efficiency if expansion terminates when the volume is 12 cu. ft. (Rankine cycle).

T 35. In Problem 32, find the efficiency if there is no expansion.

T 36. Find the efficiency of the Pambour cycle between the temperature limits given in Problem 31. How much heat is supplied by the jacket ?

T 37. Find the efficiency of this Pambour cycle if expansion terminates when the volume is 12 cu. ft.

T 38. Steam initially at 140 lb. pressure and 443.1° F. is worked (*a*) in the Clausius cycle, (*b*) in the Rankine cycle, with the same ratio of expansion as in Problem 37. Find the efficiency in each case, the lower temperature being 101.83° F. Find the efficiency of the Rankine cycle in which the maximum volume is 5 cu. ft. (See footnote, Case VIII, Art. 417.)

T 39. At what per cent of dryness is the volume of steam at 100 lb. pressure 3 cu. ft. ?

T 40. Steam at 100 lb. pressure is superheated so that adiabatic expansion to 261° F. will make it just dry. Find its condition if adiabatic expansion is then carried on to 213° F. Find the external work done during the whole expansion.

T 41. Steam passes adiabatically through an orifice, the pressure falling from 140 to 100 lb. When the inlet temperature of the steam is 500° F., its outlet temperature is 494° F.; and when the inlet temperature is 600° F., the outlet temperature is 595° F. The mean value of the specific heat at 140 lb. pressure between 600° F. and 500° F. is 0.498. Find the mean value at 100 lb. pressure between 595° F. and 494° F. How does this value agree with that found by Knoblauch and Jacob ?

T 42. Find from Problem 41 and Fig. 171 the total heat in saturated steam at 140 lb. pressure, in two ways, that at 100 lb. pressure being 1186.3.

T 43. Plot on a total heat-pressure diagram the saturation curve, the constant dryness curve for $x = 0.85$, the constant temperature curve for $T = 500^{\circ}$ F., and a constant volume curve for $V = 13$, passing through both the wet and the superheated regions. Use a vertical pressure scale of 1 in. = 20 lb., and a horizontal heat scale of 1 in. = 20 B. t. u.

44. Compute the temperature of inversion of ammonia, given the equation, $L = 555.5 - 0.613 T^{\circ}$ F., the specific heat of the liquid being 1.0. What is the result if $L = 555.5 - 0.613 T - 0.000219 T^2$ (Art. 401) ?

45. Compute the pressure of the saturated vapor of sulphur dioxide at 60° F. (Art. 404). (Compare Table, page 424.)

T 46. Compare the capacities of the cycles in Problems 31–37, as in Art. 418.

47. Sketch the water line, the saturation curve, an adiabatic for saturated steam, and a constant dryness line on the *PT* plane.

T 48. A 10-gal. vessel contains 0.1 lb. of water and 0.7 lb. of dry steam. What is the pressure?

T 49. A cylinder contains 0.25 lb. of wet steam at 58 lb. pressure, the volume of the cylinder being 1.3 cu. ft. What is the quality of the steam?

T 50. What is the internal energy of the substance in the cylinder in Problem 49?

T 51. Steam at 140 lb. pressure, superheated 400° F., expands adiabatically until its pressure is 5 lb. Find its final quality and the ratio of expansion.

T 52. The same steam expands adiabatically until its dryness is 0.98. Find its pressure.

*T 53.** The same steam expands adiabatically until its specific volume is 50. Find its pressure and quality.

T 54. Steam at 200 lb. pressure, 94 per cent dry, is throttled as in Art. 387. At what pressure must the throttle valve be set to discharge dry saturated steam?

T 55. Steam is throttled from 200 lb. pressure to 15 lb. pressure, its temperature becoming 235.5° F. What was its initial quality? (Use Fig. 175.)

56. Represent on the entropy diagram the factor of evaporation of superheated steam.

57. Check by accurate computations all the values given in the saturated steam table for $t = 180^\circ$ F., using -459.64° F. for the absolute zero, 14.696 lb. per square inch for the standard atmosphere, 777.52 for the mechanical equivalent of heat, and 0.017 as the specific volume of water. Use Thiesen's formula for the pressure:

$$(t + 459.6) \log \frac{p}{14.70} = 5.409(t - 212) - 8.71 \times 10^{-10}[(689 - t)^4 - 477^4];$$

t being the Fahrenheit temperature and p the pressure in pounds per square inch. Use the Knoblauch, Linde and Klebe formula for the volume and the Davis formula for the total heat. Compute the entropy and heat of the liquid in eight steps, using the following values for the specific heat of the liquid:

at 40°,	1.0045;	at 120°,	0.9974;
at 60°,	0.9991;	at 140°,	0.9987;
at 80°,	0.997;	at 160°,	1.0002;
at 100°,	0.99675;	at 180°,	1.0020.

Explain the reasons for any discrepancies.

* This is typical of a class of problems the solution of which is difficult or impossible without plotting the properties on charts like those of Figs. 175, 177, 185. Problem 53 may be solved by a careful inspection of the total heat-pressure and Mollier diagrams, with reasonable accuracy. The approximate analytical solution will be found an interesting exercise. We have no direct formula for relation between V and T , although one may be derived by combining the equations of Rankine or Zeuner (Art. 363) with that in Problem 4. The following expression is reasonably accurate between 200° and 400° F., where v is in cu. ft. per lb. and t is the Fahrenheit temperature:

$$(0.005 t + 0.505)^6 v^{1\frac{1}{2}} = 477.$$

For temperatures between 200° and 260° F., an approximate equation is

$$tv^{\frac{1}{2}} = 477.$$

T'58. Check the properties given in the superheated steam table for $P=25$ with 200° of superheat, using Knoblauch values for the specific heat, in at least three steps, and using the Knoblauch, Linde and Klebe formula for the volume. Explain any discrepancies.

59. Represent on the entropy diagram the temperature of inversion of a dry vapor.

60. Sketch the Mollier Diagram (Art. 399) from $H=0$ to $H=400$, $n=0$ to $n=0.5$.

CHAPTER XIII

THE STEAM ENGINE

PRACTICAL MODIFICATIONS OF THE RANKINE CYCLE

422. The Steam Engine. Figure 186 shows the working parts. The piston P moves in the cylinder A , communicating its motion through the piston rod R , crosshead C , and connecting rod M to the disk crank D on the shaft S , and thus to the belt wheel W . The guides on which the crosshead moves are indicated by G , H , the frame which supports the working parts by F . Journal bearings at B and O support the shaft. The function of the mechanism is to transform the to-and-fro rectilinear motion of the piston to a rotatory movement at the crank. Without entering into details at this point, it may be noted that the valve V , which alternately admits of the passage of steam through either of the ports X , Y , is actuated by a valve rod I traveling from a rocker J , which derives its motion from the eccentric rod N and the eccentric E . In the end view, L is the opening for the admission of steam to the steam chest K , Q is a similar opening for the exit of the steam (shown also in the plan), and V is the valve.

423. The Cycle. With the piston in the position shown, and moving to the left, steam is passing from the steam chest through Y into the cylinder, while another mass of steam, which has expended its energy, is passing from the other side of the piston through the port X and the opening Q to the atmosphere or the condenser. When the piston shall have reached its extreme left-hand position, the valve will have moved to the right, the port Y will have been cut off from communication with K , and the steam on the *right* of the piston will be passing through Y to Q . At the same time the port X will be cut off from Q and placed in communication with K . The piston then makes a stroke to the right, while the valve moves to the left. The engine shown is thus *double-acting*.

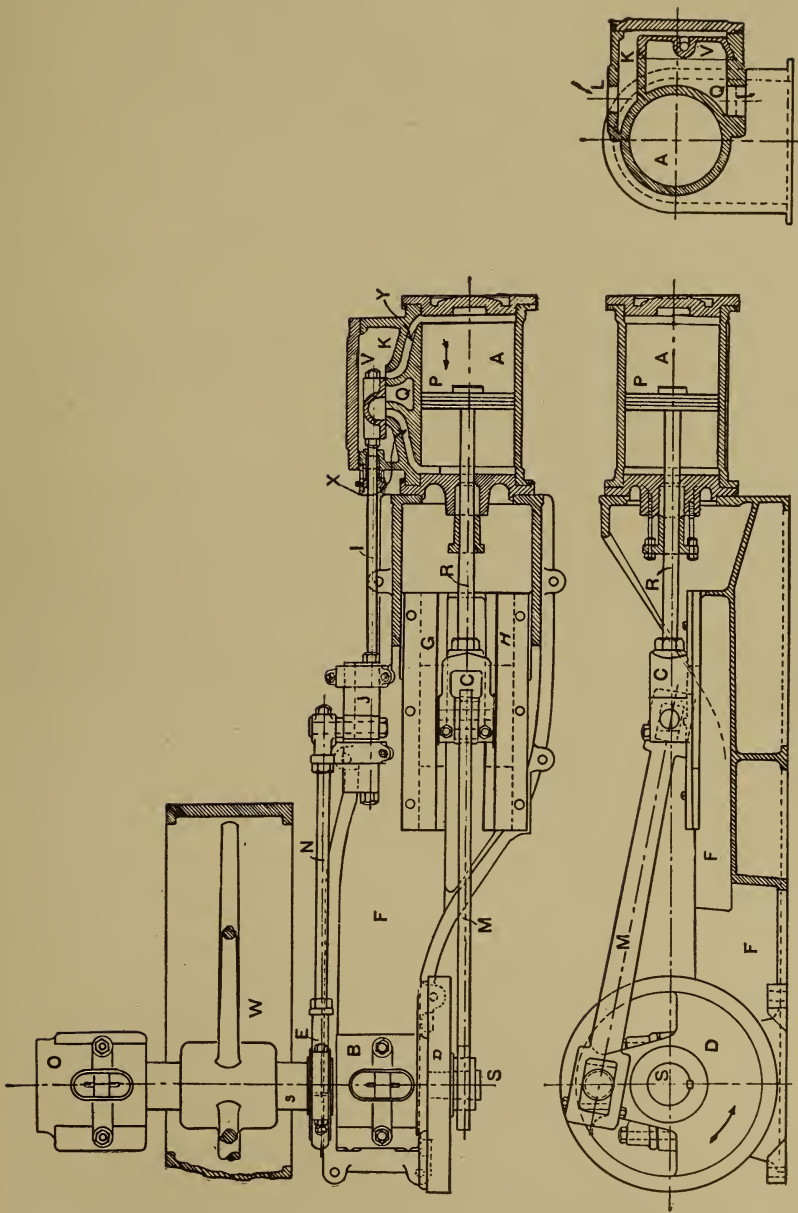

FIG. 186. Arts. 422, 423, 450, 507. — The Steam Engine.

If the valve moved instantaneously from one position to the other precisely at the end of the stroke, the PV diagram representing the changes in the fluid on either side of the piston would resemble $ebtd$, Fig. 184. Along eb , the steam would be passing from the steam chest to the cylinder, the pressure being practically constant because of the comparatively enormous storage space in the boiler, while the piston moved outward, doing work. At b , the supply of steam would cease, while communication would be immediately opened with the atmosphere or the condenser, causing the fall of pressure along bt . The piston would then make its return stroke, the steam passing out of the cylinder at practically constant pressure along td , and at d the position of the valve would again be changed, closing the exhaust and opening the supply and giving the instantaneous rise of pressure indicated by de .

424. Expansion. This has been shown to be an inefficient cycle (Art. 417), and it would be impossible, for mechanical reasons, to more than approximate it in practice. The inlet port is nearly always closed prior to the end of the stroke, producing such a diagram

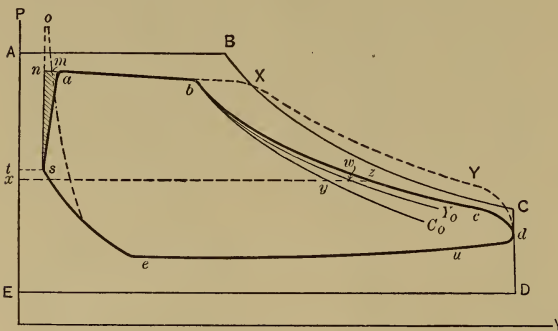

FIG. 187. Arts. 424, 425, 427, 430, 431, 436, 441, 445, 446, 448, 449, 450, 451, 452, 454.—Indicator Diagram and Rankine Cycle.

as $debgq$, Fig. 184, in which the supply of steam to the cylinder is less than the whole volume of the piston displacement, and the work area under bg is obtained without the supply of heat, but solely in consequence of the expansive action of the steam. Apparent-

ly, then, the actual steam engine cycle is that of Rankine* (Art. 411). But if we apply an *indicator* (Art. 484) to the cylinder,—an instru-

* It need scarcely be said that the association of the steam engine indicator diagram and its varying quantity of steam with the ideal Rankine cycle is open to objection (Art. 454). Yet there are advantages on the ground of simplicity in this method of approaching the subject.

ment for graphically recording the changes of pressure and volume during the stroke of the piston, — we obtain some such diagram as *abcde*, Fig. 187, which may be instructively compared with the corresponding Rankine cycle, *ABCDE*. The remaining study of the steam engine deals principally with the reasons for the differences between these two cycles.

425. Wiredrawing. The first difference to be considered is that along the lines *ab*, *AB*. An important reason for the difference in *volumes* at *b* and *B* will be discussed (Art. 430); we may at present note that the *pressures* at *a* and *b* are less than those at *A* and *B*, and that the pressure at *b* is less than that at *a*. This is due to the frictional resistance of steam pipes, valves, and ports, which causes the steam to enter the cylinder at a pressure somewhat less than that in the boiler; and produces a further drop of pressure while the steam enters. The action of the steam in thus expanding with considerable velocity through constricted passages is described as “wiredrawing.” The average pressure along *ab* will not exceed 0.9 of the boiler pressure; it may be much less than this. A loss of work area ensues. The greater part of the loss of pressure occurs in the ports and passages of the cylinder and steam chest. The friction of a suitably designed steam pipe is small. The pressure-drop due to wiredrawing or “throttling,” as it is sometimes called, is greatly aggravated when the steam is initially wet; Clark found that it might be even tripled. Wet steam may be produced as a result of priming or frothing in the boiler, or of condensation in the steam pipes. Its evil effect in this as in other respects is to be prevented by the use of a steam separator near the engine; this automatically separates the steam and entrained moisture, and the water is then trapped away.

426. Thermodynamics of Throttling. Wiredrawing is a *non-reversible* process, in that expansion proceeds, not against a sensibly equivalent external pressure, but against a lower and comparatively non-resistant pressure. If the operation be conducted with sufficient rapidity, and if the resisting pressure be negligible, the external work done should be zero, and the initial heat contents should be equal to the final heat contents; *i.e.*, the steam expands adiabatically (though not isentropically) along a line of constant total heat like *nr*, Fig. 161. The steam is thus dried by throttling; but since the *temperature has been reduced*, the heat has *lost availability*. Figure 188 represents the case in which the steam remains *superheated* throughout the throttling process. *A* is the initial state, *DA* and *EC* lines of constant pressure, *AB* an adiabatic, *AF* a line of constant total heat, and *C* the final state. The areas *SHJDAG* and *SHECK*, and, consequently, the areas *JDABEH* and *GBCK*, are equal; the temperature at *C* is less than that at *A*. (See the superheated steam tables: at $p = 140$, $H = 1298.2$ when $t = 553.1^\circ \text{F.}$;

at $p=100$, $H=1298.2$ when t is about 548° F.) The effect of wire-drawing is generally to lower the temperature, while leaving the total quantity of heat unchanged.

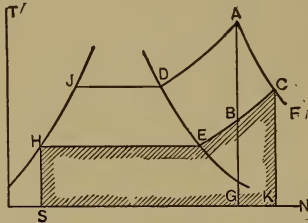

FIG. 188. Art. 426.—Throttling of Superheated Steam.

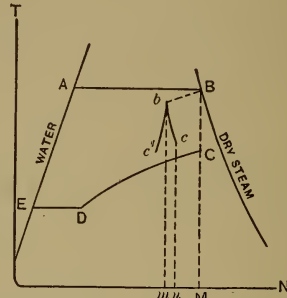

FIG. 189. Arts. 426, 445, 453. Converted Indicator Diagram and Rankine Cycle.

427. Regulation by Throttling. On some of the cheaper types of steam engine, the speed is controlled by varying the extent of opening of the admission pipe, thus producing a wire-drawing effect throughout the stroke. It is obvious that such a method of regulation cannot be other than wasteful; a better method is, as in good practice, to vary the point of cut-off, b , Fig. 187. (See Art. 507.)

428. Expansion Curve. The widest divergence between the theoretical and actual diagrams appears along the expansion lines bc , BC , Fig. 187. In neither shape nor position do the two lines coincide. Early progress in the development of the steam engine resulted in the separation of the three elements, boiler, cylinder, and condenser. In spite of this separation, the cylinder remains, to a certain extent, a condenser as well as a boiler, alternately condensing and evaporating large proportions of the steam supplied, and producing erratic effects not only along the expansion line, but at other portions of the diagram as well.

429. Importance of Cylinder Condensation. *The theoretical analysis of the Rankine cycle (Art. 411) gives efficiencies considerably greater than those actually attained in practice.* The principal reason for this was pointed out by Clark's experiments on locomotives in 1855 (1); and still more comprehensively by Isherwood, in his classic series of engine trials made on a vessel of the United States Navy (2). The further studies of Loring and Emery and of Ledoux (3), and, most of all, those conducted under the direction of Hirn (4), served to point out the vital importance of the question of heat transfers within the cylinder. Recent accurate measurements of the fluctuations in temperature of the cylinder walls by Hall, Callendar and Nicholson (5) and at the Massachusetts Institute of Technology (6) have furnished quantitative data.

430. Initial Condensation. When hot steam enters the cylinder at or near the beginning of the stroke, it meets the relatively cold surface of the piston and cylinder head, and partial liquefaction immediately occurs. By the time the point of cut-off is reached the steam may contain from 25 to 70 per cent of water. The actual weight of steam supplied by the boiler is, therefore, not determined by the volume at b , Fig. 187; it is practically from 33 to 233 per cent greater than the amount thus determined. If $ABCDE$, Fig. 187, represents the ideal cycle, then b will be found at a point where $V_b =$ from $0.30 V_B$ to $0.75 V_B$ (Art. 436).

431a. Behavior during Expansion. The admission valve closes at b , and the steam is permitted to expand. Condensation may continue for a time, the chilling wall surface increasing; but as expansion proceeds the pressure of the steam falls until its temperature becomes less than that of the cylinder walls, when an opposite transfer of heat begins. *The walls now give up heat to the steam*, drying it, *i.e.*, evaporating a portion of the commingled water. The behavior is complicated, however, by the liquefaction which necessarily accompanies expansion, even if adiabatic (Art. 372). The reëvaporation of the water during expansion is effected by a withdrawal of heat from the walls; these are consequently cooled, resulting in the resumption of proper conditions for a repetition of the whole destructive process during the next succeeding stroke. Reëvaporation is an absorption of heat by the fluid. For maximum efficiency, all heat should be absorbed at maximum temperature, as in the Carnot cycle. The later in the stroke that reëvaporation occurs, the lower is the temperature of reabsorption of this heat, and the greater is the loss of efficiency.

431b. Data on Condensation. Even if the cylinder walls were perfectly insulated from the atmosphere, these internal transfers would take place. The Callendar and Nicholson experiments showed that the temperature of the inner surface of the cylinder walls followed the fluctuations of steam temperature, but that the former changes were much less extreme and lagged behind in point of time. Clayton has demonstrated (7) that the expansion curve may be represented (in non-condensing unjacketed cylinders) by the equation

$$pv^n = \text{constant}, \quad n = 0.8x + 0.465,$$

where x is the proportion of dryness at cut-off: the value of n being independent of the initial pressure or ratio of expansion. The initial

wetness is thus the important factor in determining the rate of reëvaporation during expansion. With steam very dry at cut-off (due to jacketing or superheat) heat may be lost throughout expansion. In ordinary cases, the condensation which may occur after cut-off, during the early part of expansion, can continue for a very brief period only: the probability is that in most instances such apparent condensation has been in reality nothing but leakage (Art. 452), and that condensation practically ends at cut-off.

432. Continuity of Action. When unity of weight of steam condenses, it gives up the latent heat L ; when afterward reëvaporated, it reabsorbs the latent heat L_1 ; meanwhile, it has cooled, losing the heat $h-h_1$. The net result is an *increase of heat in the walls* of $L-L_1+h-h_1=H-H_1$, and the walls would continually become hotter, were it not for the fact that heat is being lost by radiation to the external atmosphere and that more water is reëvaporated than was initially condensed; so much more, in fact, that *the dryness at the end of expansion is usually greater than it would have been, had expansion been adiabatic, from the same condition of initial dryness.*

The outer portion of the cylinder walls remains at practically uniform temperature, steadily and irreversibly losing heat to the atmosphere. The inner portion has been experimentally shown to fluctuate in temperature in accordance with the changes of temperature of the steam in contact with it. The depth of this "periodic" portion is small, and decreases as the time of contact during the cycle decreases, *e.g.*, in high speed engines.

433. Influences Affecting Condensation. Four main factors are related to the phenomena of cylinder condensation: they are (a) the *temperature range*, (b) the *size* of the engine, (c) its *speed* and (most important), (d) the *ratio of volumes* during expansion. Of extreme importance, as affecting condensation during expansion, is the *condition of the steam at the beginning of expansion.*

The greater the range of pressures (and temperatures) in the engine, the more marked are the alternations in temperature of the walls, and the greater is the difference in temperature between steam and walls at the moment when steam is admitted to the cylinder. A wide range of working temperatures, although practically as well as theoretically desirable, has thus the disadvantage of lending itself to excessive losses.

434. Speed. At infinite speed, there would be no time for the transfer of heat, however great the difference of temperature. Willans has shown the percentage of water present at cut-off to decrease from 20.2 to 5.0 as the speed increased from 122 to 401 r. p. m., the steam consumption per Ihp-hr. concurrently decreasing from 27.0 to 24.2 lb. (8). In another test by Willans, the speed ranged from 131 to 405 r. p. m., the moisture at cut-off from 29.7 to 11.7, and the steam consumption from 23.7 to 20.3; and in still another, the three sets of figures were 116 to 401, 20.9 to 8.9, and 20.0 to 17.3. In all cases, for the type of engine under considera-

tion, increase of speed decreased the proportion of moisture and increased the economy: but it should not be inferred from this that high speeds are necessarily or generally associated with highest efficiency.

435. Size. The volume of a cylinder is $\pi D^2 L \div 4$ and its exposed wall surface is $(\pi DL) + (\pi D^2 \div 2)$, if D denotes the diameter and L the exposed length. The volume increases more rapidly than the wall surface, as the diameter is increased for a constant length. Since the lengths of cylinders never exceed a certain limit, it may be said, generally, that small engines show greater amounts of condensation, and lower efficiencies, than large engines.

436. Ratio of Expansion. This may be defined as $V_a \div V_b$, Fig. 187 (Art. 450). The greater the ratio of expansion, the greater is the initial condensation. This would be true even if expansion were adiabatic; with early cut-off, moreover, the time during which the metal is exposed to high temperature steam is reduced, and its mean temperature is consequently less. Its activity as an agent for cooling the steam during expansion is thus increased. Again, the volume of steam during admission is more reduced by early cut-off than is the exposed cooling surface, since the latter includes the two constant quantities, the surfaces of the piston and of the cylinder head (clearance ignored—Art. 450). The following shows the results of several experiments:

OBSERVERS	RATIO OF EXPANSION		PER CENT. OF WATER AT CUT-OFF		STEAM CONSUMPTION, POUNDS PER IHP-HR.	
	<i>Low</i>	<i>High</i>	<i>Low</i>	<i>High</i>	<i>Low</i>	<i>High</i>
Loring and Emery	4.2	16.8	21.2	25.1
Willans (9)	4.0	8.0	8.9	25.0	20.7	23.1

Barrus (10) gives the following as average results from a large number of tests of Corliss engines at normal speed:

CUT-OFF, PER CENT. OF STROKE	PERCENTAGE OF CONDENSATION	CUT-OFF, PER CENT. OF STROKE	PERCENTAGE OF CONDENSATION
2.5	62	25.0	24
5.0	54	30.0	20
10.0	44	40.0	16
15.0	36	45.0	15
20.0	28		

In these three sets of experiments, it was found that the proportion of water steadily decreased as the ratio of expansion decreased. The steam consumption, however, **decreased to a certain minimum figure, and then increased** (a feature not shown by the tabulation)—see Fig. 189*a*. The beneficial effect of a decrease in condensation

was here, as in general practice, offset at a certain stage by the thermodynamic loss due to relatively incomplete expansion, discussed in

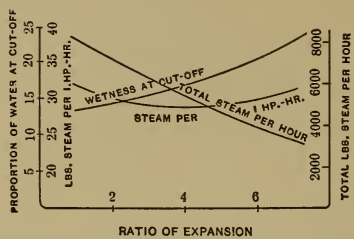

FIG. 189a. Art. 436.—Effect of Ratio of Expansion on Initial Condensation and Efficiency.

Art. 418. The proper balancing of these two factors, to secure best efficiency, is the problem of the engine designer. It must be solved by recourse to theory, experiment, and the study of standard practice. In American stationary engines, the ratio of expansion in simple cylinders is usually from 4 to 5.

437. Quantitative Effect. Empirical formulas for cylinder condensation have been presented by Marks and Heck, among others. Marks (11) gives a curve of condensation, showing the proportion of steam condensed for various ratios of expansion, all other factors being eliminated. A more satisfactory relation is established by Heck (12), whose formula for non-jacketed engines is

$$M = \frac{0.27}{\sqrt[3]{N}} \sqrt{\frac{sT}{pe}}$$

in which M is the proportion of steam condensed at cut-off, N is the speed of the engine (r. p. m.), s is the quotient of the exposed surface of the cylinder in square feet by its volume in cubic feet = $\frac{12}{D} \left(\frac{2D}{L} + 4 \right)$ where D and L are in inches, p is the

TABLE: VALUES FOR T

p_o	Const.	p_o	Const.	p_o	Const.	p_o	Const.
0	170	45	262	115	348	185	409
1	175	50	269½	120	353	190	413
2	179	55	277	125	358	195	416½
3	183	60	284	130	362½	200	420
4	186	65	291	135	367	210	427
6	191	70	297½	140	371½	220	434
8	196	75	304	145	376	230	441
10	200	80	310	150	380½	240	447½
15	210	85	316	155	385	250	454
20	220	90	321½	160	389	260	460½
25	229	95	327	165	393	270	467
30	238	100	332½	170	397	280	473
35	246	105	338	175	401	290	479
40	254	110	343	180	405	300	485

(T in the formula is equal to the difference in constants corresponding with the highest and lowest absolute pressures in the cylinder.)

absolute pressure per square inch at cut-off, e is the reciprocal of the ratio of expansion, and T is a function of the pressure range in the cylinder, which may be obtained from the table on p. 306. Heck estimates that the steam consumption of an engine may be computed from its indicator diagram (Art. 500) within 10 per cent by the application of this formula. If the steam as delivered from the boiler is wet, some modification is necessary.

438. Reduction of Condensation. Aside from careful attention to the factors already mentioned, the principal methods of minimizing cylinder condensation are by (a) the use of *steam-jackets*, (b) *super-heating* the steam, and (c) the employment of *multiple expansion*.

439. The Steam Jacket. Transfers of heat between steam and cylinder walls would be eliminated if the walls could be kept at the momentary temperature of the steam. Initial condensation is eliminated if the walls are kept at the temperature of steam during admission: it is mitigated if the walls are kept from being cooled by the low-pressure steam during the latter part of expansion and exhaust.

The steam jacket, invented by Watt, is a hollow casing enclosing the cylinder walls, within which steam is kept at high pressure. Jackets have often been mechanically imperfect, and particular difficulty has been experienced in keeping them drained of the condensed water. In a few cases, the steam has passed through the jacket on its way to the cylinder; a bad arrangement, as the cylinder steam was thus made wet. It is usual practice, with simple engines, and at the high-pressure cylinders of compounds, to admit steam to the jacket at full boiler pressure; and in some cases the pressure and temperature in the jacket have exceeded those in the cylinder. *Hot-air jackets* have been used, in which flue gas from the boiler, or highly heated air, was passed about the body of the cylinder.

440. Arguments for and against Jackets. The exposed heated surface of the cylinder is increased and its mean temperature is raised; the amount of heat lost to the atmosphere is thus increased. The jacket is at one serious disadvantage: its heat must be transmitted through the entire thickness of the walls; while the internal heat transfers are effected by direct contact between the steam and the inner "skin" of the walls.

Unjacketed cylinder walls act like *heat sponges*. The function of the jacket is preventive, rather than remedial, opposing the formation of moisture early in the stroke, liquefaction being transferred from the cylinder to the jacket, where its influence is less harmful. The walls are kept hot at all times, instead of being periodically heated and cooled

by the action of the cylinder steam. The steam in the jacket does not expand; its temperature is at all times the maximum temperature attained in the cycle. The mean temperature of the walls is thus raised.

441. Results of Jacketing. In the ideal case, the action of the jacket may be regarded as shown by the difference of the areas $dekl$ and $debf$, Fig. 183. The total heat supplied, without the jacket, is $1deb2$, but cylinder condensation makes the steam wet at cut-off, giving the work area $dekl$ only. The additional heat $2bf3$, supplied by the jacket, gives the additional work area $kbf1$, manifestly at high efficiency. In this country, jackets have been generally employed on well-known engines of high efficiency, particularly on slow speed pumping engines; but their use is not common with standard designs. Slow speed and extreme expansion, which suggest jackets, lead to excessive bulk and first cost of the engine. With normal speeds and expansive ratios, the engine is cheaper and the necessity for the jacket is less. The use of the jacket is to be determined from considerations of capital charge, cost of fuel and load factor, as well as of thermodynamic efficiency. These commercial factors account for the far more general use of the jacket in Europe than in the United States.

From 7 to 12 per cent of the whole amount of steam supplied to the engine may be condensed in the jacket. The power of the engine is almost invariably

increased by a greater percentage than that of increase of steam consumption. *The cylinder saves more than the jacket spends*, although in some cases the amount of steam saved has been small. The range of net saving may be from 2 or 3 up to 15 per cent. The increased power of the engine is represented by the difference between the areas $abcde$ and $aXYdes$, Fig. 187. The latter area approaches much more closely the ideal area $ABCDE$. Jacketing pays best when the conditions are such as to naturally induce excessive initial condensation. The diagram of Fig. 190, after Donkin (14), shows the variation in value

of a steam jacket at varying ratios of expansion in the same engine run at constant speed and initial pressure. With the jacket, the best ratio of expansion was about 10, giving 25 lb. of steam per hp.-hr: without the jacket, the lowest steam consumption (of 39 lb. per hp.-hr) was reached at an expansion ratio of 4.

442. Use of Superheated Steam. The thermodynamic advantage of superheating, though small, is not to be ignored, some heat being taken in at a temperature higher than the mean temperature of heat absorption; the practical advantages are more important. Adequate superheat fills the "heat sponge" formed by the walls, without letting the steam become wet in consequence. If superheating is slight, the steam, during admission, may be brought down to the saturated condition, and may even become wet at cut-off, following such a path as $debrbkl$, Fig. 183. With a greater amount of superheat, the steam may remain

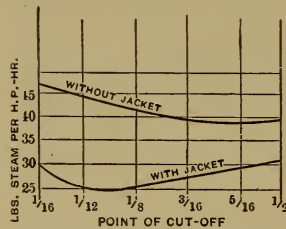

FIG. 190. Art. 441. — Effect of Jackets at Various Expansion Ratios.

dry or even superheated at cut-off, giving the paths *debzyf*, *deb4zA*. The minimum amount of superheat ordinarily necessary to give dryness at cut-off seems to be about 100° F.; it may be much greater. Ripper finds (15) that about 7.5° F. of superheat are necessary for each 1 per cent of wetness at cut-off to be expected when working with saturated steam. We thus obtain Fig. 191, in which the increased work areas *acbd*, *cefb*, *eghf* are obtained by superheating along *jk*, *kl*, *lm*, each path representing 75° of superheat. Taking the pressure along *ag* as 120 lb., and that along *hb* as 1 lb., the absolute temperatures are 800.9° and 561.43°, respectively, and since the latent heat at 120 lb. is 877.2 B. t. u., the work gained by each of the areas in question is

$$87.72 \left(\frac{800.9 - 561.43}{800.9} \right) = 26.1 \text{ B. t. u.}$$

If we take the specific heat of superheated steam, roughly, at 0.48, the heat used in securing this additional work area is $0.48 \times 75 = 36$ B. t. u. The efficiency of superheating is then $26.1 \div 36 = 0.73$, while that of the non-superheated cycle as a whole, even if operated at Carnot efficiency, cannot exceed $239.47 \div 800.9 = 0.30$.

Great care should be taken to avoid loss of heat in pipes between the superheater and the cylinder; without thorough insulation the fall of temperature here may be so great as to considerably increase the amount of superheating necessary to secure the desired result in the cylinder.

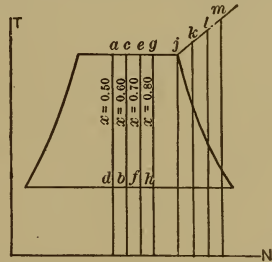

FIG. 191. Art. 442.—Superheat for overcoming Initial Condensation.

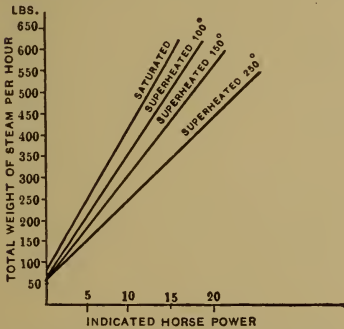

FIG. 193. Art. 443, Prob. 7.—Steam Economy in Relation to Superheat.

temperature here may be so great as to considerably increase the amount of superheating necessary to secure the desired result in the cylinder.

443. Experimental Results with Superheat. The Alsace tests of 1892 showed, with from 60° to 80° of superheat, an average net saving of 12 per cent, based on fuel, even when the coal consumed in the separately fired superheaters was considered; and when the superheaters were fired by waste heat from the boilers, the average saving was 20 per cent. Willans found a considerable saving by superheat, even when cut-off was at half

stroke, a ratio of expansion certainly not unduly favorable to superheating. As with jackets, the advantage of superheat is greatest in engines of low speeds and high expansive ratios. Striking results have been obtained by the use of high superheats, ranging from 200° to 300° F. above the temperature of saturation. The mechanical design of the engine must then be considerably modified. Vaughan

(16) has reported remarkably large savings due to superheating in locomotive practice. Figure 193 shows the decreased steam consumption due to various degrees of superheat in a small high speed engine.

444. Actual Expansion Curve. In Fig. 187, bY_0 represents the curve of constant dryness, bC_0 the adiabatic. The actual expansion curve in an unjacketed cylinder using saturated steam will then be some such line as bc , the entropy increasing in the ratio $xz \div xy$ and the fraction of dryness in the ratio $xz \div xw$. Expressed exponentially, the value of n for such expansion curve depends on the initial dryness (Art. 431b); it is usually between 0.8 and 1.2, and averages about 1.00, when the equation of the curve is $PV = pv$. This should not be confused with the perfect gas isothermal; that the equation has the same form is accidental. The curve $PV = pv$ is an equilateral hyperbola, commonly called the **hyperbolic line**.

The actual expansion path bc will then appear on the entropy diagram, Fig. 189, as bc , bc' , usually more like the former. The point b (cut-off) specifies a lower pressure and temperature than does B in the ideal diagram, and lies to the left of B on account of initial condensation. If expansion is then along bc , the walls are giving up, to the steam, heat represented by the area $mbcn$. This is much less than the area $mbBM$, which represents roughly the loss of heat to the walls by initial condensation.

445. Work done during Expansion: Engine Capacity. From Art. 95, this is, for a hyperbolic curve, BC , Fig. 187, $P_B V_B \log_e \frac{V_C}{V_B}$. Assume no clearance, and admission and exhaust to occur without change of pressure; the cycle is then precisely that represented by $ABCDE$, excepting that the expansive path is hyperbolic. Then the work done during admission is $P_B V_B$; the negative work during exhaust is $P_D V_C$; and the net work of the cycle is

$$P_B V_B + P_B V_B \log_e \frac{V_C}{V_B} - P_D V_C = P_B V_B \left(1 + \log_e \frac{V_C}{V_B} \right) - P_D V_C.$$

The *mean effective pressure* or average ordinate of the work area is obtained by dividing this by V_C , giving

$$\frac{P_B V_B \left(1 + \log_e \frac{V_C}{V_B} \right) - P_D V_C}{V_C}$$

or, letting $\frac{V_C}{V_B} = r$, it is

$$\frac{P_B(1 + \log_e r)}{r} - P_D.$$

Letting m stand for this mean effective pressure, in pounds per square inch, A for the piston area in square inches, L for the length of the stroke in feet, and N for the revolutions per minute, the total average pressure on the piston (ignoring the rod) is mA pounds, the distance through which it is exerted per minute is in a double-acting engine $2LN$ feet, and the work per minute is $2mALN$ foot-pounds, or $2mALN \div 33,000$ horse power. This is for an ideal diagram, which is always larger than the actual diagram *abcde*; the ratio of the latter to the former gives the **diagram factor**, by which the computed value of m must be multiplied to give actual results.

Diagram factors for various types of engine, as given by Seaton, are as follows:

Expansion engine, with special valve gear, or with a separate cut-off valve, cylinder jacketed . . . 0.90;

Expansion engine having large ports and good ordinary valves, cylinders jacketed . . . 0.86 to 0.88;

Expansion engines with ordinary valves and gear as in general practice, and unjacketed . . . 0.77 to 0.81;

Compound engines, with expansion valve on high pressure cylinder, cylinders jacketed, with large ports, etc. . . . 0.86 to 0.88;

Compound engines with ordinary slide valves, cylinders jacketed, good ports, etc. . . . 0.77 to 0.81;

Compound engines with early cut-off in both cylinders, without jackets or separate expansion valves . . . 0.67 to 0.77;

Fast-running engines of the type and design usually fitted in warships . . . 0.57 to 0.77.

The extreme range of values of the diagram factor is probably between 0.50 and 0.90. Regulation by throttling gives values 0.10 to 0.25 lower than regulation by cut-off control. Jackets raise the value by 0.05 to 0.15. Extremely early cut-off in simple unjacketed engines (less than $\frac{1}{3}$) or high speed (above 225 r. p. m.) may decrease it by 0.025 to 0.125. Features of valve and port design may cause a variation of 0.025 to 0.175.

Piston speeds of large engines at around 100 r. p. m. now range from 720 ft. per minute upward. The power output of an engine of given size is almost directly proportional to the piston speed. Rotative speeds (r. p. m.) depend largely on the type of valve gear, and are limited by the strength of the flywheel. Releasing gear engines do not ordinarily run at over 100 r. p. m. (Art. 507): nor do four-valve engines often exceed 240 r. p. m. The smaller engines are apt to have the higher rotative speeds and the larger ratios of cylinder diameter to stroke. Long strokes favor small clearances, with many types of valve. Engines of high rotative speed will generally have short strokes. Speeds of stationary reciprocating engines seldom exceed 325 r. p. m.

446. Capacity from Clayton's Formula. If the expansion curve can be represented by the equation $pv^n = \text{const.}$, in which $n \neq 1$, the mean effective pressure (clearance ignored) is, with the notation of Art. 445,

$$m = \frac{nP_B}{r(n-1)} - P_D - \frac{P_B}{r^n(n-1)}.$$

The best present basis for design is to find n as suggested in Arts. 431b, 437, to assume a moderate amount of hyperbolic compression (see Art. 451) and to allow for clearance. This is in fact the only suitable method for use where there is high superheat: in which case $n > 1.0$.

Thus, let the pressure limits be 120 and 16 lb. absolute, the apparent ratio of expansion 4, clearance 4 per cent, compression to 32 lb. absolute, $n = 1.15$. The approximate equation above gives

$$m = \frac{1.15 \times 120}{0.60} - 16 - \frac{120}{4^{1.15} \times 0.15} = 52 \text{ lb.}$$

More exactly, calling the clearance volume 0.04, the length of the diagram is 1.0, the volume at cut-off is 0.29, and the maximum volume attained is 1.04. The mean effective pressure is

$$m = (120 \times 0.25) + \frac{(120 \times 0.29) - (27.6 \times 1.04)}{0.15} - 16 (1.04 - 0.08) - (30 \times 0.04 \log_e 2) = 54.5 \text{ lb. per square inch,}$$

the pressure at the end of expansion being $120 \left(\frac{0.29}{1.04} \right)^{1.15} = 27.6$ lb. and the volume at the beginning of compression being $0.04 \times \frac{3.2}{8} = 0.08$.

Any diagram factor employed with this method will vary only slightly from 1.0, depending principally upon the type of valve and gear. Unfortunately, we do not as yet possess an adequate amount of information as to values of n in condensing and jacketed engines.

447. Capacity vs. Economy. If we ignore the influence of condensation, the Clausius cycle (Art. 409), objectionable as it is with regard to capacity (Art. 418), would be the cycle of maximum efficiency; practically, when we contemplate the excessive condensation that would accompany anything like complete expansion, the cycle of Rankine is superior. This statement does not apply to the steam turbine (Chapter XIV). The steam engine may be given an enormous range of capacity by varying the ratio of expansion; but when this falls above or below the proper limits, economy is seriously sacrificed. In purchasing engines, the ratio of expansion at **normal** load should be set fairly high, else the **overload** capacity will be reduced. In marine service, economy of fuel is of especial importance, in order to save storage space. Here expansive ratios may therefore range

higher than is common in stationary practice, where economy in first cost is a relatively more important factor.

448. The Exhaust Line: Back Pressure. Considering now the line *de* of Fig. 187, we find a noticeable loss of work area as compared with that in the ideal case. (Line *DE* represents the pressure existing outside the cylinder.) This is due to several causes. The frictional resistance of the ports and exhaust pipes (greatly increased by the presence of water) produces a wiredrawing effect, making the pressure in the cylinder higher than that of the atmosphere or of the condenser. The presence of air in the exhaust passages of a condensing engine may elevate the pressure above that corresponding to the temperature of the steam, and so cause undesirable resistance to the backward movement of the piston. This air may be present as the result of leakage, under poor operating conditions; more or less air is always brought in the cycle with the boiler feed and condenser water. The effect of these causes is to increase the pressure during release, even in good engines, from 1.0 to 3.0 lb. above that ideally obtainable.

Reëvaporation may be incomplete at the end of expansion; it then proceeds during exhaust, sometimes, in flagrant cases, being still incomplete at the end of exhaust. The moisture then present greatly increases initial condensation. The evaporation of any water during the exhaust stroke seriously cools the cylinder walls. In general good practice the steam is about dry during exhaust; or at least during the latter portion of the exhaust.

449. Effect of Altitude. The possible capacity of a non-condensing engine is obviously increased at low barometric pressures, on account of the lowering of the line *DE*, Fig. 187. With condensing engines, the absolute pressure attained along *DE* depends upon the proportion of cooling water supplied and the effectiveness of the condensing apparatus. It is practically independent of the barometric pressure, excepting at very high vacua; consequently, the capacity of the engine is unchanged by variations in the latter. A slightly decreased amount of power, however, will suffice to drive the air pump which delivers the products of condensation against any lessened atmospheric pressure.

450. Clearance. The line *esa* does not at any point come in contact with the ideal line *EA*, Fig. 187. In all engines, there is necessarily a small space left between the piston and the inside of the cylinder head at the end of the stroke. This space, with the port spaces back to the contact surfaces of the inlet valves, is filled with steam throughout the cycle. The distance *ts* in the diagram represents the volume of these "clearance" spaces. In Fig. 195, the apparent ratio of expansion is $\frac{fD}{ab}$. If the zero volume line *OP* be found, the real ratio of expansion, clearance volume included, is $\frac{FD}{Ab}$. The proportion of clearance (always expressed in terms of the piston displacement) is $\frac{Aa}{fD}$. The clearance in actual engines

varies from 2 to 10 per cent of the depending largely on the type of

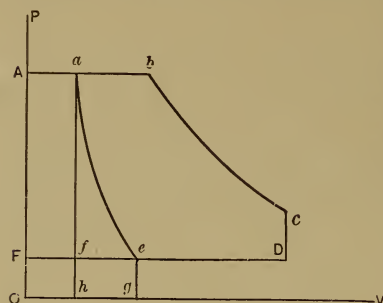

FIG. 135. Arts. 450, 451.—Real and Apparent Expansion.

piston displacement, the necessary amount of valve gear. In such an engine as that of Fig. 186, it is necessarily large, on account of the long ports. In these flat slide valve engines it averages 5 to 10 per cent; with rotary (Corliss) valves, 3 to 8 per cent; with single piston valves, 8 to 15 per cent. These figures are for valves placed on the side (barrel) of the cylinder. When valves are placed on heads, the clearance may be reduced 2 to 6 per cent. In the unidirectional flow (Stumpf) engine (Art. 507), it is only about 2 per cent. It is proportionately greater in small engines than in those of large size.

It may be accurately estimated by placing the piston at the end of the stroke and filling the clearance spaces with a weighed or measured amount of water. All waste spaces, back to the contact surfaces of the valves, count as clearance.

451. Compression. A large amount of steam is employed to fill the clearance space at the beginning of each stroke. This can be avoided by closing the exhaust valve prior to the end of the stroke, as at *e*, Fig. 187, the piston then compressing the clearance steam along *es*, so that the pressure is raised nearly or quite to that of the entering steam. This compression serves to prevent any sudden reversal of thrust at the end of the exhaust stroke. If compression is so complete as to raise the pressure of the clearance steam to that carried in the supply pipe, no loss of steam will be experienced in filling clearance spaces. The work expended in compression, *eahg*, Fig. 195, will be largely recovered during the next forward stroke by the expansion of the clearance steam: the clearance will thus have had little effect on the efficiency; the loss of capacity *efa* will be just balanced by the saving of steam, for the amount of steam necessary to fill the clearance space would have expanded along *ae*, if no other steam had been present.

Complete compression would, however, raise the temperature of the compressed steam so much above that of the cylinder walls that serious condensation would occur. This might be counteracted by jacketing, but in practice it is customary to terminate compression at some pressure lower than that of the entering steam. A certain amount of unresisted expansion then takes place during the entrance of the steam, giving a wiredrawn admission line. If the pressure at *s*, Fig. 187, is fixed, it is, of course, easy to determine the point *e* at which the exhaust valve must close. Considered as a method of warming the cylinder walls so as to prevent initial condensation, compression is "theoretically less desirable than jacketing, for in the former case the heat of the steam, once transformed to work, with accompanying heavy losses, is again transformed into heat, while in the latter, heat is directly applied." For mechanical reasons, some compression is usually considered necessary. It makes the engine smooth-running and probably decreases condensation if properly limited. Compression must not be regarded as bringing about any nearer approach to the Carnot cycle. It is applied to a very small portion only of the working substance, the major portion of which is externally heated during its passage through the steam plant.

452. Valve Action: Leakage. We have now considered most of the differences between the actual and ideal diagrams of Fig. 187. The rounding of the corners at *b*, and along *cd*, is due to sluggish valve action; valves must be opened slightly before the full effect of their opening is realized, and they cannot close instantaneously. The round corner at *e* is due to the slow closing of the exhaust valve. The inclined line *sa* shows the admission of steam, the shaded work area being lost by the slow movement of the valve. In most cases, admission is made to occur slightly prior to the end of the stroke, in order to avoid this very effect. If admission is *too* early, a negative lost work loop, *mno*, may be formed. Important aberrations in the diagram, and modifications of the phenomena of cylinder condensation, may result from leakage past valves or pistons. In an engine like that of Fig. 186, steam may escape directly from the steam chest to the exhaust port. Valves are more apt to leak than pistons. A valve may be tight when stationary, but leak when moving; it may be tight when cold and leak when hot. Unbalanced slide valves, poppet and Corliss valves tend to wear tight; piston valves and balanced slide valves become leaky with wear. Leakage is increased when the steam is wet. Jacketing the cylinder decreases leakage. The steam valve may allow steam to enter the cylinder after the point of cut-off has been passed. Fortunately, as the difference in pressure between steam chest and cylinder increases, the overlap of the valve also increases. Leakage past the exhaust valve is particularly apt to occur just after admission, because then (unless there is considerable compression) the exhaust valve has only just closed.

The indicator diagram cannot be depended on to detect leakage, excepting as the curves are transferred to logarithmic coordinates (7). Such steam valve leakage as has just been described produces the same apparent effect as reëvaporation occurring shortly after cut-off. Leakage from the cylinder to the exhaust, occurring during this period, produces the effect which was formerly regarded as due to cylinder condensation immediately following cut-off. In engines known to have tight exhaust valves, this latter effect is not found.

An engine may be blocked and examined for leakage (*Trans. A. S. M. E.*, XXIV, 719) but it is difficult to ascertain the actual amount under running conditions. In one test of a small engine, leakage was found to be 300 lb. per hour. Tests have shown that with single flat slide or piston valves the steam consumption increases about 15 per cent in from 1 to 5 years, on account of leakage alone. A large number of tests made on all types of engine gave steam consumptions averaging 5 per cent higher where leakage was apparent than where valves and pistons were known to be tight.

THE STEAM ENGINE CYCLE ON THE ENTROPY DIAGRAM

453. Cylinder Feed and Cushion Steam. Fig. 189 has been left incomplete, for reasons which are now to be considered. It is convenient to regard the working fluid in the cylinder as made up of two masses, — the “cushion steam,” which alone fills the compression space at the end of each stroke, and is constantly present, and the “cylinder feed,” which enters at the beginning of each stroke, and leaves before the completion of the next succeeding stroke. In testing steam engines by weighing the discharged and condensed steam, the cylinder feed is alone measured; it alone is chargeable as heat consumption; but for an accurate conception of the cyclical relations in the cylinder, the influence of the cushion steam must be considered.

MT are now drawn for 1 lb. of steam, to any convenient scale, on the entropy plane. To transfer any point, like B , to the entropy diagram, we draw $BD, DK, EH, KT, BA, AT, HT, BG,$ and GF as in Art. 378. Then F is the required point on the temperature entropy diagram. By transferring other points in the same way, we obtain the area $NVFU$. The expansion line thus traced correctly represents the actual history of a definite quantity of fluid; other parts of the diagram are imaginary. It is not safe to make deductions as to the condition of the substance from the NT diagram, excepting along the expansion curve. For example, the diagram apparently indicates that the dryness is decreasing along the exhaust line SU ; although we have seen (Art. 448) that at this stage the dryness is usually increasing (17).

456. Application in Practice. In order to thus plot the entropy diagram, it is necessary to have an average indicator card from the engine, and to know the quantity of steam in the cylinder. This last is determined by weighing the discharged condensed steam during a definite number of strokes and adding the quantity of clearance steam, assuming this to be just dry at the beginning of compression, an assumption fairly well substantiated by experiment.

457a. Reeve's Method. By a procedure similar to that described in Art. 453, an indicator diagram is derived from that originally given, representing the behavior of the cylinder feed alone, on the assumption that the clearance steam works adiabatically through the point e , Fig. 196. This often gives an entropy diagram in which the compression path passes to the left of the water line, on account of the fact that the actual path of the cushion steam is not adiabatic, but is occasionally less "steep."

The Reeve diagram accurately depicts the process between the points of cut-off and release and those of compression and admission with reference to the cylinder feed only.

457b. Preferred Method. The most satisfactory method is to make no attempt to represent action between the points of admission and cut-off and of release and compression. During these two portions of the cycle we know neither the weight nor the dryness of steam present at any point. The method of Art. 455 should be used for the expansion curve alone. For compression, a new curve corresponding with RQ , Fig. 197, should be drawn, representing the pv relation for the weight of *clearance steam alone*. Points along the compression curve may then be transferred to the upper right-hand quadrant by the same process as that described in Art. 455. The TN diagram then shows the expansion and compression curves, both correctly located with reference to the water line OS and the dry steam curve TM , for the respective weights of steam; and the heat transfers and dryness changes during the operations of expansion and compression are perfectly illustrated.

458. Specimen Diagrams. Figure 199 shows the gain by high initial pressure and reduced back pressure. The augmented work areas $befc, cfho,$ are gained at high efficiency; $adjt$ and $adlk$ cost nothing. The operation of an engine at back pressure,

to permit of using the exhaust steam for heating purposes, results in such losses as $ajj_i, adlk$. Similar gains and losses may be shown for non-expansive cycles. Figure 200 shows four interesting diagrams plotted from actual indicator cards from a small

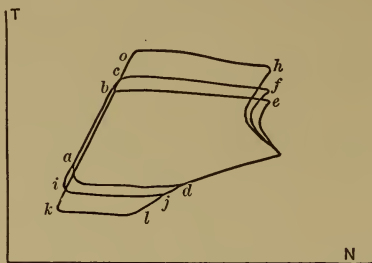

FIG. 199. Art. 458.—Initial Pressure and Back Pressure.

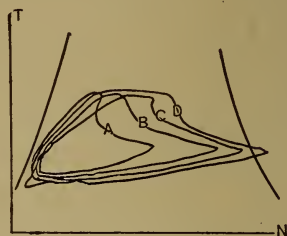

FIG. 200. Art. 458.—Effects of Jacketing and Superheating.

engine operated at constant speed, initial pressure, load, and ratio of expansion (18). Diagrams *A* and *C* were obtained with saturated steam, *B* and *D* with superheated steam. In *A* and *B* the cylinder was unjacketed; in *C* and *D* it was jacketed. The beneficial influence of the jackets is clearly shown, but not the expenditure of heat in the jacket. The steam consumption in the four cases was 45.6, 28.4, 27.25 and 20.9 lb. per lhp-hr., respectively.

MULTIPLE EXPANSION

459. Desirability of Complete Expansion. It is proposed to show that a large ratio of expansion is from every standpoint desirable, excepting as it is offset by increased cylinder condensation; and to suggest multiple expansion as a method for attaining high efficiency by making such large ratio practically possible.

From Art. 416, it is obvious that the maximum work obtainable from a cylinder is a function solely of the initial pressure, the back pressure, and the ratio of expansion. In a non-conducting cylinder, maximum efficiency would be realized when the ratio of expansion became a maximum between the pressure limits. *Without expansion, increase of initial pressure very slightly, if at all, increases the efficiency.* Thus, in Fig. 201, the cyclic work areas $abcd, acfg, ahij$, would all be equal if the line XY followed the law $pv = PV$. As the actual law (locus of points representing steam dry at cut-off) is approximately,

$$pv^{\frac{1}{2}} = PV^{\frac{1}{2}},$$

the work areas increase slightly as the pressure increases; but the necessary heat absorption also increases, and there is no net gain. *The thermodynamic advantage of high initial pressure is realized only when the ratio of expansion is large.*

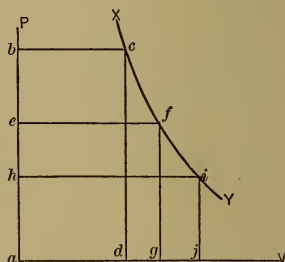

FIG. 201. Art. 459.—Non-expansive Cycles.

By condensing the steam as it flows from the engine, its pressure may be reduced from that of the atmosphere to an absolute pressure possibly 13 lb. lower. The cyclic work area is thus increased; and since the reduction of pressure is ac-

companied by a reduction in temperature, the potential efficiency is increased. Figure 202 shows, however, that the percentage gain in efficiency is small with no expansion, increasing as the expansion ratio increases. Wide ratios of expansion are from all of these standpoints essential to efficiency.

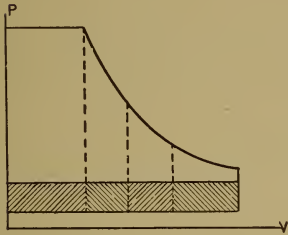

Fig. 202. Art. 439. — Gain due to Vacuum.

We have found, however, that wide ratios of expansion are associated with such excessive losses from condensation that a compromise is necessary, and that in practice the best efficiency is secured with a rather limited ratio. The practical attainment of large expansive ratios without corresponding losses by condensation is possible by multiple expansion. By allowing the steam to pass successively through two or more cylinders, a total expansion of 15 to 33 may be secured, with condensation losses such as are due to much lower ratios.

460. Condensation Losses in Compound Cylinders. The range of pressures, and consequently of temperatures, in any one cylinder, is reduced by compounding. It may appear that the sum of the losses in the two cylinders would be equal to the loss in a single simple cylinder. Three considerations may serve to show why this is not the case:

(a) Steam reëvaporated during the exhaust stroke is rendered available for doing work in the succeeding cylinder, whereas in a simple engine it merely causes a resistance to the piston;

(b) Initial condensation is decreased because of the decreased fluctuation in wall temperature;

(c) The range of temperature in each cylinder is half what it is in the simple cylinder, but the whole wall surface is not doubled.

461. Classification. Engines are called **simple**, **compound**, **triple**, or **quadruple**, according to the number of successive expansive stages, ranging from one to four. A multiple-expansion engine may have any number of cylinders; a triple expansion engine may, for example, have five cylinders, a single high-pressure cylinder discharging its steam to two succeeding cylinders, and these to two more. In a multiple-expansion engine, the first is called **high-pressure cylinder** and the last the **low-pressure cylinder**. The second cylinder in a triple engine is called the **intermediate**; in a quadruple engine, the second and third are called the **first intermediate** and the **second intermediate** cylinders, respectively. Compound engines having the two cylinders placed end to end are described as *tandem*; those having the cylinders side by side are *cross-compound*. This last is the type most commonly used in high-grade stationary plants in this country. The engines may be either **horizontal** or **vertical**; the latter is the form generally used for triples or quadruples, and in marine service. Sometimes some of the cylinders are horizontal and others vertical, giving what, in the two-expansion type, has been called the **angle compound**. Compounding may be effected (as usually) by using cylinders of various diameters and equal strokes; or of equal diameters and varying strokes,

or of like dimensions but unequal speeds (the cylinders driving independent shafts), or by a combination of these methods.

462. Incidental Advantages. Aside from the decreased loss through cylinder condensation, multiple-expansion engines have the following points of superiority:

(1) The steam consumed in filling clearance spaces is less, because the high-pressure cylinder is smaller than the cylinder of the equivalent simple engine;

(2) Compression in the high-pressure cylinder may be carried to as high a pressure as is desirable without beginning it so early as to greatly reduce the work area;

(3) The low-pressure cylinder need be built to withstand a fraction only of the boiler pressure; the other cylinders, which carry higher pressures, are comparatively small;

(4) In most common types, the use of two or more cylinders permits of using a greater number of less powerful impulses on the piston than is possible with a single cylinder, thus making the rotative speed more uniform;

(5) For the same reason, the mechanical stresses on the crank pin, shaft, etc., are lessened by compounding.

These advantages, with that of superior economy of steam, have led to the general use of multiple expansion in spite of the higher initial cost which it entails, wherever steam pressures exceed 100 lb.

463. Woolf Engine. This was a form of compound engine originated by Hornblower, an unsuccessful competitor of Watt, and revived by Woolf in 1800, after the expiration of Watt's principal patent. Steam passed directly from the high to the low-pressure cylinder, entering the latter while being exhausted from the former. This necessitated having the pistons either in phase or a half revolution apart, and there was no improvement over any other double-acting engine with regard to uniformity of impulse on the piston. Figure 203 represents the ideal indicator diagrams. $ABCD$ is the action in the high-pressure cylinder, the fall of pressure along CD being due to the increase in volume of the steam, now passing into the low-pressure cylinder and forcing its piston outward. $EFGH$ shows the action in the low-pressure cylinder; steam is entering continuously throughout the stroke along EF . By laying off $MP = LK$, etc., we obtain the diagram $TABRS$, representing the changes undergone by the steam during its entire action. This last area is obviously equal to the sum of the areas $ABCD$ and $EFGH$. Figure 204, from Ewing (19) shows a pair of actual diagrams from a Woolf engine, the length of the diagrams representing

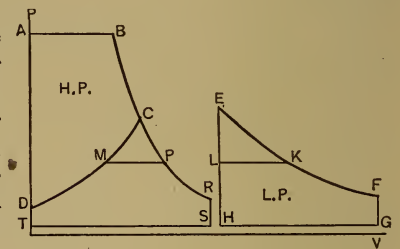

FIG. 203. Arts. 463, 466. — Woolf Engine.



FIG. 204. Art. 463, Prob. 31. — Diagrams from Woolf Engine.

the length of the diagrams representing

the stroke of the pistons and not actual steam volumes. The low-pressure diagram has been reversed for convenience. Some *expansion* in the low-pressure cylinder occurs after the closing of the high-pressure exhaust valve at *a*. Some loss of pressure by wiredrawing in the passages between the two cylinders is clearly indicated.

464a. Receiver Engine. In this more modern form the steam passes from the high-pressure cylinder to a closed chamber called the *receiver*, and thence to the low-pressure cylinder. The receiver is usually an independent vessel connected by pipes with the cylinders; in some cases, the intervening steam pipe alone is of sufficient capacity to constitute a receiver. Receiver engines may have the pistons coincident in phase, as in *tandem* engines, or opposite, as in *opposed beam* engines, or the cranks may be at an angle of 90° , as in the ordinary *cross-compound*. In all cases the receiver engine has the characteristic advantage over the Woolf type that the low-pressure cylinder need not receive steam during the whole of the working stroke, but may have a definite point of cut-off, and work in an expansive cycle. The distribution of work between the two cylinders, as will be shown, may be adjusted by varying the point of cut-off on the low-pressure cylinder (Art. 467).

Receiver volumes vary from $\frac{1}{2}$ to $1\frac{1}{2}$ times the high-pressure cylinder volume.

464b. Reheating. A considerable gain in economy is attained by drying or superheating the steam during its passage through the

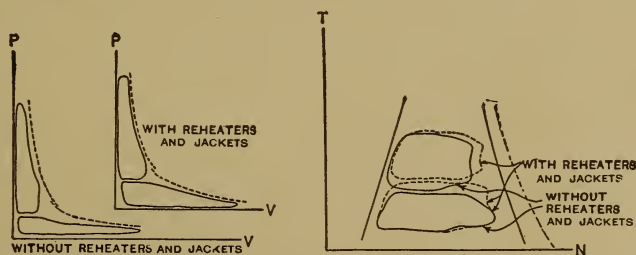

FIGS. 215 and 216. Art. 464b.—Effect of Reheaters and Jackets (25).

receiver, by means of pipe coils supplied with high-pressure steam from the boiler, and drained by a trap. The argument in favor of reheating is the same as that for the use of superheat in any cylinder (Art. 442). It is not surprising, therefore, that the use of reheaters is only profitable when a considerable amount of intermediate drying is effected. Reheating was formerly unpopular, probably because of the difficulty

of securing a sufficient amount of superheat with the limited amount of coil surface when saturated steam was used in the receiver coils. With superheated steam, this difficulty is obviated. Reheating increases the capacity as well as the economy of the cylinders.

465. Drop. The fall of pressure occurring at the end of expansion (*cd*, Fig. 196) is termed *drop*. Its thermodynamic disadvantage and practical justification have been pointed out in Arts. 418, 447. In a compound engine, some special considerations apply. If there is no drop at high-pressure release, the diagram showing the whole expansion is substantially the same as that for a simple cylinder. With drop, the diagram is modified, the ratio of expansion in the high-pressure cylinder is decreased, and the ideal output is less.

The orthodox view is that there should be no drop in the high-pressure cylinder (21). The cylinders of a compound engine work with less fluctuation of temperature than that of a simple engine, and may therefore be permitted to use higher ratios of expansion (i.e., less drop) than does the latter. In the design method to follow, dimensions will be determined as for no drop. Changes of load from normal may introduce varying amounts of drop in operation.

466. Combination of Actual Diagrams: Diagram Factor. Figure 210 shows the high- and low-pressure diagrams from a small compound engine. These are again

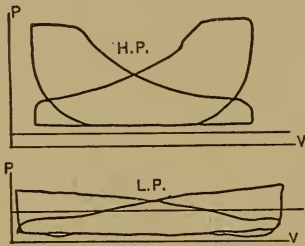

FIG. 210. Art. 466.—Compound Engine Diagrams.

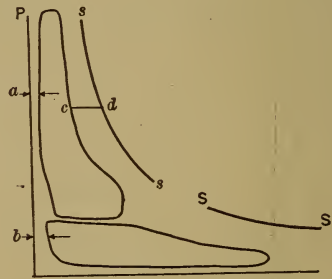

FIG. 211. Art. 466.—Compound Engine Diagrams Combined.

shown in Fig. 211, in which the lengths of the diagrams are proportioned as are the cylinder volumes, the pressure scales are made equal, and the proper amounts of setting off for clearance (distances *a* and *b*) are regarded. The cylinder feed per single stroke was 0.0498 lb., the cushion steam in the high-pressure cylinder 0.0074 lb., and that in the other cylinder 0.0022 lb. No single saturation curve is possible; the line *ss* is drawn for 0.0572 lb. of steam, and *SS* for 0.0520 lb. As in Art. 453, we may obtain equivalent diagrams with the cushion steam eliminated.

In Fig. 212, the single curve *SS* then represents saturation for 0.0498 lb. of steam. The areas of the diagrams are unaltered, and correctly measure the work done; they may be transferred to the entropy plane as in Art. 455. The moisture present at any point during expansion is still represented by the distance *cd*, corresponding with the distances similarly marked in Fig. 211. The ratio of the area of the combined actual diagrams to that of the Rankine cycle through the same extreme limits of pressure and with the same ratio of expansion is the *diagram factor*, the value of which may range up to 0.95, being higher than in simple engines (Art. 459).

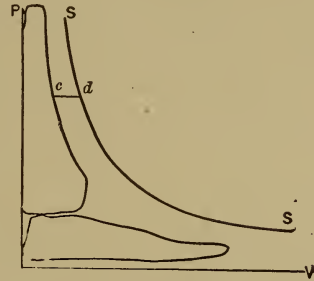

FIG. 212. Art. 466. — Combined Diagrams for Cylinder Feed.

467. Combined Diagrams. Figure 205 shows the ideal diagrams from a tandem receiver engine. Along *CD*, as along *CD* in Fig. 203, expansion into the low-pressure cylinder is taking place. The corresponding line on the low-pressure diagram is *EF*. At *F* the supply of steam is cut off from the low-pressure cylinder, after which hyperbolic expansion occurs along *FS*. Meanwhile, the

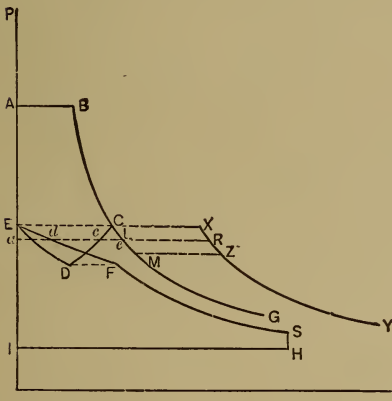

FIG. 205. Arts. 467, 475.—Elimination of Drop, Tandem Receiver Engine.

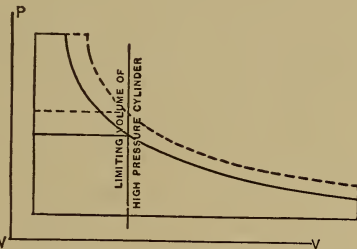

FIG. 214. Art. 468.—Effect of Low-pressure Cut-off.

exhaust from the high-pressure cylinder is discharged to the receiver; and since a constant quantity of steam must now be contained in the decreasing space between the piston and the cylinder and receiver walls, some compression occurs, giving the line *DE*. The pressure of the receiver steam remains equal to that at *E* after the high-pressure exhaust valve closes (at *E*) and while the high-pressure cylinder continues the cycle along *EABC*. If the pressure at *C* exceeds that at *E*, then there will be some *drop*. As drawn, the diagram shows none. If cut-off in the low-pressure cylinder occurred later in the stroke, the line *DE* would be lowered, P_C would exceed P_E , and drop would be shown.

An incidental advantage of the receiver engine is here evident. The introduction of cut-off in the low-pressure cylinder raises the lower limit of tempera-

ture in the high-pressure cylinder from D in Fig. 203 to D in Fig. 205. This reduced range of temperature decreases cylinder condensation.

468. Governing Compound Engines. Fig. 214 shows that delayed cut-off on the high-pressure cylinder greatly increases the output of the low-pressure cylinder while (the receiver pressure being raised) scarcely affecting its own output.

In Fig. 206, is shown the result of varying low-pressure cut-off in a tandem receiver engine with drop, the low-pressure clearance being exaggerated for clearness.

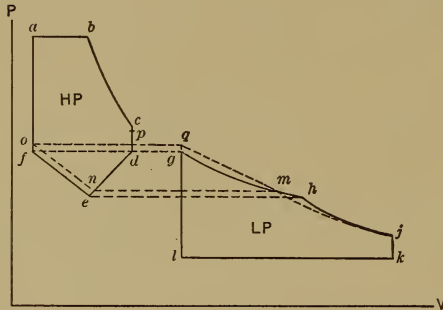

FIG. 206. Art. 468.—Effect of Changing Low-pressure Cut-off.

exaggerated for clearness. The high-pressure diagram is $fabcde$, the low-pressure is $ghijkl$, $p_f = p_a = p_o$ and $p_e = p_h$. Low-pressure cut-off occurs at h (point e in the high-pressure diagram). If this event occur earlier, the corresponding point on the high-pressure diagram is made (say) n , and compression then raises the receiver pressure to o instead of f . The result is that the

drop decreases to cp instead of cd ($p_p = p_o$). The admission pressure of the low-pressure cylinder thus becomes $p_q = p_p = p_o$ instead of p_o , and the gain qmg due to such increased pressure more than offsets the loss mhi due to the fact that low-pressure cut-off now occurs at $p_m = p_n$. The same results will be found with cross-compound engines.

The total output of the engine is very little affected by changes in low-pressure cut-off: but (contrary to the result in simple cylinders) the output of the low-pressure cylinder varies directly as its ratio of expansion. With delayed cut-off, the low-pressure cylinder performs a decreased proportion of the total work.

When the load changes in a compound engine which has a fixed point of low-pressure cut-off, equality of work distribution becomes impossible. The output of the engine should be varied by varying the point of high-pressure cut-off. Equal distribution of the work should then be accomplished by variation of low-pressure cut-off. The two points of cut-off will be changed *in the same direction* as the load changes. At other than normal load, there will then be some drop. *The aim in design will be, after fixing upon a suitable receiver pressure, to select a normal corresponding point of low-pressure cut-off at which, with the given receiver volume and cylinder ratio, drop will be eliminated.* (Arts. 475-478).

DESIGN OF COMPOUND ENGINES

469. Preliminary Diagram. We first consider the action as represented in Fig. 205, which shows the combined ideal diagrams without clearance or compression, and with hyperbolic expansion. Losses or gains between the cylinders are ignored. The following notation is adopted:

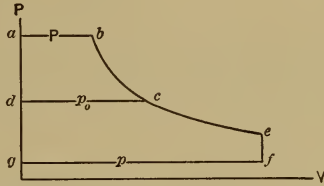

FIG. 205. Arts. 469, 470, 473.—Preliminary Compound Engine Diagram.

P = initial absolute pressure, lb. per sq. in., along ab ;

p_o = receiver absolute pressure, lb. per sq. in.; along dc ;

p = back pressure, absolute, lb. per sq. in., along gf ;

p_{mh} = mean effective pressure, lb. per sq. in., high-pressure cylinder;

p_{ml} = mean effective pressure, lb. per sq. in., low-pressure cylinder;

$\frac{v_e}{v_b} = R_h$ = ratio of expansion, high-pressure cylinder;

$\frac{v_e}{v_c} = R_l$ = ratio of expansion, low-pressure cylinder;

$\frac{v_e}{v_b} = R$ = whole ratio of expansion;

$\frac{v_e}{v_c} = C$ = ratio of cylinder volumes, or "cylinder ratio."

The following relations are useful:

$$R = R_h R_l = C R_h; \quad C = R_l; \quad p_{mh} = \frac{PC}{R} \log_e \frac{R}{C};$$

$$p_{ml} = \frac{P}{R} (1 + \log_e C) - p.$$

470. Bases for Design. The values of P , p and R being given, whatever fixes the pressure or volume at c determines the proportions of the engine. We may assume either *

(a) the receiver pressure, p_o ;

(b) the cylinder ratio, $C = \frac{v_e}{v_c}$;

(c) equal division of the temperature ranges; that is,

$$T_b - T_c = T_c - T_f, \quad \text{or} \quad T_c = \frac{T_b + T_f}{2},$$

* Some designers of marine engines aim at equalization of maximum pressures on the cranks. This requires careful consideration of clearance and compression.

and p_o is the pressure corresponding with the temperature T_c ; or,

(d) equal division of the work; that is, $abcd = dcefg$, attained when

$$\log_e C = \left(\log_e R + \frac{R_p}{P} - 1 \right) \div 2.$$

Any one of these four assumptions may be made, but not more than one. Having made one, the pressures and volumes at b, c, e and f are all fixed.

471. Diagrams with Clearance. We now employ Fig. 213, in which clearance is allowed for. The expansion curve is still assumed to be a continuous hyperbola, and inter-cylinder losses are ignored. (These last need not be important.)

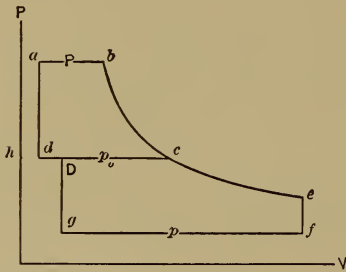

If d_h is the high-pressure clearance ($=hd \div dc$, Fig. 213), the apparent ratio of expansion in the high-pressure cylinder is

$$R_h' = \frac{dc}{ab} = \frac{R_h - d_h R_h}{1 - d_h R_h}.$$

FIG. 213. Arts. 471-473. — Design Diagram, Compound Engine.

Similarly, the apparent ratio of expansion in the low-pressure cylinder is

$$R_l' = \frac{R_l - d_l R_l}{1 - d_l R_l},$$

where $d_l = \frac{hd}{gf}$ is the low-pressure clearance. Engines are usually designed by specifying the whole apparent ratio of expansion, $(dD + gf) \div ab$. In terms of the real ratios, this is

$$R' = \frac{R(1 + d_h) - R_h d_h}{1 + d_h - R_h d_h}.$$

The mean effective pressures in the cylinders are now

$$p_{mh} = \frac{P}{R_h'} + \frac{P}{R_h} (1 + d_h) \log_e R_h - p_o,$$

$$p_{ml} = \frac{p_o}{C} + \frac{p_o}{R_l'} (1 + d_l) \log_e R_l - p,$$

and $R_l = C$ only when $d_h = d_l$.

The mean effective pressures reached in practice will differ from these by some small amount, the ratio of probable actual to computed pressure being described as the *diagram factor*. Generally speak-

ing, the diagram factor to be used for the cylinder of a multiple expansion engine of n expansion stages and R ratio of expansion is the same as that for a simple engine of expansion ratio R_s , when

$$R_s = \sqrt[n]{R}.$$

472. Size and Horse Power. In general, diagram factors, piston speeds and strokes are the same for all the cylinders of the engine. Then following Art. 446,

$$\text{hp.} = \frac{2fLN}{33000} (p_{mh}A_h + p_{ml}A_l,$$

where f = diagram factor and A_h and A_l are the areas of high and low-pressure cylinders respectively, in sq. in. Letting C denote the cylinder ratio,

$$\text{hp.} = \frac{2fLNA_l}{33000} \left(\frac{p_{mh}}{C} + p_{ml} \right),$$

in which $\frac{p_{mh}}{C}$ describes what is called the "high-pressure mean-effective pressure referred to the low-pressure cylinder."

473. Division of Work: Equivalent Simple Engine. The work will be divided between the cylinders in the same ratio as the two areas $abcd$, $Dcefg$, Fig. 213; or in the ratio,

$$p_{mh} \div Cp_{ml}.$$

When the assumption of equal output is made (Art. 469), the mean effective pressures must be inversely as the cylinder areas.

The power of the compound engine is very nearly the same as that which would be obtained from a simple cylinder of the same size as the low-pressure cylinder of the compound, with a ratio of expansion equal to the whole ratio of expansion of the compound. This would be *exactly* true if the diagram factor were the same for the simple as for the compound and if the no-clearance diagram, Fig. 213, were used for finding p_m . An approximate expression for the area of the low-pressure cylinder of a compound is then

$$\text{hp.} = \frac{2fLNA_l}{33000} \left\{ \frac{P(1 + \log_e R)}{R} - p \right\}.$$

474. Cylinder Ratio. Ratio of Expansion. Non-condensing compound engines usually have a cylinder ratio $C=3$ to 4. With condensing engines, the ratio is 4 or 5, increasing with the boiler pressure. In triple engines, the ratios are from 1 : 2.0 : 2.0 up to 1 : 2.5 : 2.5 in stationary practice. With quadruple expansion the ratios are successively from 2.0 to 2.5 : 1.

Tests by Rockwood (22) of a triple engine in which the intermediate cylinder was cut out, permitting of running the high- and low-pressure cylinders as a compound with the high cylinder ratio of 5.7 to 1, give the surprising result that with the same initial pressure and expansive ratio, the compound was more economical than the triple. This was a small engine, with large drop. The pointing out of the fact that the conditions were unduly favorable to the compound as compared with the triple did not explain the excellent economy of the former as compared with all engines of its class. Somewhat later, exceptionally good results were obtained by Barrus (23) with a compound engine having the extraordinary cylinder ratio of 7.2 : 1.0. Thurston, meanwhile, experimented in the same manner as Rockwood, determining, in addition, the economy of the high-pressure and intermediate cylinders when run together as a compound. There were thus two compounds of ratios 3.1 : 1 and 7.13 : 1 and a triple of ratio 1 : 3.1 : 2.3, available for test. The results showed the 7.1 compound to be much better than the 3.1, but less economical than the triple (24). **As the ratio of expansion decreased**, the economy of the intermediate compound closely approached that of the triple; and at a very low ratio it would probably have equaled it. It is a question whether the high economy of these "intermediate compounds" has not been due primarily to the high ratio of expansion which accompanied the high cylinder ratio. The best performances have been reached by compounds and triples alike at ratios of expansion not far from 30. Ordinary compound engines probably have the high-pressure cylinders too large for best economy. This is due to the aim toward overload capacity. As in a simple engine, the less the total ratio of expansion, the greater is the output: but in a compound, the lowest ratio of expansion cannot be less than the cylinder ratio.

Values of R for multiple expansion engines range normally from 12 to 36, usually increasing with the number of expansive stages. Superheat, adequate reheating or jacketing justify the higher values. The use of compound (two-stage) engines is common practice everywhere. For stationary service, since the development of the turbine, the triple, even, is an almost extinct type. The extra mechanical losses necessitated by the triple arrangement often offset the slightly

greater efficiency. The gain by the compound over the simple is so great (where condensing operation is possible) that excepting under peculiarly adverse conditions of fuel cost or load factor the compound must be regarded as the standard form of the reciprocating steam engine using saturated steam.

475. Determination of Low-pressure Cut-off. Tandem Compound. In Fig. 205, let $ABCD$ be a portion of the indicator diagram of the high-pressure cylinder of a tandem receiver engine, release occurring at C . At this point, the whole volume of steam consists of that in the receiver plus that in the high-pressure cylinder. Let the receiver volume be represented by the distance CX . Then the hyperbolic curve XY may represent the expansion of the steam between the states C and D , and by deducting the constant volumes CX , LR , MZ , etc., we obtain the curve CG , representing the expansion of the steam in the two cylinders. For no drop, the pressure at the end of compression into the receiver must be equal to that at C . We thus find the point E , and draw EF , the admission line of the low-pressure cylinder, such that $ac+ad=ae$, etc.; the abscissa of cC being to that of Ed in the same ratio as the respective cylinder volumes. By plotting ED we find the point D at its intersection with CD . A horizontal projection from D to EF gives F . The point F is then the required point of cut-off in the low-pressure cylinder. The diagram $EFSHI$ may be completed, the curve FS being hyperbolic.

476. Analytical Method. Let the volume of high-pressure cylinder be taken as unity, that of the receiver as R , that of the low-pressure cylinder as L . Let x be the fraction of its stroke completed by the low-pressure piston at cut-off, and let p be the pressure at release from the high-pressure cylinder, equal to the receiver pressure at the moment of admission to the low-pressure cylinder. The volume of steam at this moment is $1+R$; at low-pressure cut-off, it is $1+R+xL-x$. If expansion follows the law $pv = PV$, and P be the pressure in the low-pressure cylinder at cut-off,

$$p(1+R) = P(1+R+xL-x), \quad \text{or} \quad P = p \frac{1+R}{1+R+xL-x}.$$

The remaining quantity of steam in the high-pressure cylinder and receiver has the volume $1-x+R$, which, at the end of the stroke, will have been reduced to R . If the pressure at the end of the stroke is to be p , then

$$pR = P(1-x+R) \quad \text{or} \quad P = \frac{pR}{1-x+R}.$$

Combining the two values of P , we find

$$x = \frac{R+1}{RL+1}.$$

477. Cross-compound: Cranks at Right Angles. In Fig. 208, let abC be a portion of the high-pressure diagram, release occurring at C . Communication is now opened with the receiver. Let the receiver volume be laid off as Cd , and let de be a hyperbolic curve. Then the curve Cf , the volume of which at any pressure is Cd less than that of de , represents the path in the high-pressure cylinder. This continues until admission to the low-pressure cylinder occurs at g . The whole volume of steam is now made up of that in the two cylinders and the receiver; the volumes in the cylinders alone are measurable out to fC . In Fig. 209, lay off $hi = iC$ and jk so that $jk + hi$ is equal to the ratio of volumes of low- and high-pressure

cylinder. At the point C of the cycle, the high-pressure crank is at i , the low-pressure crank 90° ahead or behind it. When the high-pressure crank has moved from i to m , the volume of steam in that cylinder is represented by the distance hn , the low-pressure crank is at o and the volume of steam in the low-pressure cylinder is represented by pk . Lay off qr , in Fig. 208, distant from the zero volume line al by an amount equal to $hn + pk$. Draw the horizontal line ts . Lay off $tu = hn$ and $tv = us = pk$. Then u is a point on the high-pressure exhaust line and v is a point on the low-pressure admission line. Similarly, we find corresponding crank positions w and x , and steam volumes hy and zk , and lay off $AB = hy + zk$, $Ac = hy$, $AD = cB = zk$, determining the points c and D . The high-pressure exhaust line

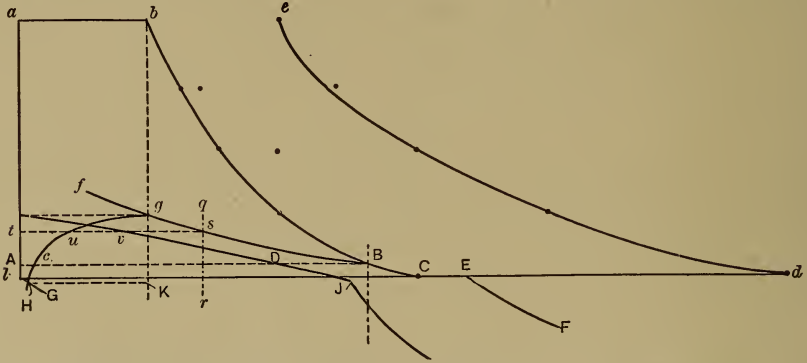

FIG. 208. Arts. 477-479.—Elimination of Drop, Cross-compound Engine.

guc is continued to some distance below l . For no drop, this line must terminate at some point such that compression of steam in the high-pressure cylinder and receiver will make l the final state. At l the high-pressure cylinder steam volume is zero; all the steam is in the receiver. Let lE represent the receiver volume and EF a hyperbolic curve. Draw lG so that at any pressure its volumes are equal to those along EF , minus the constant volume lE . Then H , where lG intersects guc , is the state of the high-pressure cycle at which cut-off occurs in the low-pressure cylinder. By drawing a horizontal line through H to intersect vd , we find the point of cut-off J on the low-pressure diagram. If we regard the initial state as that when admission occurs to the low-pressure cylinder, then at low-pressure cut-off the high-pressure cylinder will have completed the $\frac{KG}{lC}$ proportion of a full stroke.

Modifications of this construction permit of determining the point of cut-off for no drop in triple or quadruple engines with any phase relation of the cranks.

478. Cross-compound Engine: Analytical Method. In this case, the fraction of the stroke completed at low-pressure cut-off is different for the two cylinders. Let X be the proportion of the high-pressure stroke occurring between admission and cut-off in the low-pressure cylinder. Proceeding as before, the volume of the steam at low-pressure admission is $0.5 + R$, and that at low-pressure cut-off is $0.5 - X + R + xL$. The volume of steam in the high-pressure cylinder and the receiver at the end of the high-pressure exhaust stroke is R ; the volume just after low-pressure cut-off occurs is $0.5 - X + R$. The volume at the beginning of exhaust from the high-pressure cylinder is $1 + R$. In Fig. 208, let the pressure at C and l be p ; let that at g be P . Then

to lead to such large economies as in simple engines. Adequately superheated steam has, however, given excellent results, eliminating cylinder condensation so perfectly as to permit of wide ranges of expansion without loss of economy and thus making the efficiency of the engine, within reasonable limits, almost independent of its load. The best test records have been obtained from jacketed engines. A simple engine with highly superheated steam (see Chapter XV) will be nearly as economical as a compound with saturated steam.

483. Binary Vapor Engine. This was originated by Du Tremblay in 1850 (26). The exhaust steam from a cylinder passed through a vessel containing coils filled with ether. The steam being at a temperature of almost 250° F., while the atmospheric boiling point of ether is 94° F., the latter was rapidly vaporized at a considerable pressure, and was then used for performing work in a second cylinder. Assuming the initial temperature of the steam to have been 320° F., and the final temperature of the ether 100° F., the ideal efficiency should thus be increased from

$$\frac{320 - 250}{320 + 460} = 0.09 \text{ to } \frac{320 - 100}{320 + 460} = 0.28,$$

a gain of over 200 per cent. The advantage of the binary vapor principle arises from the low boiling point of the binary fluid. This permits of a lower temperature of heat emission than is possible with water. Binary engines must be run condensing. Since condensing water is generally not available at temperatures below 60° or 70° F., the fluid should be one which may be condensed at these temperatures. Ether satisfies this requirement, and gives, at its initial temperature of, say, 250° F., a working pressure not far from 150 lb. On account of its high boiling point, however, its pressure is less than that of the atmosphere at 70° F., and an air pump is necessary to discharge the condensed vapor from the condenser just as is the case with condensing steam engines. Sulphur dioxide has a much

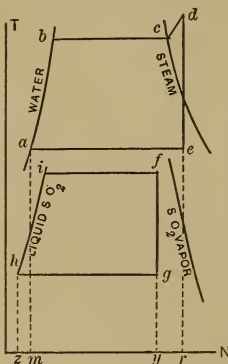

FIG. 217. Art. 483, Prob. 59. — Binary Vapor Engine.

lower boiling point, and may be used without an air pump: but its pressure at 250° would be excessive, and the best results are secured by allowing the steam cylinder to run condensing at a final temperature as low as possible; at 104° F., the pressure of sulphur dioxide is only 90.3 lb. The best steam engines have about this lower temperature limit; the maximum gain due to the use of a binary fluid cannot exceed that corresponding to a reduction of this temperature to about 60° or 70° F., the usual temperature of the available supply of cooling water.

The steam-ether engines of the vessel *Brazil* operated at 43.2 lb. boiler pressure and 7.6 lb. back pressure of ether. The cylinders were of equal size, and the mean effective pressures were 11.6 and 7.1 lb. respectively. The coal consumption was brought down to 2.44 lb. per Ihp.-hr.; a less favorable result than that obtainable from good steam engines of that time. Several attempts have

been made to revive the binary vapor engine on a small scale, the most important recent experiments are those of Josse (27), on a 200-hp. engine using steam at 160 lb. pressure and 200° of superheat, including four cylinders. The first three cylinders constitute an ordinary triple-condensing steam engine, a vacuum of 20 to 25 in. of mercury being maintained in the low-pressure cylinder by the circulation of sulphur dioxide in the coils of a surface condenser. The dioxide then enters the third cylinder at from 120 to 180 lb. pressure and leaves it at about 35 lb. pressure. The best result obtained gave a consumption of 167 B. t. u. per Ihp. per minute, a result scarcely if ever equaled by a high-grade steam engine (Art. 550). The ideal entropy cycle for this engine is shown in Fig. 217, the three steam cylinders being treated as one. The steam diagram is *abcde*, and the heat delivered to the sulphur dioxide vaporizer is *aerm*. This heated the binary liquid along *hi* and vaporized it along *if*, giving the work area *hifg*. The different liquid lines and saturation curves of the two vapors should be noted. The binary vapor principle has been suggested as applicable to gas engines, in which the temperature of the exhaust may exceed 1000° F.

ENGINE TESTS *

484. The Indicator. Two special instruments are of prime importance in measuring the performance of an engine. The first of these is the indicator, one of the secret inventions of Watt (28), which shows the action of the steam in the cylinder. Some conception of the influence of this device on progress in economical engine operation may be formed from the typically bad and good diagrams of Fig. 218. The indicator furnishes a method for computing the mean effective pressure and the horse power of any cylinder.

Figure 219 shows one of the many common forms. Steam is admitted from the engine cylinder through 6 to the lower side of the movable piston 8. The fluctuations of pressure in the cylinder cause this piston to rise or fall to an extent determined by the stiffness of the accurately calibrated spring above it. The piston movements are transmitted through the rod 10 and the parallel motion linkage shown to the pencil 23, where a perfectly vertical movement is produced, in definite proportion to the movement of the piston 8. By means of a cord passing over the sleeves 37, 27, a to-and-fro movement is communicated from the crosshead of the engine to the drum, 24. The movements of the drum, under control of the spring, 31, are made just proportional to those of the piston; so that the coordinates of the diagram traced by the pencil on the paper are pressures and piston movements.

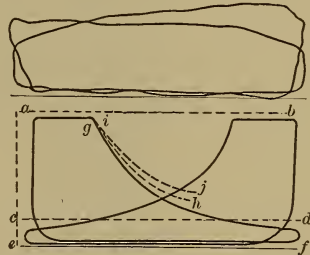

FIG. 218. Arts. 484, 486.— Good and Bad Indicator Diagrams.

485. Special Types. Various modifications are made for special applications. For gas engines, smaller pistons are used on account of the high pressures; springs of various stiffnesses and pistons of various areas are employed to permit of accurately studying the action at different parts of the cycle, safety stops being provided in connection with the lighter springs. The Mathot instrument, for example, gives a continuous record of the *ignition lines only* of a series of suc-

* See *Trans. A. S. M. E.*, XXIV, 713; *Jour. A. S. M. E.*, XXXIV, 11.

cessive gas engine diagrams. "Outside-spring" indicators are a recent type, in which the spring is kept away from the hot steam. The Ripper mean-pressure indicator (29) is a device which shows continuously the mean effective pressure in the cylinder. Instruments are often provided with pneumatic or electrical operating mechanisms, permitting one observer to take exactly simultaneous diagrams from two or more cylinders. Indicators for ammonia compressors must have all internal parts of steel; special forms are also constructed for heavy hy-

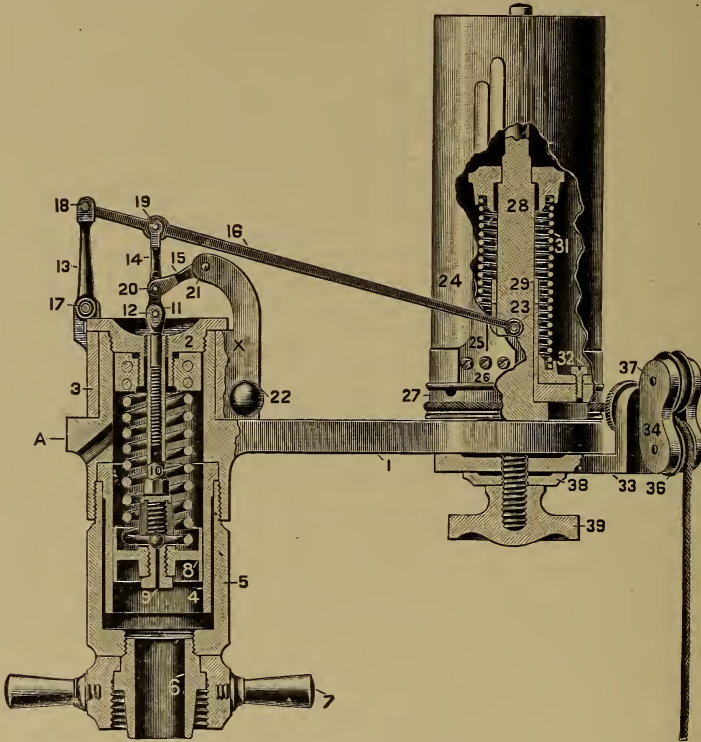

FIG. 219. Art. 484. — Crosby Steam Engine Indicator.

draulic and ordnance pressure measurements. For very high speeds, in which the inertia of the moving parts would distort the diagram, optical indicators are used. These comprise a small mirror which is moved about one axis by the pressure and about another by the piston movement. The path of the beam of light is preserved by photographing it. Indicator practice constitutes an art in itself; for the detailed study of the subject, with the influence of drum reducing motions, methods of calibration, adjustment, piping, etc., reference should be made to such works as those of Carpenter (30) or Low (31). In general, the height of the diagram is made of a convenient dimension by varying the spring to suit the maximum pressure; and accuracy depends upon a just proportion between (*a*) the movements of the drum and the engine piston and (*b*) the movement of the indicator piston and the fluctuations in steam pressure.

486. Measurement of Mean Effective Pressure. This may be accomplished by averaging a large number of equidistant ordinates across the diagram, or, mechanically, by the use of the planimeter (32). In usual practice, the indicator is either piped, with intervening valves, to both ends of the cylinder, in which case a pair of diagrams is obtained, as in Fig. 218, one cycle after the other, representing the action on each side of the piston; or two diagrams are obtained by separate indicators. In order that the diagrams may be complete, the lines *ab*, representing the boiler pressure, *cd*, of atmospheric pressure, and *ef* of vacuum in the condenser, should be drawn, together with the line of zero volume *ea*, determined by measuring the clearance, and the hyperbolic curve *ij*, constructed as in Art. 92. The saturation curve *gh* for the amount of steam actually in the cylinder is sometimes added. As drawn in Fig. 218, the position of the saturation curve indicates that the steam is dry at cut-off—scarcely the usual condition of things.

487. Deductions. By taking a "full-load" card, and then one with the external load wholly removed, the engine overcoming its own frictional resistance only, we at once find the mechanical efficiency, the ratio of power exerted at the shaft to power developed in the cylinder; it is the quotient of the difference of the two diagrams by the former. By measuring the pressure and the volume of the steam at release, and deducting the steam present during compression, we may in a rough way compute the steam consumption per Ihp.-hr., on the assumption that the steam is at this point dry; and, as in Art. 500, by properly estimating the percentage of wetness, we may closely approximate the actual steam consumption.

Some of the applications of the indicator are suggested by the diagrams of Fig. 220. In *a*, we have admission occurring too early; in *b*, too late. Excessively early cut-off is shown in *c*; late cut-off, with excessive terminal drop, in *d*. Figure *e* indicates too early release; the dotted curve would give a larger work area; in *f*, release is late. The bad effect of early compression is indicated in *g*; late compression gives a card like that of *h*, usually causing noisiness. Figure *i* shows exces-

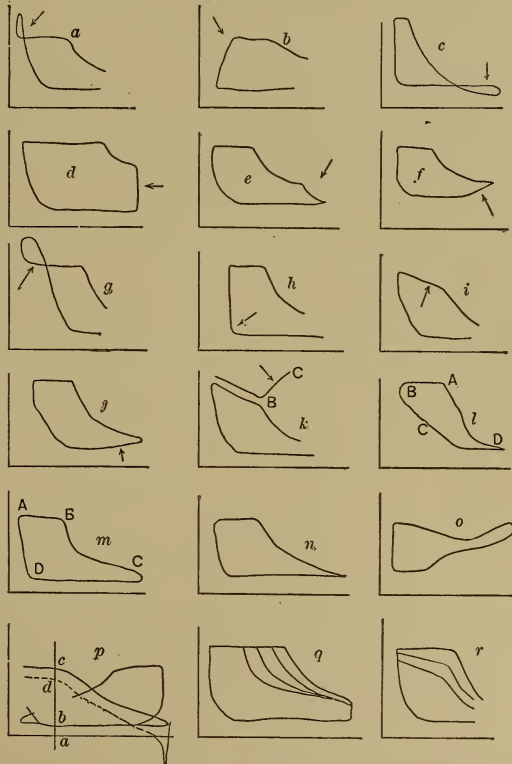

FIG. 220. Art. 487.—Indicator Diagrams and Valve Adjustment.

sive throttling during admission; j indicates excessive resistance during exhaust which may be due to throttling or to a poor vacuum. The effect of a small supply pipe is shown in k , in which the upper line represents a diagram taken with the indicator connected to the steam chest. The abrupt rise of pressure along BC is due to the cutting off of the flow of steam from the steam chest to the cylinder. Figure l shows the form of card taken when the drum is made to derive its motion from the eccentric instead of the crosshead. This is often done in order to study more accurately the conditions near the end of the stroke when the piston moves very slowly, while the eccentric moves more rapidly. Figure m is the corresponding ordinary diagram, and the two diagrams are correspondingly lettered. Figure n is an excellent card from an air compressor; o shows a card from an air pump with excessive port friction, particularly on the suction side. Figure p shows what is called a **stroke card**, the dotted line representing net pressures on the piston, obtained by subtracting the back pressure as at ab from the initial pressure ac , *i.e.* by making $dc = ab$. Figure q shows the effect of varying the point of cut-off; r , that of throttling the supply. Negative loops like that of g must be deducted from the remainder of the diagram in estimating the work done.

488. Measurement of Steam Quality. The second special instrument used in engine testing is the **steam calorimeter**, so called because it determines the percentage of dryness of steam by a series of heat measurements. Carpenter (33) classifies steam calorimeters as follows:

Calorimeters

(a) Condensing	{	Jet { Barrel or tank Continuous Surface { Barrus—Continuous Hoadley Kent
(b) Superheating	{	External—Barrus Internal—Peabody
(c) Direct	{	Separator Chemical

489. Barrel or Tank Calorimeter. The steam is discharged directly into an insulated tank containing cold water. Let W , w be the weights of steam and water respectively, t , t_1 the initial and final temperatures of the water, corresponding to the heat quantities h , h_1 ; and let the steam pressure be P_0 , corresponding to the latent heat L_0 and heat of liquid h_0 , the percentage of dryness being x_0 . The heat lost by the steam is equal to the heat gained by the water; or, the steam and water attaining the same final temperature,

$$W(x_0L_0 + h_0 - h_1) = w(h_1 - h), \text{ whence } x_0 = \frac{h_1(w + W) - wh - Wl_0}{WL_0}.$$

The value of W is determined by weighing the water before and after the mixture. The radiation corrections are large, and any slight error in the value of W

greatly changes the result; this form of calorimeter is therefore seldom used, its average error even under the best conditions ranging from 2 to 4 per cent. Some improvement is possible by causing condensation to become continuous and taking the weights and temperatures at frequent intervals, as in the "Injector" or "Jet Continuous" calorimeter.

490. Surface-condensing Calorimeter. The steam is in this case condensed in a coil; it does not mingle with the water. Let the final temperature of the steam be t_2 , its heat contents h_2 ; then

$$W(x_0L_0 + h_0 - h_2) = w(h_1 - h) \text{ and } x_0 = \frac{wh_1 + Wh_2 - wh - Wh_0}{WL_0}.$$

More accurate measurement of W is possible with this arrangement. In the Hoadley form (34) a propeller wheel was used to agitate the water about the coils; in the Kent instrument, arrangement was made for removing the coil to permit of more accurately determining W . In that of Barrus, the flow was continuous and a series of observations could be made at short intervals.

491. Superheating Calorimeters. The Peabody throttling calorimeter is shown in Fig. 221; steam entering at b through a partially closed valve expands to a lower steady pressure in A and then flows into the atmosphere. Let L_0, h_0, x_0 be the condition at b , and assume the steam to be superheated at A , its temperature being T , t being the temperature corresponding to the pressure p , and the corresponding total heat at saturation H . Then, *the total heat at b equals the total heat at A , or*

$$(x_0L_0 + h_0) = H + k(T - t),$$

where k is the mean specific heat of superheated steam at the pressure p between T and t ; whence

$$x_0 = \frac{H + k(T - t) - h_0}{L_0}.$$

If we assume the pressure in A to be that of the atmosphere, $H = 1150.4$, and superheating is possible only when $x_0L_0 + h_0$ exceeds 1150.4. For each initial pressure, then, there is a corresponding minimum value of x_0 beyond which measurements are impossible; thus, for 200 lb., $L_0 = 843.2$, $h_0 = 354.9$, and x_0 (minimum) is 0.94. Aside from this limitation, the throttling calorimeter is exceedingly accurate if the proper calibrations, corrections, and methods of sampling are adopted. In the Barrus throttling calorimeter, the valve at b is replaced by a diaphragm through which a fine hole is drilled, and the range of x_0 values is increased by mechanically separating some of the moisture. The same advantage is realized in the Barrus superheating calorimeter by initially and externally heating the sample of steam. The

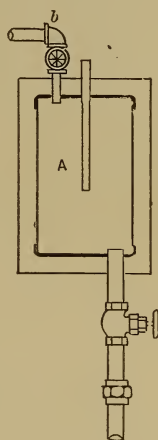

FIG. 221. Art. 491.
— Superheating Calorimeter.

amount of heat thus used is applied in such a way that it may be accurately measured. Let it be called, say, Q per pound. Then

$$x_0 L_0 + h_0 + Q = H + k(T - t), \text{ and } x_0 = \frac{H + k(T - t) - h_0 - Q}{L_0}.$$

492. Separating Calorimeters. The water and steam are mechanically separated and separately weighed. In Fig. 222, steam enters, through 6, the jacketed chamber shown. The water is intercepted by the cup 14, the steam reversing its direction of flow at this point and entering the jacket space 7, 4, whence it is discharged through the small orifice 8. The water accumulates in 3, its quantity being indicated by the gauge glass 10. The quantity of steam flowing is determined by calibration for each reading of the gauge at 9. The instrument is said to be fairly accurate unless the percentage of moisture is very small. The steam may be, of course, run off, condensed, and actually weighed.

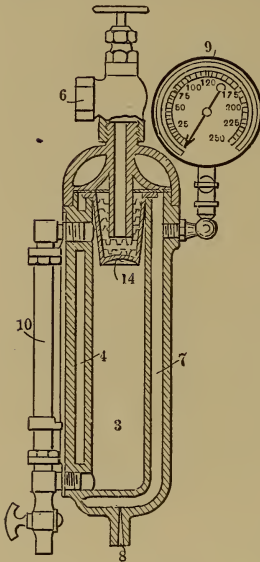

FIG. 222. Art. 492.—Separating Calorimeter.

ing to heat-augmentation to any superheated condition being known, say, as E B. t. u. per pound (1 B. t. u. per minute = 17.59 watts), we have, as in Art. 491,

$$x_0 L_0 + h_0 + E = H + k(T - t), \text{ whence } x_0 = \frac{H + k(T - t) - h_0 - E}{L_0}.$$

495. Engine Trials: Heat Measurement. We may ascertain the heat supplied in the steam engine cycle either by *direct measurement*, or by *adding the heat equivalent of the external work done to the measured amount of heat rejected*. In the former case the amount of water fed to the boiler must be determined, by weighing, measuring, or (in approximate work) by the use of a water meter. The heat absorbed per pound of steam is ascertained from its temperature, quality, and pressure, and the temperature of the water fed to the boiler. In the latter case, the steam leaving the engine is condensed and, in small engines, weighed; or in larger engines, determined by metering or by passing it over a weir. This latter of the two methods of testing has the advantage with small engines of greater

493. Chemical Calorimeter. This depends for its action on the fact that water will dissolve certain salts (*e.g.* sodium chloride) which are insoluble in dry steam.

494. Electric Calorimeter. The Thomas superheating and throttling instrument (35) consists of a small soapstone cylinder in which are embedded coils of German silver wire, constituting an electric heater. This is inserted in a brass case through which flows a current of steam. The electrical energy corresponding

accuracy and of giving accurate results in a test of shorter duration. Where the engine is designed to operate non-condensing, the steam may be condensed for the purposes of the test by passing it over coils exposed to the atmosphere, so that no vacuum is produced by the condensation. If jackets are used, the condensed steam from them must be trapped off and weighed. This water would ordinarily boil away when discharged at atmospheric pressure, so that provision must be made for first cooling it.

496. Heat Balance. By measuring *both* the heat supplied and that rejected, as well as the work done, it is possible to draw up a debit and credit account showing the use made of the heat and the unaccounted for losses. These last are due to the discharge of water vapor by the air pump, to radiation, and to leakage. The weight of steam condensed may easily be four or five per cent less than that of the water fed to the boiler. Let H , h , be the heat contents of the steam and the heat in the boiler feed water respectively; the heat absorbed per pound is then $H - h$. Let Q be the heat contents of the exhausted steam (measured above the feed water temperature) and W the heat equivalent of the work done per pound. Then for a perfect heat balance, $H - h = Q + W$. In practice, W is directly computed from the indicator diagrams; H and Q must be corrected for the quality of steam as determined by the calorimeter or otherwise.

The heat charged to the engine is measured *from* the ideal feed-water temperature corresponding with the pressure of the atmosphere or condenser *to* the condition of steam at the throttle: that is, it is (in general symbols),

$$R = Q(H - h_o), \quad \text{B. t. u. per Ihp. hr.},$$

where Q represents the dry steam consumption in lb. per Ihp. hr. Then $2545 \div R$ is the *thermal efficiency* $= E$. Let H_o be the total heat above 32° after adiabatic expansion in the Clausius cycle: then the ideal efficiency is

$$E_I = \frac{H - H_o}{H - h_o},$$

and the "efficiency ratio" or relative efficiency is

$$E_R = \frac{E}{E_I} = \frac{2545}{Q(H - H_o)}.$$

The efficiency ratio referred to the Carnot cycle is correspondingly

$$E_C = \frac{2545T}{Q(H - h_o)(T - t)},$$

where T and t are, respectively, the absolute temperatures at the throttle and corresponding with atmospheric or condenser pressure.

In working up a heat balance, it is convenient to measure all heat

quantities above 32° . The gross heat charged to the engine is then HQ , less any transmission losses between boiler and engine. If the engine runs condensing, and Q_1 lb. of condenser water circulated rise from t_1° to t_2° F., the heat rejected to the circulating water is $Q_1(t_2 - t_1)$ B. t. u. There are also rejected, in the condensed steam, Qh_3 B. t. u., where h_3 is the heat of liquid corresponding with the temperature t_3 of the condensed steam. (Note that $t_3 = t_2$ in *jet* condensing engines.) Some of the heat thus rejected may, however, be returned to the boiler, and should then be credited, the amount of credit being the sum of the weights returned each multiplied by the respective heat of liquid. Any steam condensed in the jackets is charged to the engine, but the heat rejected from the jackets (usually returned to the boiler) is then credited as Q_2h where Q_2 is the weight of steam condensed and h the heat of liquid corresponding with its pressure (usually the throttle pressure).

497. Checks; Codes. Where engines are used to drive electrical generators the measurement of the electrical energy gives a close check on the computation of indicated horse power. Let G = generator output in kilowatts, E_G = generator efficiency, E_m = mechanical efficiency of the unit, H = Ihp. of engine: then $1.34G = HE_G E_m$. In locomotive trials a similar check is obtained by comparison of the drawbar pull and speed (36). In turbines, the indicator cannot be employed; measurement of the mechanical power exerted at the shaft is effected by the use of the friction brake. Standard codes for the testing of pumping engines (37), and of steam engines generally (38), have been developed by the American Society of Mechanical Engineers.

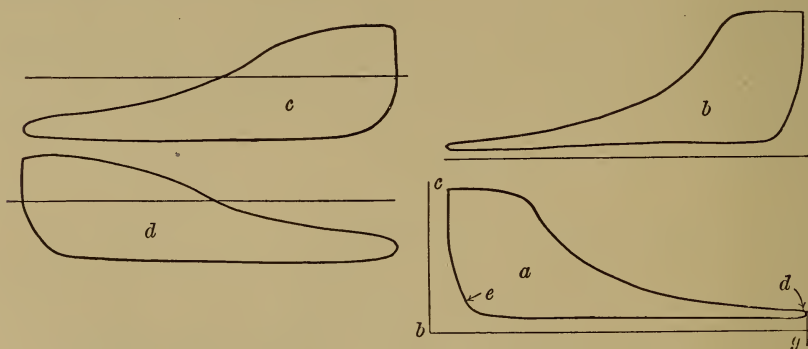

FIG. 224. Arts. 498, 499, 500.—Indicator Cards from Compound Engine.

498. Example of an Engine Test.* Figure 224, from Hall (39), gives the indicator diagrams from a 30 and 56 by 72-in. compound engine at 58 r. p. m. The piston rods were $4\frac{7}{8}$ and $5\frac{1}{4}$ in. diameter. The boiler

* Values from steam tables, used in this article, do not precisely agree with those given on pp. 287, 288.

pressure was 124.0 lb. gauge: the pressure in the steam pipe near the engine, 122.0 lb. The temperature of jacket discharge was 338° F. The conditions during the calorimetric test of the inlet steam were $P_0 = 122.08$ lb. gauge, $T = 302.1^\circ$ F. (Art. 491), pressure in calorimeter body (Fig. 221), 11.36 lb. (gauge). The net weight of boiler feed water in 12 hours was 231,861.7 lb.; the weight of water drained from the jackets, 15,369.7 lb.

From the cards, the mean effective pressures were 44.26 and 13.295 lb. respectively; and as the average net piston areas were 697.53 and 2452.19 square inches respectively, the total piston pressures were $44.26 \times 697.53 = 30872.7$ and $13.295 \times 2452.19 = 32601.9$ lb. respectively. These were applied through a distance of

$$\frac{7\frac{1}{2}}{12} \times 2 \times 58 = 696 \text{ feet per minute;}$$

whence the indicated horse power was

$$\frac{(30872.7 + 32601.9) \times 696}{33000} = 1338.62.$$

From Art. 491, $x_0 L_0 + h_0 = H + k(T - t)$, or in this case, $866.5x + 322.47 = 1155.84 + 0.48^* (302.1 - 242.3)$ whence $x_0 = 0.995$. The weight of cylinder feed was $231,861.7 - 15,369.7 = 216,492.0$ lb. At its pressure of 136.7 lb. absolute, $L = 866.5$, $h = 322.4$. For the ascertained dryness, the total heat per pound, above 32°, is $322.4 + (0.995 \times 866.5) = 1184.5$ B. t. u. The heat left in the steam at discharge from the condenser (at 114° F.) was 82 B. t. u.; the net heat absorbed per pound of cylinder feed was then $1184.5 - 82.0 = 1102.5$; for the total weight of cylinder feed it was $1102.5 \times 216,492 = 238,682,430$ B. t. u. The total heat in one pound of jacket steam was also 1184.5 B. t. u. This was discharged at 338° F. ($h = 308.8$), whence the heat utilized in the jackets was $1184.5 - 308.8 = 875.7$ B. t. u. (The heat discharged from both jackets and cylinders was transferred to the boiler feed water, the former at 338°, the latter at 114° F.) The supply of heat to the jackets was then $875.7 \times 15,369.7 = 13,459,246.29$ B. t. u: the total to cylinders and jackets was this quantity plus 238,682,430 B. t. u., or 252,141,676.29 B. t. u. Dividing this by 60×12 we have 350,196.77 B. t. u. supplied per minute.

499. Statement of Results. We have the following:

- (a) Pounds of steam per Ihp.-hr. = $231,861.7 \div 12 \div 1338.62 = 14.43$.
 (This is the most common measure of efficiency, but is wholly unsatisfactory when superheated steam is used.)

* Value taken for the specific heat of superheated steam.

(b) Pounds of *dry* steam per Ihp.-hr. = $14.43 \times 0.995^* = 14.36$.

(c) Heat consumed per Ihp. per minute = $350,196.77 \div 1338.62 = 261.61$
B. t. u.

(d) Thermal efficiency = $\frac{33900}{78} \div 261.61 = 0.1621$.

(e) Work per pound of steam = $\frac{252,141,676.29}{231,861.7} \times 0.1621 = 176$ B. t. u.

(f) Carnot efficiency = $\frac{351.22 - 114}{351.22 + 459.6} = 0.293$.

(g) Clausius efficiency (Art. 409), with dry steam,

$$\frac{(351.22 - 114) \left(1 + \frac{866.5}{810.82} \right) - 573.6 \log_e \frac{810.82}{573.6}}{351.22 - 114 + 866.5} = 0.265.$$

(h) Ratio of (d) \div (g) = $0.1621 \div 0.265 = 0.61$.

500. Steam Consumption from Diagram. The inaccuracy of such estimates will be shown. In the high-pressure cards, Fig. 224, the clearance space at each end of the cylinder was 0.932 cu. ft. The piston displacement per stroke on the side opposite the rod was $706.86 \times 72 \div 1728 = 29.453$ cu. ft.; the cylinder volume on this side was $29.453 + 0.932 = 30.385$ cu. ft. The length of the corresponding card (*a*) is 3.79 in.; the clearance line *bc* is then drawn distant from the admission line

$$3.79 \times \frac{0.932}{29.453} = 0.117 \text{ in.}$$

At *d*, on the release line, the volume of steam is 30.385 cu. ft., and its pressure is 31.2 lb. absolute. From the steam table, the weight of a cubic foot of steam at this pressure is 0.076362 lb.; whence the weight of steam present, assumed dry, is $0.076362 \times 30.385 = 2.3203$ lb. At a point just after the beginning of compression, point *e*, the volume of steam expressed as a fraction of the stroke plus the clearance equivalent is $0.517 \div 3.907 = 0.1321$, 3.907 being the length *bg* in inches. The actual volume of steam at *e* is then $0.1321 \times 30.385 = 4.038$ cu. ft., and its pressure is 28.3 lb. absolute, at which the specific weight is 0.069683 lb. The weight present at *e* is then $4.038 \times 0.069683 = 0.280$ lb. The net weight of steam used per stroke is $2.3203 - 0.280 = 2.0403$ lb., or, per hour, $2.0403 \times 58 \times 60 = 7090$ lb., for this end of the cylinder only. For the other end, the weight, similarly obtained, is 7050 lb.; the total weight is then 14,140 lb. The horse power developed being 1339, the cylinder feed per Ihp.-hr. from high-pressure diagrams is 10.6 lb., or 26 per cent less than that which the test shows. The same process may be applied to the low-pressure diagrams. It is best to take the points *d* and *e* just before the beginning of release and after the beginning of compression respec-

* The factor 0.995 does not precisely measure the ratio of energy in the actual steam to that in the corresponding weight of dry steam, but the correction is usually made in this way.

tively. The method is widely approximate, but may give results of some value in the absence of a standard trial (Arts. 448, 440).

501. General Expression. In Fig. 224a, let $\frac{v}{L} = B, \frac{V}{L} = D$. Let the cylinder area be A sq. in., the stroke S ft., the clearance $d = m(L-d) = mAS$: and let the speed be n r. p. m. The horse power of the double-acting engine is

$$\text{H.P.} = \frac{2p_m A S n}{33,000},$$

for p_m lbs. mean effective pressure per square inch. The weight of steam used per stroke, in pounds, is

$$W = \frac{BAS(1+m)}{144xv_o} - \frac{DAS(1+m)}{144XV_o} = \frac{AS}{144} \left(1+m\right) \left(\frac{B}{xv_o} - \frac{D}{XV_o}\right),$$

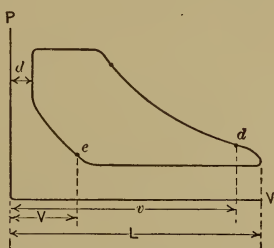

FIG. 224a. Art. 501.—Steam Consumption from Diagram.

where v_o and V_o are the specific volumes of dry steam and x and X are the dryness of the actual steam, at d and e respectively. Making $X = x = 1.0$, we find (from the indicator diagrams alone) the weight of steam consumed per Ihp. hour to be in pounds,

$$\frac{120nW}{\text{H.P.}} = \frac{13,750(1+m)}{p_m} \left(\frac{B}{v_o} - \frac{D}{V_o}\right).$$

In applying this to compound engines, p_m must be taken as the total equivalent mean effective pressure “referred to” to the cylinder of area A (Art. 472).

For the conditions of Art. 500, $p_m = 44.26 + \left(\frac{56^2}{30^2} \times 13.295\right) = 90.36$, and the steam rate is

$$13,750 \left(\frac{1.0317}{90.36}\right) \left(\frac{30.385}{30.385 \times 13.24} - \frac{4.038}{30.385 \times 14.53}\right) = 10.4 \text{ lb.}$$

502. Measurement of Rejected Heat. A common example is in tests in which the steam is condensed by a jet condenser (Art. 584). In a test cited by Ewing (40), the heat absorbed per revolution measured above the temperature of the boiler feed was 1551 B. t. u.; that converted into work was 225 B. t. u. The exhaust steam was mingled with the condensing water, a combined weight of 51.108 lb. being found per revolution. The temperature of the entering water was 50° F., that of the discharged mixture was 73.4° F., and the cylinder feed amounted to 1.208 lb. per revolution. The temperature of the boiler feed water was 59° F. We may compute the injection water as $51.108 - 1.208 = 49.9$ lb. and the heat absorbed by it as approximately $49.9(73.4 - 50) = 1167$ B. t. u. The 1.208 lb. of feed were discharged at 73.4°, whereas the boiler feed was at 59°; a heat rejection of $73.4 - 59 = 14.4^\circ$ occurred, or $14.4 \times 1.208 = 17.4$

B. t. u. The total heat rejection was then $1167 + 17.4 = 1184.4$ B. t. u., to which we must add 47 B. t. u. from the jackets, giving a total of 1231.4 B. t. u. Adding this to the work done, we have $1231.4 + 225 = 1456.4$ B. t. u. accounted for of the total 1551 B. t. u. supplied; the discrepancy is over 6 per cent.

When surface condensers are used, the temperatures of discharge of the condensed steam and the condenser water are different and the weight of water is ascertained directly. In other respects the computation would be as given.*

503. Statements of Efficiency. Engines are sometimes rated on the basis of fuel consumption. The **duty** is the number of foot-pounds of work done in the cylinder per 100 pounds of coal burned (sometimes—and preferably—the number of foot-pounds of work *per 1,000,000 B. t. u. consumed at coal*). The **efficiency of the plant** is the quotient of the heat converted into work per pound of coal, by the heat units contained in the pound of coal. In the test in Art. 498, the coal consumption per Ihp.-hr. was $2068.84 \div 1338.62 = 1.54$ lb. In some cases, all statements are based on the *brake horse power* instead of the *indicated horse power*. The ratio of the two is of course the **mechanical efficiency**. It may be noted that the engine is charged with steam, not at boiler pressure, but at the pressure in the steam pipe. The difference between the two pressures and qualities represents a loss which may be considered as dependent upon the **transmissive efficiency**. The plant efficiency is obviously the product of the efficiencies of boiler (Art. 574), transmission, and engine.

504. Measurement of Heat Transfers: Hirn's Analysis. In the refined methods of studying steam engine performance developed by Hirn (41), and expounded by Dwelshauvers-Dery (42), the heat absorbed and that rejected are both measured. During any path of the cycle, the heat interchange between fluid and walls is computed from the change in internal energy, the heat externally supplied or discharged, and the external work done.

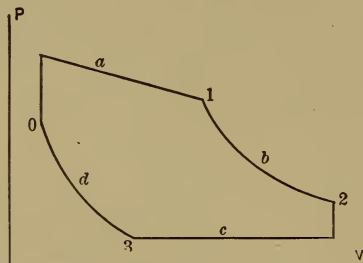

FIG. 225. Art. 504.—Hirn's Analysis.

The internal energy of steam is, in general symbols, $h + xr$. The heat received being Q , and the heat lost by radiation Q' , we have the general form

$$Q_{12} = Q'_{12} + E_2 - E_1 + W_{12} = Q_{12} + w_2(h_2 + x_2r_2) - w_1(h_1 + x_1r_1) + W_{12},$$

where the path is, for example, from 1 to 2, and the weight of steam increases from w_1 to w_2 . Applying such equations to the cycle, Fig. 225, made up of the four

* It is most logical to charge the engine with the heat measured above the temperature of heat rejection. This, in Fig. 182, for example, makes the efficiency $\frac{debc}{idbeZ}$, rather than $\frac{debc}{YXebZ}$, the ordinate YX representing the feed-water temperature.

operations 01, 12, 23, 30, we have, M_0 denoting the weight of clearance steam and M that of cylinder feed, per stroke, in pounds.

$$\begin{aligned} E_0 &= M_0(h_0 + x_0 r_0); & E_2 &= (M_0 + M)(h_2 + x_2 r_2); \\ E_1 &= (M_0 + M)(h_1 + x_1 r_1); & E_3 &= M_0(h_3 + x_3 r_3). \end{aligned}$$

Let Q_a, Q_b, Q_c, Q_d , represent amounts of heat transferred to the walls along the paths a, b, c, d .

Consider the path a . Let the heat supplied by the incoming steam be Q . Then

$$Q - Q_a = W_a + (E_1 - E_0).$$

Along the path b , $-Q_b = W_b + (E_2 - E_1)$; along d , $-Q_d = -W_d + (E_0 - E_3)$.

Along c , heat is carried away by the discharged steam and by the cooling water. Let G denote the weight of cooling water per stroke, h_5 and h_4 its final and initial heat contents, and h_6 the heat contents of the discharged steam. The heat rejected by the fluid per stroke is then $G(h_5 - h_4) + Mh_6$. Then $-Q_c - G(h_5 - h_4) - Mh_6 = -W_c + (E_3 - E_2)$, and $Q_c = -G(h_5 - h_4) - Mh_6 + W_c - (E_3 - E_2)$.

Values for the h and r quantities are obtained from the steam table for the pressures shown by the indicator diagram. The diagram gives also the work quantities along each of the four "paths." The conditions of the test give Q, G, h_5, h_6, h_4 , and M . The remaining unknown quantities are M_0 and the drynesses. M_0 is found by assuming $x_3 = 1.0$ (see Art. 500). Then the dryness at any of the remaining points 0, 1, 2, may be found by writing

$$x = \frac{v}{wv_0},$$

where v is the volume shown by the indicator diagram, v_0 is the specific volume of dry steam and w is the weight of steam present, at the point in question. The quantity w will be equal to M_0 or $(M + M_0)$ as the case may be.

505. Graphical Representation. In Fig. 226, from the base line xy , we may lay off the areas $ocfs$ representing heat lost during admission, $smba$ showing heat gained during expansion, mhr showing heat gained during release, and $oakr$ showing heat lost during compression. If there were no radiation losses from the walls to the atmosphere, the areas above the line xy would just equal those below it. Any excess in upper areas represents radiation losses. Ignoring these losses, Hirn found by comparing the work done with the value of $Q - Mh_6 - G(h_5 - h_4)$ an approximate value for the **mechanical equivalent of heat** (Art. 32).

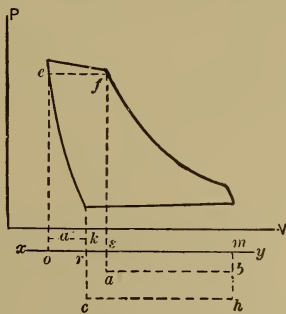

FIG. 226. Art. 505.—Heat Transfers.

Analytically, if Q_r denote the loss by radiation, its value is the algebraic sum of Q_a, Q_b, Q_c, Q_d . If the heat Q_j be supplied by a steam jacket, then $Q_r = Q_j + \Sigma Q_a, b, c, d$. The heat transfer during release, Q_c , regarded by Hirn as in a special sense a measure of wastefulness of the walls, may be expressed as $Q_r - Q_j - \Sigma Q_a, b, a$. In a non-condensing engine, Q_r can be determined only by direct experiment.

505a. Testing of Regulation. The "regulation" of a steam engine refers to its variations in speed. In most applications uniformity of rotation is important. This is particularly the case when engines drive electric generators, and the momen-

tary or periodic variations in speed must be kept small regardless of fluctuations in initial pressure, back pressure, load or ratio of expansion. This is accomplished by using a sensitive governor and a suitably heavy fly-wheel. Regulation cannot be studied by unaided observation with a revolution counter or by an ordinary recording instrument. An accurate indicating tachometer or some special optical device must be employed (*Trans. A. S. M. E.*, XXIV, 742).

TYPES OF STEAM ENGINE

506. Special Engines. We need not consider the commercially unimportant class of engines using vapors other than steam, those experimental engines built for educational institutions which belong to no special type (43), engines of novel and limited application like those employed on motor cars (44), nor the "fireless" or stored hot-water steam engines occasionally employed for locomotion (45).

507. Classification of Engines. Commercially important types may be condensing or non-condensing. They are classified as right-hand or left-hand, according as the fly wheel is on the right or left side of the center line of the cylinder, as viewed from the back cylinder head. They may be simple or multiple-expan-

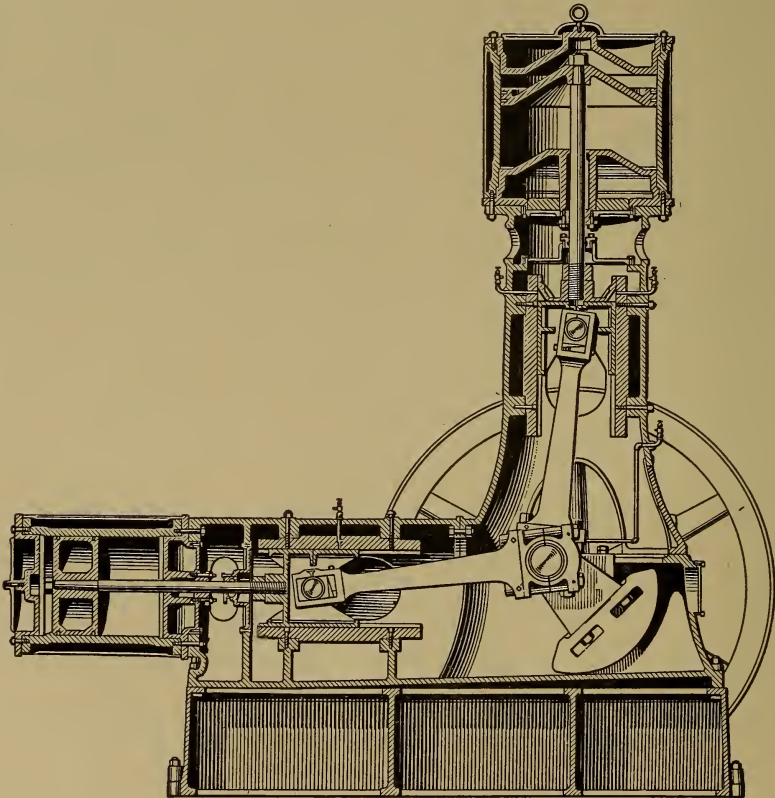

FIG. 228. Art. 507. — Angle-Compound Engine. (American Ball Engine Company.)

sion, with all the successive stages and cylinder arrangements made possible in the latter case. They may be *single-acting* or *double-acting*; the latter is the far more usual arrangement. They may be *rotative* or *non-rotative*. The *direct-acting* pumping engine is an example of the latter type; the work done consists in a rectilinear impulse at the water cylinders. In the *duplex engine*, simple cylinders are used side by side. The terms *horizontal*, *vertical*, and *inclined* refer to the positions of the center lines of the cylinders. The horizontal engine, as in Figs. 186 and 229, is mostly used in land practice; the vertical engine is most common at

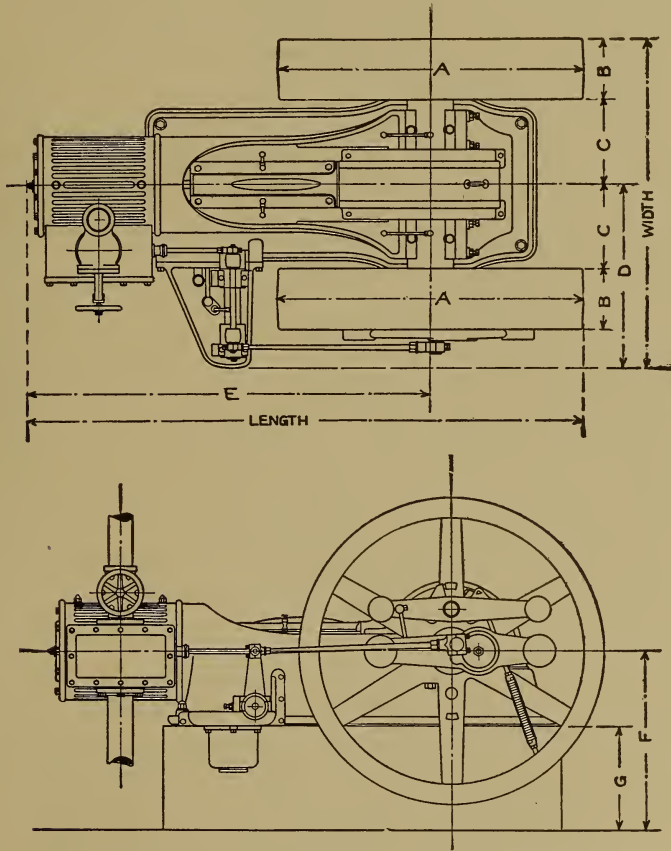

FIG. 229. Art. 507.— Automatic Engine. (American Ball Engine Company.)

sea. Cross-compound vertical engines are often direct-connected to electric generators. Vertical engines have occasionally been built with the cylinder below the shaft. This type, with the inclined engine, is now rarely used. Inclined engines have been built with *oscillating cylinders*, the use of a crosshead and connecting rod being avoided by mounting the cylinder on trunnions, through which the steam was admitted and exhausted. Figure 228 shows a section of

the interesting **angle-compound**, in which a horizontal high-pressure cylinder exhausts into a vertical low-pressure cylinder. A different type of engine, but with a similar structural arrangement, has been used in some of the largest power stations.

Engines are **locomotive**, **stationary**, or **marine**. The last belong in a class by themselves, and will not be illustrated here; their capacity ranges up to that of our largest stationary power plants. Stationary engines are further classed as **pumping engines**, **mill engines**, **power plant engines**, etc. They may be further grouped according to the method of absorbing the power, as **belted**, **direct-connected**, **rope driven**, etc. An engine directly driving an **air compressor** is shown in Fig. 86. "Rolling mill engines" undergo enormous variations in load, and must have a correspondingly massive (**tangye**) frame. Power plant engines generally must be subjected to heavy load variations; their frames are accordingly usually either **tangye** or **semi-tangye**. Mill engines operate at steadier loads, and have frequently been built with light **girder** frames. Modern high steam pressures have, however, led to the general discontinuance of this frame in favor of the **semi-tangye**.

A **slow-speed** engine may run at any speed up to 125 r.p.m. From 125 to 200 r.p.m. may be regarded as **medium speed**. Speeds above 200 r.p.m. are regarded as **high**. Certain types of engine are adapted only for certain speed ranges; the ordinary slide-valve engine, shown in Fig. 186, may be operated at almost any speed. For large units, speeds range usually from 80 to 100 r.p.m. The higher-speed engines are considered mechanically less reliable, and their valves do not lend themselves to quite as economical a distribution of steam. An important class of medium-speed engines has, however, been introduced, in which the independent valve action of the Corliss type has been retained, and the promptness of cut-off only attainable by a releasing gear has been approximated. In some cheap high-speed engines governing is effected simply but uneconomically by **throttling** the steam supply. Such engines may have shallow continuous frames or the **sub-base**, as in Fig. 229, which represents the large class of **automatic high-speed engines** in which regulation is effected by automatically varying the point of cut-off. Figure 230 shows three sets of indicator diagrams from a compound engine of this type, running non-condensing at various loads. Some of the irregularities of these diagrams are without doubt due to indicator inertia; but they should be carefully compared with those showing the steam distribution with a slow-speed



FIG. 230. Art. 507, Prob. 30.—Indicator Cards from Automatic Engine.

which the four events of the stroke may be independently adjusted, and this type is often used at moderately high speeds. Sharpness of cut-off is usually obtainable only with a releasing gear, in which the mechanism operating the valves is disconnected, and the steam valve is automatically and instantaneously closed. This feature distinguishes the Corliss type, most commonly used in high-grade mill and power plant service. With the releasing gear, usual speeds seldom exceed 100 r. p. m. The valve in a Corliss engine is cylindrical, and extends across the cylinder. Some details of the mechanism are shown in Fig. 231. In very large engines, the releasing principle is sometimes retained, but with poppet or other forms of valve. Figure 232 shows the parts of a typical Corliss engine with semi-tangye frame.

507a. The Stumpf Engine. Remarkable reductions in cylinder loss have been effected by the unidirectional-flow piston-exhaust engine of Stumpf, shown in Fig. 231a. The piston itself acts as an exhaust valve by uncovering slots in the barrel of the cylinder at $\frac{3}{10}$ strike. The jacketed heads form steam chests for the poppet admission valves. The piston is about half as long as the cylinder. The advantages of the engine are, very slight piston leakage, no special exhaust valve, ample exhaust ports, low clearance ($1\frac{1}{2}$ to 2 per cent) and reduced cylinder condensation. This last is due to the continuous flow of steam from ends to center of the cylinder, which keeps the cooled and expanded steam from sweeping over the heads. (The steam in an engine cylinder is by no means in a condition of thermal equilibrium.) The condensation is so small that very large ratios of expansion are employed, and the simple engine with either saturated or superheated steam seems to give an efficiency about equal to that attained by a triple expansion engine of the ordinary type. Compression is necessarily excessive; so much so that when the engine is used non-condensing a special piston valve, working in

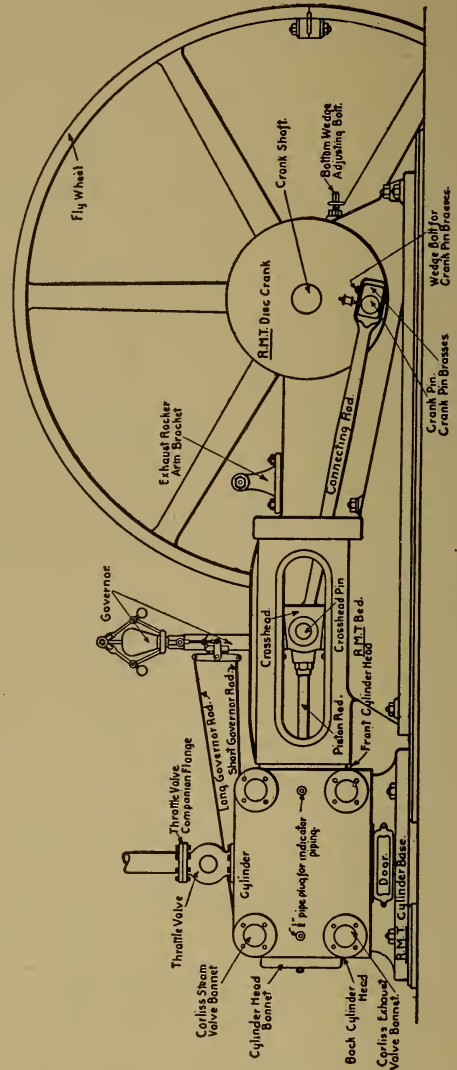

Fig. 232. Art. 507. — Murray Corliss Engine.

the piston, is used to prolong the exhaust period during part of the return stroke. Some of the advantages are thereby sacrificed: this modification is not necessary on condensing engines.

The device has been applied to locomotives on the Prussian state railways (*Engineering Magazine*, March, 1912). The cylinders are of excessive lengths: a special valve gear, highly economical in power consumption, has been developed. The early compression (no supplementary exhaust valve being used) requires large clearance: but it is claimed that with a concave-ended hollow piston the wall surface of the clearance space (which influences the loss) is from 40 to 60 per cent less than that in an ordinary locomotive cylinder. Any initial condensation is automatically

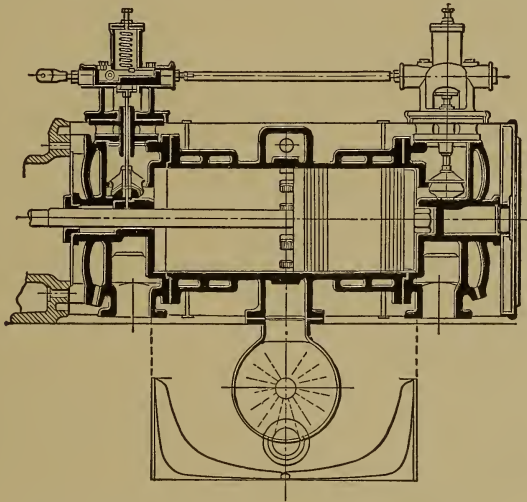

FIG. 231a. Art. 507a.—The Stumpf Engine.

discharged through holes in the cylinder wall, so that it ceases to be a factor in producing further condensation.

508. The Steam Power Plant. Figure 233, from Heck (46), is introduced at this point to give a conception of the various elements composing, with the engine, the complete steam plant. Fuel is burned on the grate 1; the gases from the fire follow the path denoted by the arrows, and pass the damper 4 to the chimney 5. Water enters, from the pump IV, the boiler through 29, and is evaporated, the steam passing through 8 to the engine. The exhaust steam from the engine goes through 18 to the condenser III, to which water is brought through 21. Steam to drive the condenser pump comes from 26. Its exhaust, with that of the feed pump 31, passes to the condenser through 27. The condensed steam and warmed water pass out through 23, and should, if possible, be used as a source of supply for the boiler feed. The free exhaust pipe 19 is used in case of breakdown at the condenser.

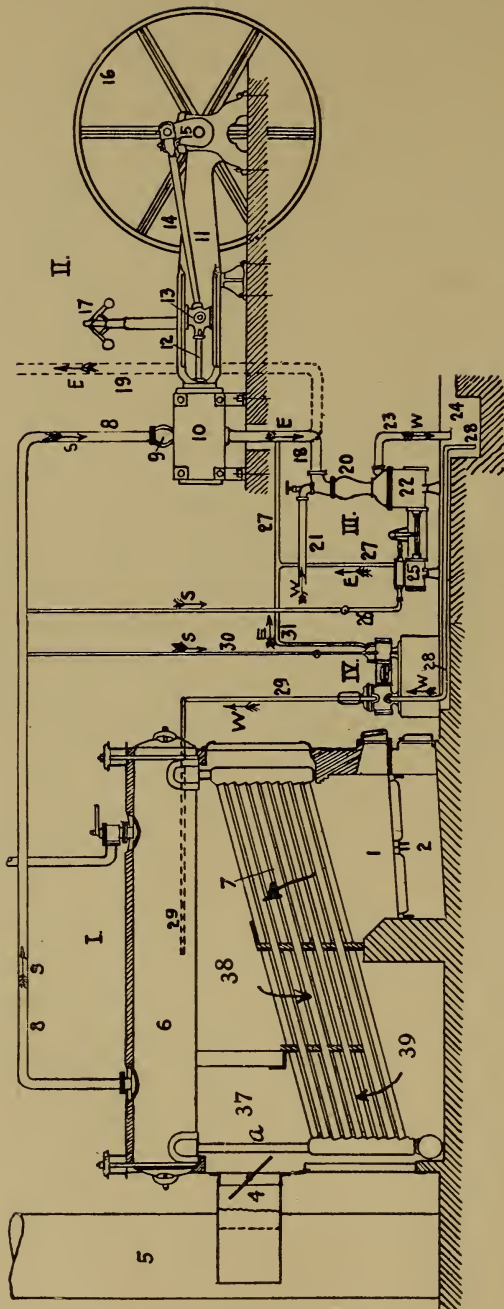

FIG. 233. Arts. 508, 508, 580, 584, Prob. 56. — The Steam Power Plant. (From "The Steam Engine," by R. C. H. Heck.)

509. The Locomotive.

This is an entire power plant, made portable. Figure 234 shows a typical modern form. The engine consists of two horizontal double acting cylinders coupled to the ends of the same axle at right angles. These are located under the front end of the boiler, which is of the type described in Art. 563. A pair of heavy frames supports the boiler, the load being carried on the axles by means of an intervening "spring rigging." The stack is necessarily short, so that artificial draft is provided by means of an expanding nozzle in the "smoke box," through which the exhaust steam passes; live steam may be used when necessary to supplement this. The engines are non-condensing, but superheating and heating of feed water, particularly the former, are being introduced extensively. The water is carried in an auxiliary tender, excepting in light locomotives, in which a "saddle" tank may be built over the boiler.

The ability of a locomotive to start a load depends upon the force which it can exert at the rim of the driving wheel. If d is the cylinder diameter in inches, L the stroke in feet, and p the maximum mean effective pressure of the steam per square inch, the work done per revolution by two equal cylinders is $\pi d^2 L p$. Assume

this work to be transmitted to the point of contact between wheel and rail without loss, and that the diameter of the wheel is D feet, then the tractive power, the force exerted at the rim of the wheel, is $\pi d^2 L p \div \pi D = \frac{d^2 L p}{D}$.

The value of p , with such valve gears as are employed on locomotives, may be taken at 80 to 85 per cent of the boiler pressure. The actual tractive power, and the pull on the drawbar, are reduced by the friction of the mechanism; the latter from 5 to 15 per cent. Under ordinary conditions of rail, the wheels will slip when the tractive power exceeds 0.22 to 0.25 the total weight carried by the driving wheels. This fraction of the total weight is called the **adhesion**, and it is useless to make the tractive power greater. In locomotives of certain types, a "traction increaser" is sometimes used. This is a device for shifting some of the weight of the machine from trailer wheels to driving wheels. The weight on the drivers and the adhesion are thereby increased. The engine man, upon ap-

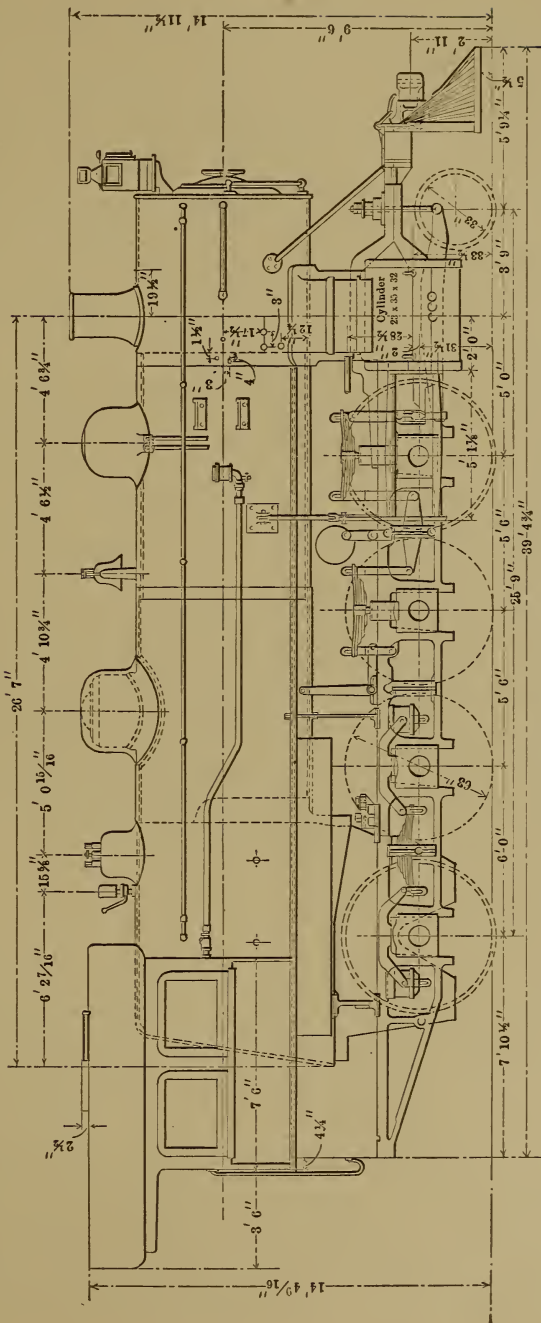

FIG. 234. Art. 509. — Consolidation Locomotive. (American Locomotive Company.)

proaching a heavy grade, may utilize a higher boiler pressure or a later cut-off than would otherwise be useful.

510. Compounding. Mallet compounded the two cylinders as early as 1876. The steam pipe between the cylinders wound through the smoke box, thus becoming a reheating receiver. Mallet also proposed the use of a pair of tandem compound cylinders on each side. The Baldwin type of compound has two cylinders on each side, the high pressure being above the low pressure. Webb has used two ordinary outside cylinders as high-pressure elements, with a very large low-pressure cylinder placed under the boiler between the wheels. In the Cole compound, two outside low-pressure cylinders receive steam from two high-pressure inside cylinders. The former are connected to crank pins, as in ordinary practice: the latter drive a forward driving axle, involving the use of a **crank axle**. The four crank efforts differ in phase by 90° . This causes a very regular rotative impulse, whence the name **balanced compound**. Inside cylinders, with crank axles, are almost exclusively used, even with simple engines, in Europe: two-cylinder compounds with both cylinders inside have been employed. The use of the crank axle has been complicated in some locomotives with a splitting of the connecting rod from the inside cylinders to cause it to clear the forward axle. Greater simplicity follows the standard method of coupling the inside cylinders to the forward axle.

511. Locomotive Economy. The aim in locomotive design is not the greatest economy of steam, but the installation of the greatest possible power-producing capacity in a definitely limited space. Notwithstanding this, locomotives have shown very fair efficiencies. This is largely due to the small excess air supply arising from the high rate of fuel consumption per square foot of grate (Art. 564). The locomotive's normal load is what would be considered, in stationary practice, an extreme overload. Its mechanical efficiency is therefore high. For the most complete data on locomotive trials, the Pennsylvania Railroad Report (47) should be consulted. The American Society of Mechanical Engineers has published a code (48); Reeve has worked out the heat interchange in a specimen test by Hirn's analysis (49). (See Art. 554.)

(1) D. K. Clark, *Railway Machinery*. (2) Isherwood, *Experimental Researches in Steam Engineering*, 1863. (3) *De la condensation de la vapeur*, etc., *Ann. des mines*, 1877. (4) *Bull. de la Soc. Indust. de Mulhouse*, 1855, et seq. (5) *Proc. Inst. Civ. Eng.*, CXXXI. (6) Peabody, *Thermodynamics*, 1907, 233. (7) *Min. Proc. Inst. C. E.*, March, 1888; April, 1893. (8) *Op. cit.* (9) *Engine Tests*, G. H. Barrus. (10) *The Steam Engine*, 1892, p. 190. (11) *The Steam Engine*, 1905, 109, 119, 120. (12) *Proc. Inst. Mech. Eng.*, 1889, 1892, 1895. (13) Ripper, *Steam Engine Theory and Practice*, 1905, p. 167. (14) Ripper, *op. cit.*, p. 149. (15) *Trans. A. S. M. E.*, XXVIII, 10. (16) For a discussion of the interpretation of the Boulvin diagram, see Berry, *The Temperature-Entropy Diagram*, 1905. (17) *Proc. Inst. Mech. Eng.*, January, 1895, p. 132. (18) *The Steam Engine*, 1906. (19) *Trans. A. S. M. E.*, XV. (20) *Ibid.*, XIII, 647. (21) *Ibid.*, XIX, 189. (22) *Ibid.*, loc. cit. (23) *Ibid.*, XXV, 482, 483, 490, 492. (24) *Manuel du Conducteur des Machines Binaires*, Lyons, 1850-1851. (25) Peabody, *Thermodynamics*, 1907, 283. (26) Thurston, *Engine and Boiler Trials*, p. 130. (27) Ripper, *Steam Engine Theory and Practice*, 1905, p. 412. (28) *Experimental Engineering*, 1907. (29) *The Steam Engine Indica-*

tor, 1898. Reference should also be made to Miller's and Hall's chapters of *Practical Instructions for using the Steam Engine Indicator*, published by the Crosby Steam Gage and Valve Company, 1905. (32) Low, *op. cit.*, pp. 103-107; Carpenter, *op. cit.*, pp. 41-55, 531, 780. (33) *Op. cit.*, p. 391. (34) *Trans. A. S. M. E.*, VI, 716. (35) *Ibid.*, XXV. (36) *Ibid.*, 1892, also XXV, 827. (37) *Ibid.*, XI. (38) *Ibid.*, XXIV, 713. (39) *Op. cit.*, 144. (40) *The Steam Engine*, p. 212. (41) *Bull. de la Soc. Ind. de Mulhouse*, 1873. (42) *Exposé Succinct*, etc.; *Revue Universelle des Mines*, 1880. (43) Carpenter, *Experimental Engineering*, 1907, 657; Peabody, *Thermodynamics*, 1907, 225. (44) *Trans. A. S. M. E.*, XXVIII, 2, 225. (45) Zeuner, *Technical Thermodynamics* (Klein), II, 449. (46) *The Steam Engine*, 1905, I, 2, 3. (47) *Locomotive Tests and Exhibits at the Louisiana Purchase Exposition*, 1906. (48) *Trans. A. S. M. E.*, 1892. (49) *Ibid.*, XXVIII, 10, 1658.

SYNOPSIS OF CHAPTER XIII

Practical Modifications of the Rankine Cycle

With valves moving instantaneously at the ends of the stroke, the engine would operate in the *non-expansive cycle*. The introduction of *cut-off* makes the cycle that of *Rankine*, modified as follows:

- (1) Port friction reduces the pressure during *admission*. This causes a loss of availability of the heat. Regulation by throttling is wasteful.
- (2) The *expansion* curve differs in shape and position from that in the ideal cycle. Expansion is *not adiabatic*. The steam at the point of cut-off contains from 25 to 70 per cent of water on account of *initial condensation*. Further condensation may occur very early in the expansion stroke, followed by *reëvaporation* later on, after the pressure has become sufficiently lowered. The exponent of the expansion curve is a function of the initial dryness. The inner surfaces only of the walls fluctuate in temperature. Condensation is influenced by
 - (a) the *temperature range*: wide limits, theoretically desirable, introduce some practical losses;
 - (b) the *size of the engine*: the exposed surface is proportionately greater in small engines;
 - (c) its *speed*: high speed gives less time for heat transfers;
 - (d) the *ratio of expansion*: wide ratios increase condensation and decrease efficiency, particularly because of increased initial condensation. Initial wetness facilitates the formation of further moisture. In good design, the ratio should be fixed to obtain reasonably complete expansion without

excessive condensation, say at 4 or 5 to 1. $M = \frac{0.27}{\sqrt{N}} \sqrt{\frac{sT}{pe}}$. Values of T .

Steam jackets provide steam insulation at constant temperature; they oppose initial condensation in the cylinder and are used principally with *slow speeds* and *high ratio of expansion*. Some saving is always shown. *Superheat*, used under similar conditions, increases the mean temperature of heat absorption. Each 75° of superheat may increase the dryness at cut-off by 10 per cent. The *actual expansion curve* averages $PV = pv$. M. E. P. = $\frac{P_B(1 + \log r)}{r} - P_D$ with the Rankine

form of cycle. $H. P. = \frac{2 \times \text{diagram factor} \times mALN}{33000}$. Diagram factor = 0.5 to

$$0.9. \quad \text{With polytropic expansion, M. E. P.} = \frac{nP_B}{r(n-1)} - P_D - \frac{P_B}{r^n(n-1)}.$$

- (3) *The exhaust line* shows *back pressure* due to friction of ports, the presence of air, and reëvaporation. High altitudes increase the capacity of non-condensing engines.
- (4) *Clearance* varies from 2 to 15 per cent. "Real" and "apparent" ratios of expansion.
- (5) *Compression* brings the piston to rest quietly; though theoretically less desirable than jacketing, it may reduce initial condensation.
- (6) *Valve action* is not instantaneous, and the corners of the diagram are always somewhat rounded. Leakage is an important cause of waste.

The Steam Engine Cycle on the Entropy Diagram.

Cushion steam, present throughout the cycle, is not included in measurements of steam used.

Its volumes may be deducted, giving a diagram representing the behavior of the *cylinder feed* alone.

The indicator diagram shows actions neither cyclic nor reversible: it depicts a *varying mass of steam*.

The *Boulvin diagram* gives the *NT* history correctly along the expansion curve only.

The *Reeve diagram* eliminates the cushion steam; it correctly depicts both expansion and compression curves, as referred to the cylinder feed.

The preferred diagram plots the expansion and compression curves separately.

Diagrams may show (a) loss by condensation, (b) gains by increased pressure and decreased back pressure, (c) gains by superheating and jacketing.

Multiple Expansion

Increased initial pressure and decreased back pressure pay best with wide expansive ratios.

Such ratios are possible, with multiple expansion, without excessive condensation.

Condensation is less serious because of (a) the use made of reëvaporated steam, (b) the decrease in initial condensation, and (c) the small size of the high-pressure cylinder.

Several numbers and arrangements of cylinders are possible with expansion in two, three, or four stages.

Incidental advantages: less steam lost in clearance space; compression begins later; the large cylinder is subjected to low pressure only; more uniform speed and moderate stresses.

The *Woolf engine* had no receiver; the low-pressure cylinder received steam throughout the stroke as discharged by the high-pressure cylinder. The former, therefore, worked without expansion. The piston phases coincided or differed by 180°.

In the *receiver engine*, the pistons may have any phase relation and the low-pressure cylinder works expansively. Early cut-off in the low-pressure cylinder increases its proportion of the load, and is practically without effect on the total work of the engine.

The approximate point of low-pressure cut-off to eliminate drop may be graphically or analytically determined for tandem and cross-compound engines.

In combining diagrams, *two saturation curves* are necessary, unless the cushion steam be deducted.

The *diagram factor* has an approximate value the same as that in a simple engine having $\sqrt[n]{n}$ expansions, in which n is the number of expansions in the compound engine and c its number of expansive stages.

Cylinder ratios are 3 or 4 to 1 if non-condensing, 4 or 6 to 1 if condensing, in compounds; triples have ratios from 1:2.0:2.0 to 1:2.5:2.5. A large high-pressure cylinder gives high overload capacity.

The engine may be designed so as to *equalize work areas*, or by *assuming the cylinder ratio*. "Equivalent simple cylinder." Values of R .

Governing should be by varying the point of cut-off in *both* cylinders.

Drop in any but the last cylinder is usually considered undesirable.

Exceptionally high efficiency is shown by compounds having cylinder ratios of 7 to 1.

The high-pressure cylinder in ordinary compounds is too large for highest efficiency.

The *binary vapor engine* employs the waste heat of the exhaust to evaporate a fluid having a lower boiling point than can be attained with steam. Additional work may then be evolved down to a rejection temperature of 60 or 70° F. The best result achieved is 167 B. t. u. per Ihp.-minute.

Engine Tests

The *indicator* measures pressures and volumes in the cylinder and thus shows the "cycle."

Its diagram gives the m. e. p. and points out errors in valve adjustment or control.

Calorimeters: the *barrel* type: $x_0 = \frac{h_1(w + W) - wh - Wh_0}{WL_0}$;

surface condensing: $x_0 = \frac{wh_1 + Wh_2 - wh - Wh_0}{WL_0}$;

superheating: $x_0 = \frac{H + k(T - t) - h_0}{L_0}$; limits of capacity;

Barrus: $x_0 = \frac{H + k(T - t) - h_0 - Q}{L_0}$;

separating: direct weighing of the steam and water;

chemical: insolubility of salts in dry steam;

electrical: 1 B. t. u. per minute = 17.59 watts.

Engine trials: we may measure either the *heat absorbed* or the *heat rejected + the work done*.

By measuring *both*, we obtain a *heat balance*.

Results usually stated: lb. dry or actual steam per Ihp.-hr.; B. t. u. per Ihp.-minute; thermal efficiency; work per lb. steam; Carnot efficiency; Clausius efficiency; efficiency ratios.

By assuming the steam dry at compression and cut-off or release, and knowing the clearance, we may roughly estimate *steam consumption from the indicator diagram*.

Duty = ft.-lb. of work per 100 lb. coal (or per 1,000,000 B. t. u.) *Plant efficiency* = $\frac{\text{B. t. u. of work}}{\text{B. t. u. in coal}}$. *Mechanical efficiency* = $\frac{\text{Brake hp.}}{\text{Indicated hp.}}$.

Hirn's analysis: $E_x = \Sigma M(h_x + x_x r_x)$; $H_x = E_x + W_x$; heat transfer to and from walls may be computed from the supply of heat, the change in internal energy, and the work done. The excess of losses over gains represents radiation.

Testing of regulation (speed control).

Types of Steam Engine

Standard engines: non-condensing or condensing; right-hand or left-hand; simple or multiple expansion; single-acting or double-acting; rotative or non-rotative; duplex or single; horizontal, vertical, or inclined; locomotive, stationary (pumping, mill, power plant), or marine; belted, direct-connected, or rope-driven; air compressors; girder, tangye, or semi-tangye frames; slow, medium, or high speed; throttling, automatic, four-valve, or releasing gear. The Stumpf uniflow engine.

The *power plant:* feed pump, boiler, engine, condenser.

The *locomotive:* tractive power = $\frac{d^2 L p}{D}$; adhesion = 0.22 to 0.25 \times weight on drivers; two-cylinder and four-cylinder compounds; the balanced compound; high economy of locomotive engines.

PROBLEMS

1. Show from Art. 426 that the loss by a throttling process is equal to the product of the increase of entropy by the absolute temperature at the end of the process.
2. Ignoring radiation, how fast are the walls gaining heat because of transfers during expansion in an engine running at 100 r. p. m., in which $\frac{1}{3}$ pound of steam is condensed per revolution at a mean pressure of 100 lb., and 0.30 pound is reëvaporated at a mean pressure of 42 lb.? (*Ans.*, 3637 B. t. u. per minute).
- 3 a. Plot curves representing the results of the tests given in Art. 434.
- 3 b. Represent by a curve the results of the Barrus tests, Art. 436.
4. All other factors being the same, how much less initial condensation, at $\frac{1}{4}$ cut-off, should be found in an engine $30\frac{1}{2}'' \times 48''$ than in one $7'' \times 7''$? (Art. 437).
5. Sketch a curve showing the variation in engine efficiency with ratio of expansion.
6. Find the percentage of initial condensation at $\frac{1}{4}$ cut-off in a non-condensing engine using dry steam, running at 100 r. p. m. with a pressure at cut-off of 120 lb., the engine being $30\frac{1}{2}'' \times 48''$ (Art. 437).
7. In Fig. 193, assuming the initial pressure to have been 100 lb., the feed-water temperature 90° F., find the approximate thermal efficiencies with the various amounts of superheat at a load of 15 hp.
8. In an ideal Clausius cycle with initially dry steam between $p=140$ and $p=2$ (Art. 417), by what percentage would the efficiency be increased if the initial pressure were made 160 lb.? By what percentage would it be *decreased* if the *lower* pressure were made 6 lb.?
9. Find the mean effective pressure in the ideal cycle with hyperbolic expansion and no clearance between pressure limits of 120 and 2 lb., with a ratio of expansion of 4. (*Ans.*, 69.6 lb.)
10. Find the probable indicated horse power of a double-acting engine with the best type of valve gear, jackets, etc., operating as in Problem 9, at 100 r. p. m., the cylinder being $30\frac{1}{2}'' \times 48''$. (Ignore the piston rod.) (*Ans.*, 1107 hp.)

11. In Problem 9, what percentage of power is lost if the lower pressure is raised to $3\frac{1}{2}$ lb. ? (*Ans.*, 3.2 per cent.)

12. By what percentage would the capacity of an engine be increased at an altitude of 10,000 ft. as compared with sea level, at 120 lb. initial gauge pressure and a back pressure 1 lb. greater than that of the atmosphere, the ratio of expansion being 4 ? (Atmospheric pressure decreases $\frac{1}{2}$ lb. per 1000 ft. of height.)

3. An engine has an apparent ratio of expansion of 4, and a clearance amounting to 0.05 of the piston displacement. What is its real ratio of expansion ? (*Ans.*, 3.5.)

14. In the dry steam Clausius cycle of Problem 8, by what percentage are the capacity and efficiency affected if expansion is hyperbolic instead of adiabatic ? Discuss the results.

15. In an engine having a clearance volume of 1.0 and a back pressure of 2 lb., the pressure at the end of compression is 40 lb. If the compression curve is $PV^{1.03} = c$, what is the volume at the beginning of compression ? (*Ans.*, 18.28.)

16. An engine works between 120 and 2 lb. pressure, the piston displacement being 20 cu. ft., clearance 5 per cent, and apparent ratio of expansion 4. The expansion curve is $PV^{1.02} = c$, the compression curve $PV^{1.03} = c$, and the final compression pressure is 40 lb. Plot the PV diagram with actual volumes of the cushion steam eliminated.

17. In Problem 16, 1.825 lb. of steam are present per cycle. Plot the entropy diagram from the indicator card by Boulvin's method.

18. In Problems 16 and 17, compute and plot the entropy diagram by Reeve's method, assuming the steam dry at the beginning of compression. (See Art. 457.) Discuss any differences between this diagram and that obtained in Problem 17.

19. In a non-expansive cycle, find the theoretical changes in capacity and economy by raising the initial pressure from 100 to 120 lb., the back pressure being 2 lb. (*Ans.*, 1.2 per cent gain in capacity ; 8.5 per cent increase in efficiency.)

20. A non-expansive engine with limiting volumes of 1 and 6 cu. ft. and an initial pressure of 120 lb., without compression, has its back pressure decreased from 4 to 2 lb. Find the changes in capacity and efficiency. The same steam is now allowed to expand hyperbolically to a volume of 21 cu. ft. Find the effects following the reduction of back pressure in this case. The steam is in each case dry at the point of cut-off.

(*Ans.*, (a) 1.7 per cent increase in capacity and efficiency ; (b) 3.2 per cent increase in capacity and efficiency.)

21. Find the cylinder dimensions of an automatic engine to develop 30 horse power at 300 r. p. m., non-condensing, at $\frac{1}{4}$ cut-off, the initial pressure being 100 lb. and the piston speed 300 ft. per minute. The engine is double-acting.

22. Sketch a possible cylinder arrangement for a quadruple-expansion engine with seven cylinders, three of which are vertical and four horizontal, showing the receivers and pipe connections.

23. Using the ideal combined diagram for a compound engine with a constant receiver pressure, clearance being ignored, what must that receiver pressure be to divide the diagram area equally, the pressure limits being 120 and 2 and the ratio of expansion 16 ?

24. Consider a simple engine $30\frac{1}{2}'' \times 48''$ and a compound engine $15\frac{1}{4}''$ and $30\frac{1}{2}'' \times 48''$, all cylinders having 5 per cent of clearance and no compression. What are the amounts of steam theoretically wasted in filling clearance spaces in the simple

engine and in the high-pressure cylinder of the compound, the pressures being as in Problem 23 ?

25. Take the same engines. The simple engine has a real ratio of expansion of 4; the compound is as in Problems 23 and 24. Compression is to be carried to 40 lb. in the simple engine and to 60 lb. in the compound in order to prevent waste of steam. By what percentages are the work areas reduced in the two engines under consideration ?

26. A cross-compound double-acting engine operates between pressure limits of 120 and 2 lb. at 100 r. p. m. and 800 ft. piston speed, developing 1000 hp. Find the sizes of the cylinders under the following assumptions, there being no drop: (a) diagram factor 0.85, 20 expansions, receiver pressure 24 lb.; (b) diagram factor 0.85, 20 expansions, work equally divided; (c) diagram factor 0.85, 20 expansions, cylinder ratio 5:1; (d) diagram factor 0.83, 32 expansions, work equally divided. Find the power developed by each cylinder in (a) and (c). Find the size of the cylinder of the equivalent simple engine having a diagram factor of 0.80 with 20 expansions. Draw up a tabular statement of the five designs and discuss their comparative merits.

27. In Problem 26, Case (a), the receiver volume being equal to that of the low-pressure cylinder, find graphically and analytically the point of cut-off on the low-pressure cylinder.

28. Trace the combined diagram for one end of the cylinder from the first set of cards in Fig. 230, assuming the clearance in each cylinder to have been 15 per cent of the piston displacement, the cylinder ratio 3 to 1, and the pressure scales of both cards to be the same.

29. Show on the entropy diagram the effect of reheating.

30. In Art. 483, what was the Carnot efficiency of the Josse engine? Assuming it to have been used in combination with a gas engine, the maximum temperature in the latter being 3000° F., by what approximate amount might the Carnot efficiency of the former have been increased? (The temperature of saturated sulphur dioxide at 35 lb. pressure is 52° F.)

31. An indicator diagram has an area of 82,192.5 foot-pounds. What is the mean effective pressure if the engine is $30\frac{1}{2}'' \times 48''$? What is the horse power of this engine if it runs double-acting at 100 r. p. m.? (Ans., 28.1 lb.; 498 hp.)

32. Given points 1, 2 on a hyperbolic curve, such that $V_2 - V_1 = 15$, $P_1 = 120$, $P_2 = 34.3$, find the OP -axis.

33. An engine develops 500 hp. at full load, and 62 hp. when merely rotating its wheel without external load. What is its mechanical efficiency? (Ans., 0.876.)

34. Steam at 100 lb. pressure is mixed with water at 100°. The weight of water increases from 10 to 11 lb., and its temperature rises to 197½°. What was the percentage of dryness of the steam? (Ans., 95 per cent.)

35. The same steam is condensed in and discharged from a coil, its temperature becoming 210°, and 10 lb. of surrounding water rise in temperature from 100° to 204¼°. Find the quality of the steam. What would have been an easier way of determining the quality?

36. What is the maximum percentage of wetness that can be measured in a throttling calorimeter in steam at 100 lb. pressure, if the discharge pressure is 30 lb.?

(Ans., 2.5 per cent.)

37. Steam at 100 lb. pressure has added to it from an external source 30 B. t. u.

per pound. It is throttled to 30 lb. pressure, its temperature becoming 270.3° . What was its dryness? (*Ans.*, 0.955.)

38. Under the pressure and temperature conditions of Problem 37, the added heat is from an electric current of 5 amperes provided for one minute, the voltage falling from 220 to 110. What was the amount of heat added and the percentage of dryness of the steam? (See Art. 494.) (*Ans.*, 95.4 per cent.)

39. An engine consumes 10,000 lb. of dry steam per hour, the moisture having been completely eliminated by a receiver separator which at the end of one hour is found to contain 285 lb. of water. What was the dryness of the steam entering the separator? (*Ans.*, 97.2 per cent.)

A double-acting engine at 100 r. p. m. and a piston speed of 800 feet per minute gives an indicator diagram in which the pressure limits are 120 and 2 lb., the volume limits 1 and 21 cu. ft. The apparent ratio of expansion is 4. The expansion curve follows the law $PV^{1.02}=c$. Compression is to 40 lb., according to the law $PV^{1.03}=c$. Disregard rounded corners. The boiler pressure is 130 lb., the steam leaving the boiler is dry, the steam at the throttle being 95 per cent dry and at 120 lb. pressure. The boiler evaporates 26,500 lb. of steam per hour; 2000 lb. of steam are supplied to the jackets at 120 lb. pressure. The engine runs jet-condensing, the inlet water weighing 530,000 lb. per hour at 43.85° F., the outlet weighing 554,000 lb. at 90° F. The coal burned is 2700 lb. per hour, its average heat value being 14,000 B. t. u. Compute as follows:

40. The mean effective pressure and indicated horse power. (NOTE. The work quantities under the curves must be computed with much accuracy.)

(*Ans.*, 68.57 lb.; 1196.8 hp.)

41. The cylinder dimensions of the engine. (*Ans.*, 30.24 by 48 in.)

42. The heat supplied at the throttle per pound of cylinder and jacket steam, and the B. t. u. consumed per Ihp. per minute; the engine being charged with heat above the temperatures of the respective discharges (Art. 502). (*Ans.*, (a) 1145.6; (b) 394.)

43. The dry steam consumption per Ihp.-hr., thermal efficiency, and work per pound of dry steam. (*Ans.*, (a) 20.6; (b) 0.108; (c) 123 B. t. u.)

44. The Carnot efficiency, the Clausius efficiency, and the efficiency ratio, taking the limiting conditions as at the throttle and the condenser outlet.

(*Ans.*, (a) 0.31, (b) 0.27, (c) 0.39 (as compared with the Clausius cycle).)

45. The cylinder feed steam consumption computed as in Art. 500; the consumption thus computed but assuming $x=0.80$ at release, $x=1.00$ at compression. Compare with Problem 43.

46. The percentage of steam lost by leakage (all leakage occurring between the boiler and the engine); the transmissive efficiency; the unaccounted-for losses.

(*Ans.*, (a) 1.89; (b) 94.3 per cent (loss=1,774,860 B. t. u.); (c) 250,375 B. t. u.)

47. The duty, the efficiency of the plant, and the boiler efficiency.

48. The heat transfers and the loss of heat by radiation, as in Art. 504, assuming $x=1.00$ at compression. Compare the latter with the unaccounted-for heat obtained in Problem 46.

49. The value of the mechanical equivalent of heat which might be computed from the experiment. (*Ans.*, 720.)

50. Explain the meaning of the figure 2068.84 in Art. 503.
51. Revise Fig. 233, showing the arrangement of machinery and piping if a *surface* condenser is used.
52. A locomotive weighing 200,000 lb. carries, normally, 60 per cent of its weight on its drivers. The cylinders are 19"×26", the wheels 66" in diameter. What is the maximum boiler pressure that can be profitably utilized? If the engine has a traction increaser that may put 12,000 lb. additional weight on the drivers, what maximum boiler pressure may then be utilized?
53. Represent Fig. 217 on the PV diagram.
54. Find the steam consumption in lb. per Ihp.-hr. of an ideal engine working in the Clausius cycle between absolute pressures of 150 lb. and 2 lb., the steam containing 2 per cent of moisture at the throttle. What is the thermal efficiency?
55. What horse power will be given by the engine in Problem 10 if the ratio of expansion is made (a) 5, (b) 3?
56. If an engine use dry steam at 150 lb. absolute pressure, what change in efficiency occurs when the back pressure is reduced from 2 to $\frac{1}{2}$ lb. absolute, if the ratio of expansion is 30? If the ratio of expansion is 100?

CHAPTER XIV

THE STEAM TURBINE

512. The Turbine Principle. Figure 235 shows the method of using steam in a typical impulse turbine. The expanding nozzles discharge a jet of steam at high velocity and low pressure against the blades or buckets, the impulse of the steam causing rotation. We have here, not expansion of high pressure steam against a piston, as in the ordinary engine, but utilization of the kinetic energy of a rapidly flowing stream to produce movement. One of the assumptions of Art. 11 can now no longer hold. All of the expansion occurs in the nozzle; the expansion produces velocity, the *velocity* does work. The lower the pressure at which the steam leaves the nozzle, the greater is the velocity attained. It will presently be shown that to fully utilize the energy of velocity, the buckets must themselves move at a speed proportionate to that of the steam. This involves extremely high rotative speeds.

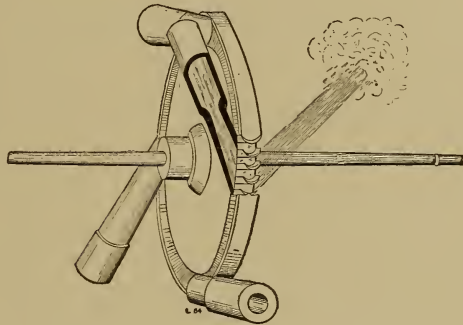

FIG. 235. Arts. 512, 524, 536. — De Laval Turbine Wheel and Nozzles.

The steps in the design of an impulse turbine are (*a*) determination of the velocity produced by expansion, (*b*) computation of the nozzle dimensions necessary to give the desired expansion, and (*c*) the proportioning of the buckets.

513. Expansive Path. There is a gradual fall of pressure while the steam passes through the nozzle. With a given initial pressure, the pressure and temperature at any stated point along the nozzle should never change. There is, therefore, no tendency toward a transfer of heat between steam and walls. Further, the extreme rapidity of the movement gives no time for such transfer; so that the process in the nozzle is truly adiabatic, although friction renders it non-isentropic. The first problem of turbine design is then to determine the changes of velocity, volume, temperature or dryness, and pressure, during such adiabatic expansion, for a vapor initially wet, dry, or superheated; the method may be accu-

rate, approximate (exponential), or graphical. The results obtained are to include the effect of nozzle friction.

514. The Turbine Cycle. Taking expansion in the turbine as adiabatic and as carried down to the condenser pressure, the cycle is that of Clausius, and is theoretically more efficient than that of any ordinary steam engine working through the same range. *The turbine is free from losses due to interchange of heat with the walls.* The practical losses are four:

(a) Friction in the nozzles, causing a fall of temperature without the performance of work;

(b) Incomplete utilization of the kinetic energy by reason of the assumed blade angles and residual velocity of the emerging jet (Art. 528);

(c) Friction along the buckets, increasing as some power of the stream speed;

(d) Mechanical friction of journals and gearing, and friction between steam and rotor as a whole.

515. Heat Loss and Velocity. In Fig. 236, let a fluid flow adiabatically from the vessel *a* through the frictionless orifice *b*. Let the internal energy of the substance be *e* in *a* and *E* in *b*; the velocities *v* and *V*; the pressures *p* and *P*; and the specific volumes *w* and *W*. If the velocities could be ignored, as in previous computations, the volume of each pound of fluid in *a* would decrease by *w* in passing out at the constant pressure *p*; and the volume of each pound of fluid in *b* would increase by *W* at the constant pressure *P*. The net external work done would be *PW* - *pw*, the net loss of internal energy *e* - *E*, and these two quantities would be equal. With appreciable velocity effects, we must also consider the kinetic energies in *a* and *b*; these are

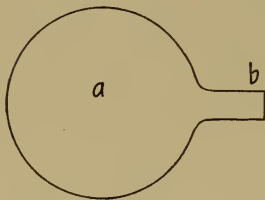

FIG. 236. Art. 515.—Flow through Orifice.

$$\frac{v^2}{2g} \text{ and } \frac{V^2}{2g};$$

and we now have

$$H = T + I + W + V,$$

$$(T + I) + W + V = 0,$$

$$(E - e) + (PW - pw) + \left(\frac{V^2}{2g} - \frac{v^2}{2g}\right) = 0,$$

$$E + PW + \frac{V^2}{2g} = e + pw + \frac{v^2}{2g},$$

or

$$\frac{V^2}{2g} - \frac{v^2}{2g} = pw - PW + e - E.$$

Let X, U, H, R , and x, u, h, r , be the dryness, increase of volume during vaporization, heat of liquid, and internal latent heat, at PW and pw respectively; let s be the specific volume of water; then for expansion of a vapor from pw to PW within the saturated region,

$$\begin{aligned} \frac{V^2}{2g} - \frac{v^2}{2g} &= p(xu + s) - P(XU + s) + h + xr - H - XR \\ &= q - Q + s(p - P), \end{aligned}$$

in which q, Q represent total heats of wet vapor above 32 degrees. If expansion proceeds from the superheated to the saturated region,

$$\begin{aligned} \frac{V^2}{2g} - \frac{v^2}{2g} &= p\{(u + s) + (w - n)\} - P(XU + s) + h + r \\ &\quad + \frac{p(w - n)}{y - 1} - H - XR, \end{aligned}$$

in which $n = u + s$ is the volume of saturated steam at the pressure p , w is the volume of superheated steam, and

$$\frac{p(w - n)}{y - 1}$$

is the internal energy measured above saturation.* This also reduces to $q - Q + s(p - P)$, where q is the total heat in the superheated steam, and the same form of expression will be found to apply to expansion wholly in the superheated region. The gain in kinetic energy of a jet due to adiabatic expansion to a lower pressure is thus equivalent to the decrease in the total heat of the steam plus the work which would be required to force the liquid back against the same pressure head. In

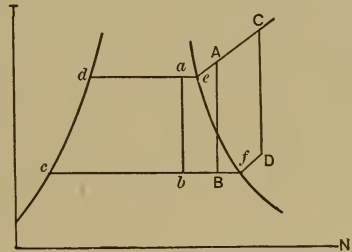

FIG. 237. Art. 515.—Adiabatic Heat Drop.

Fig. 237, let ab, AB, CD , represent the three paths. Then the losses of heat are represented by the areas $dabc, deABe, deCDfc$.

* For any gas treated as perfect, the gain of internal energy from t to T is

$$l(T - t) = \frac{k}{y} (T - t) = \frac{R}{y - 1} (T - t) = \frac{PV - pv}{y - 1},$$

or in this case, since internal energy is gained at constant pressure,

$$= \frac{p(w - n)}{y - 1}.$$

The term $s(p-P)$ being ordinarily negligible, these areas also represent the kinetic energy acquired, which may be written

$$\frac{V^2}{2g} - \frac{v^2}{2g} = q - Q.$$

In the turbine nozzle, the initial velocity may also, without serious error, be regarded as negligible; whence

$$\frac{V^2}{2g} = q - Q \text{ or } V = \sqrt{50103.2(q - Q)} = 223.84\sqrt{q - Q} \text{ feet per second.}$$

516. Computation of Heat Drop. The value of $q - Q$ may be determined for an adiabatic path between stated limits from the entropy diagram, Fig. 175, or from the Mollier diagram, Fig. 177. Thus, from the last named, steam at 100 lb. absolute pressure and at 500° F. contains 1273 B. t. u. per pound; steam 85 per cent dry at 3 lb. absolute pressure contains 973 B. t. u. Steam at 150 lb. absolute pressure and 600° F. contains 1317 B. t. u. If it expand adiabatically to 2.5 lb. absolute pressure, its condition becomes 88 per cent dry, its heat contents 1000 B. t. u., and the velocity produced is

$$223.84\sqrt{317} = 4000 \text{ ft. per second.}$$

517. Vacuum and Superheat. The entropy diagram indicates the notable gain due to high vacua and superheat. Comparing dry steam expanded from 150 lb. to 4 lb. absolute pressure with the same steam superheated to 600° and expanded to 2.5 lbs. absolute pressure, we find $q - Q$ in the former case to be 63 B. t. u., and in the latter, 317 B. t. u. The corresponding values of V are 1770 and 4000 ft. per second. The turbine is peculiarly adapted to realize the advantages of wide ratios of expansion. These do not lead to an abnormally large cylinder, as in ordinary engines; the "toe" of the Clausius diagram, Fig. 184, is gained by allowing the steam to leave the nozzle at the condenser pressure. Superheat, also, is not utilized merely in overcoming cylinder condensation; it increases the available "fall" of heat, practically without diminution.

518. Effect of Friction. If the steam emerging from the nozzle were brought back to rest in a closed chamber, the kinetic energy would be reconverted into heat, as in a wiredrawing process, and the expanded steam would become superheated. Watkinson has, in fact, suggested this (1) as a method of superheating steam, the water being mechanically removed at the end of expansion, before re-conversion to heat began. In the nozzle, in practice, the friction of the steam against the walls does partially convert the velocity energy back to heat, and the heat drop and velocity are both less than in the ideal case.

The efficiencies of nozzles vary according to the design from 0.90 to 0.97. The corresponding variation in ratio of actual to ideal velocity is 0.95 to 0.99.

In Fig. 238, for adiabatic expansion from p, v, q , to P, V, Q , the velocity imparted is

$$223.84 \sqrt{q - Q}.$$

During expansion from p, v, q , to P_1, V_1, Q_1 , the velocity imparted is

$$223.84 \sqrt{q - Q_1}.$$

Since V_1 exceeds V , the steam is more nearly dry at V_1 ; i.e. Q_1 exceeds Q . The loss of energy due to the path $pvq - P_1V_1Q_1$ as compared with $pvq - PVQ$, is

$$\frac{X^2}{2g} = Q_1 - Q,$$

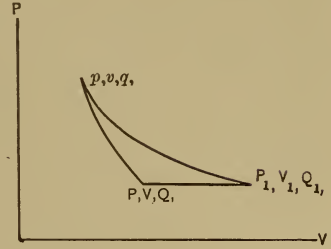

FIG. 238. Art. 518.—Adiabatic Expansion with and without Friction.

in which X^2 is the difference of the squares of the velocities at Q and Q_1 . This gives $X^2 = 50103.2 (Q_1 - Q)$. In Fig. 239, let NA be the adiabatic path, NX the modified path due to friction.

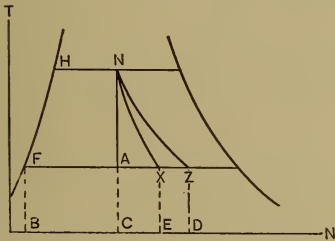

FIG. 239. Art. 518.—Expansive Path as Modified by Friction.

NZ represents a curve of constant total heat; along this, no work would be done, but the heat would steadily lose its availability. As NX recedes from NA toward NZ , the work done during expansion decreases. Along NA , all of the heat lost (area $FHNA$) is transformed into work; along NZ , no heat is lost and no work is done, the areas $BFHNC$ and $BFZD$ being equal. Along NX , the heat transformed into work is $BFHNC - BFXE = FHNA - CAXE$, less than that during adiabatic expansion by the amount of work converted back to heat. Considering expansion from N to Z ,

$$V = 223.84 \sqrt{q - Q_1} = 0,$$

since $q = Q_1$. Nozzle friction decreases the heat drop, the final velocity attained, and the external work done.

519. Allowance for Friction Loss. For the present, we will assume nozzle friction to reduce the heat drop by 10 per cent. In Fig. 240, which is an enlarged view of a portion of Fig. 177, let AB represent adiabatic (isentropic) expansion from the condition A to the state B . Lay off

$$BC = \frac{AB}{10},$$

and draw the line of constant heat CD . Then D is the equivalent final

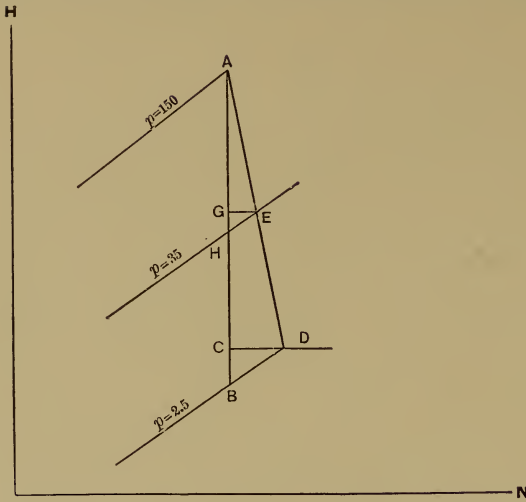

state at the same pressure as that existing at B , and AC represents the heat drop corrected for friction. Similarly by laying off

$$HG = \frac{AH}{10}$$

and drawing GE to intersect the 35-lb. pressure line, we find the point E on the path AD of the steam through the nozzle. We may use the new heat drop thus obtained in determining V ; or generally, if m is the friction loss,

FIG. 240. Arts. 519, 524, 525, 532, 534. — The Steam Path of the Turbine.

$$\frac{V^2}{2g} = (1 - m)(q - Q)$$

and

$$V = 223.84 \sqrt{1 - m} \sqrt{q - Q}.$$

If $m = 0.10$, $V = 212.42 \sqrt{q - Q}$.

520. Analytical Relations. The influence of friction in determining the final condition of the steam may be examined analytically. For example, let the initial condition be wet or dry; then friction will not ordinarily cause superheating, so that the steam will remain saturated throughout expansion. Without friction, the final dryness x_0 would be given by the equation (Art. 392),

$$\log_e \frac{t}{T} + \frac{x_l}{t} = \frac{x_0 l_0}{T}.$$

Friction causes a return to the steam of the quantity of heat $m(q - Q)$. This increases the final dryness by $\frac{m(q - Q)}{l_0}$, making it

$$X_0 = \frac{T \left\{ \log_e \frac{t}{T} + \frac{x_l}{t} \right\} + m(q - Q)}{l_0}.$$

If the initial condition is superheated to t_s , and the final condition saturated, adiabatic expansion would give

$$\log_e \frac{t}{T} + \frac{l}{t} + k \log_e \frac{t_s}{t} = \frac{x_0 l_0}{T},$$

and friction would make the final condition

$$X_0 = \frac{T \left\{ \log_e \frac{t}{T} + \frac{l}{t} + k \log_e \frac{t_s}{t} \right\} + m(q - Q)}{l_0}.$$

If the steam is superheated throughout expansion, we have for the final temperature T_s , without friction,

$$\log_e \frac{t}{T} + \frac{l}{t} + k \log_e \frac{t_s}{t} = \frac{l_0}{T} + k_0 \log_e \frac{T_s}{T},$$

in which the value of k_0 must be obtained by successive approximations.

521. Rate of Flow. For a flow of G pounds per second at the velocity V , when the specific volume is W , the necessary cross-sectional area of nozzle is $F = \frac{GW}{V}$.

The values of W and V may be read or inferred from the heat chart or the formulas just given. In Fig. 241 (2), let ab represent frictionless adiabatic expansion on the TN plane, $a'b'$ the same process on the PV plane. By finding q_a and values of Q at various points along ab , we may obtain a series of successive values of V . The corresponding values of W being read from a chart or computed, we plot the curve MN , representing the relation of specific volume and velocity throughout the expansion. Draw yy' parallel to OW , making $Oy = G$, to some convenient scale. Draw any line OD from O to MN , intersecting yy' at k . From similar triangles, $yk : yO :: On : nD$, or $yk = \frac{GW}{V} = F$.

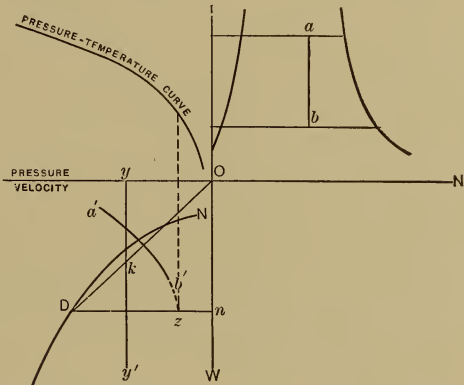

FIG. 241. Art. 521.—Graphical Determination of Nozzle Area.

From similar triangles, $yk : yO :: On : nD$, or $yk = \frac{GW}{V} = F$.

To find the pressure at any specified point on the nozzle, lay off $yk = F$, draw OkD , Dn , and project z to the PT plane. The minimum value of F is reached when OD is tangent to MN . It becomes infinite when $V = 0$. The conclusion that the cross-sectional area of the nozzle reaches a minimum at a certain stage in the expansion will be presently verified.

522. Maximum Flow (2a). For a perfect gas,

$$e = \frac{pw}{y-1}, \quad E = \frac{PW}{y-1}.$$

If the initial velocity be negligible, we have, as the equation of flow (Art. 515),

$$\frac{V^2}{2g} = pw - PW + \frac{pw}{y-1} - \frac{PW}{y-1} = \frac{y}{y-1}(pw - PW);$$

and since

$$pw^y = PW^y, \quad PW = pw \left(\frac{w}{W} \right)^{y-1} = pw \left(\frac{P}{p} \right)^{\frac{y-1}{y}}$$

Then

$$\frac{V^2}{2g} = \frac{y}{y-1} \left[pw \left\{ 1 - \left(\frac{P}{p} \right)^{\frac{y-1}{y}} \right\} \right] = Rt \frac{y}{y-1} \left\{ 1 - \left(\frac{P}{p} \right)^{\frac{y-1}{y}} \right\}.$$

From Art. 521,

$$G = \frac{FV}{W} = FV \div w \left(\frac{p}{P} \right)^{\frac{1}{y}} = FV \div \frac{Rt \left(\frac{p}{P} \right)^{\frac{1}{y}}}{p}.$$

Taking the value of V at

$$\sqrt{2g \frac{y}{y-1} Rt \left\{ 1 - \left(\frac{P}{p} \right)^{\frac{y-1}{y}} \right\}},$$

we obtain

$$G = \frac{pF \sqrt{2g \frac{y}{y-1} Rt \left\{ 1 - \left(\frac{P}{p} \right)^{\frac{y-1}{y}} \right\}}}{Rt \left(\frac{p}{P} \right)^{\frac{1}{y}}} = \frac{Fp \sqrt{2g}}{\sqrt{i} R} \left[\frac{y}{y-1} \left\{ \left(\frac{P}{p} \right)^{\frac{2}{y}} - \left(\frac{P}{p} \right)^{\frac{y+1}{y}} \right\} \right]^{\frac{1}{2}}.$$

This reaches a maximum, for air, when $P \div p = 0.5274$ (3). The velocity is then equal to that of sound. For dry steam, on the assumption that $y = 1.135$, and that the above relations apply, the ratio for maximum flow is 0.577.

Using the value just given for the ratio $P \div p$, with $y = 1.402$, the equation for G simplifies to

$$G = 0.491 Fp \sqrt{\frac{2g}{Rt}},$$

the equation of flow of a permanent gas, which has been closely confirmed by experiment. With steam, the ratio of the specific heats is more variable, and the ratio of pressures has not been as well confirmed experimentally. Close approximations have been made. Clarke (4), for example, shows maximum flow with saturated steam to occur at an average ratio of 0.56. The pressure of maximum flow determines the minimum or *throat* diameter of the nozzle, which is independent of the discharge pressure. The emerging velocity may be greater than that in the throat if the steam is allowed to further expand after passing the throat. The nozzle should in all cases continue beyond the throat, either straight or expanding, if the kinetic energy is all to be utilized in the direction of flow.

In all cases, the steam velocity theoretically attained at the throat of the nozzle will be 1450 ft. per second.

523. Experiments. Many experiments have been made on the flow of fluids through nozzles and orifices. Those of Jones and Rathbone (5), Rosenhain (6), Gutermuth (7), Napier (8), Rateau (9), Hall (10), Wilson (11), Kunhardt (12), Buchner (13), Kneass (14), Lewicki (15), Durley (16), and chiefly, perhaps, those of Stodola (17), should be studied. There is room for further advance in our knowledge of the friction losses in nozzles of various proportions. There are several methods of experimentation: the steam, after passing the orifice, may be condensed and weighed; the pressure at various points in the nozzle may be measured by side orifices or by a searching tube; or the reaction or the impulse of the steam at its escape may be measured. The velocity cannot be measured directly.

A greater rate of flow is obtainable through an orifice in a thin plate (Fig. 242) than through an expanding nozzle (Fig. 243). For pressures under 80 lb., with discharge into the atmosphere, the plain orifice is more *efficient* in producing velocity. For wider pressure ranges, a divergent nozzle is necessary to avoid deferred expansion occurring after emergence. Expansion should not, however, be carried to a pressure lower than that of discharge. The rate of flow, but not the emerging velocity, depends upon the shape of the inlet; a slightly rounded edge (Fig. 243) gives the greatest rate; a greater amount of rounding may be less desirable. The experimentally observed critical pressure ratio $\left(\frac{P}{p}\right)$ (Art. 522) ranges with various fluids



FIG. 242. Art. 523.—Diverging Orifice.

from 0.50 to 0.85. Maximum flow occurs at the lower ratios with rather sharp corners at the entrance, and at the higher ratios when a long divergence occurs beyond the throat, as in Fig. 243. The “most efficient” nozzle will have different proportions for different pressure ranges. The pressure is, in general, greater at all points along the nozzle than theory would indicate, on account of friction; the excess is at first slight, but increases more and more rapidly during the passage. Most experiments have necessarily been made on very small orifices, discharging to the atmosphere. The friction losses in larger orifices are probably less. The experimental method should include at least two of the measurements above mentioned, these checking each other. The theory of the action in the nozzle has been presented by Heck (18). Zeuner (19) has discussed the flow of gases to and from the atmosphere (20), both under adiabatic and actual conditions, and the efflux of gases in general through orifices and long pipes.

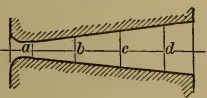

FIG. 243. Arts. 523, 525. — Expanding Nozzle.

The Curtis and Rateau turbines use a series of wheels, with expanding nozzles between the various series (Figs. 245, 246). The steam is only partially expanded in each nozzle, until it reaches the last one. Such turbines are of the **multi-stage impulse type**. During passage through the blades, the velocity decreases, while the pressure remains unchanged. In the

524. Types of Turbine. The single stage impulse turbine of Fig. 235 is that of De Laval. Its action is illustrated in Fig. 244. The pressure falls in the nozzle, and remains constant in the buckets. The Curtis and

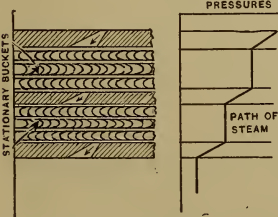

FIG. 245. Art. 524.—Curtis Turbine.

Rateau turbines use a series of wheels, with expanding nozzles between the various series (Figs. 245, 246). The steam is only partially expanded in each nozzle, until it reaches the last one. Such turbines are of the **multi-stage impulse type**. During passage through the blades, the velocity decreases, while the pressure remains unchanged. In the

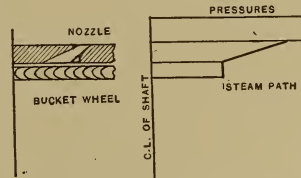

FIG. 244. Art. 524.—De Laval Turbine.

During passage through the blades, the velocity decreases, while the pressure remains unchanged. In the

pressure turbine of Parsons, there are no expanding nozzles; the steam passes successively through the stationary guide vanes G, g , and movable wheel buckets, W, w , Fig. 247.

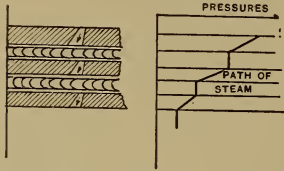

FIG. 246. Art. 524. — Rateau Turbine.

A gradual fall of pressure occurs, the buckets being at all times full of steam. In impulse turbines, the buckets need not be full of steam, and the pressure drop occurs in the nozzle only.

A lower rotative speed results from the use of several pressure stages with expanding nozzles. Let the total heat drop of 317 B. t. u., in Art. 516, be divided into three stages by three sets of nozzles.

The exit velocity from each nozzle, corrected for friction, is then $212.42\sqrt{q - Q} = 2180$ ft. per second, instead of 3790 ft. per second; laying off in Fig. 240 the three equal heat

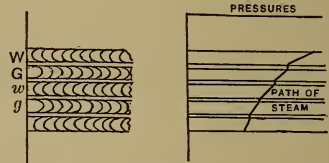

FIG. 247. Arts. 524, 533. — Parsons Turbine.

drops, we find that the nozzles expand between 150 and 50, 50 and 13, and 13 and 2.5 lb. respectively. The rotative speeds of the wheels (proportional to the emerging velocities), Art. 528, are thus reduced.

525. Nozzle Proportions; Volumes. The specific volume W of the steam at any point along the path AD , Fig. 240, having been obtained from inspection of the entropy chart, or from the equation of condition, and the velocity V at the same point having been computed from the

heat drop, the cross-sectional area of the nozzle, in square feet, is $F = \frac{WG}{V}$

(Art. 521). Finding values of F for various points along the expansive path, we may plot the nozzle as in Fig. 243, making the horizontal intervals, ab, bc, cd , etc., such that the angle between the diverging sides is about 10° , following standard practice.* It has been shown that F reaches a minimum value when the pressure is about 0.57 of the initial pressure, and then increases as the pressure falls further. If the lowest pressure exceeds 0.57 of the initial pressure, the nozzle converges toward the outlet. Otherwise, the nozzle converges and afterwards expands, as in Fig. 243. Let, in such case, o be the minimum diameter, O the outlet diameter, L the length between these diameters; then for an angle of

10° between the sides, $\frac{O}{2} - \frac{o}{2} = L \tan 5^\circ$, or $L = 5.715(O - o)$.

* A variable taper may be used to give constant acceleration of the steam

526. Work Done. The work done in the ideal cycle per pound of steam is $778(q - Q)$ foot-pounds. Since 1 horse power = 1,980,000 foot-pounds per hour, the steam consumption per hp.-hr. is theoretically $1,980,000 \div 778(q - Q) = 2545 \div (q - Q)$. If E is the efficiency ratio of the turbine, from steam to buckets, and e the efficiency from steam to shaft, then the actual steam consumption per indicated horse power is $2545 \div E(q - Q)$, and per brake horse power is $2545 \div e(q - Q)$ pounds. The modifying influences of nozzle and bucket friction in determining E are still to be considered.

527. Relative Velocities. In Fig. 248, let a jet of steam strike the bucket A at the velocity v , the bucket itself moving at the speed u . The velocity of the steam relative to the bucket is then represented in magnitude and direction by V . The angles a and e made with the plane of rotation of the bucket wheel are called the **absolute entering** and **relative entering** angles respectively. Analytically, $\sin e = v \sin a \div V$. The stream traverses the surface of the bucket, leaving it with the relative velocity x' , which for convenience is drawn as x from the point O . Without bucket friction, $x = V$. The angle f is the **relative angle of exit**. Laying off u , from z , we find Y as the **absolute exit velocity**, with g as the **absolute angle of exit**. Then, if $x = V$, $\sin g = V \sin f \div Y$.

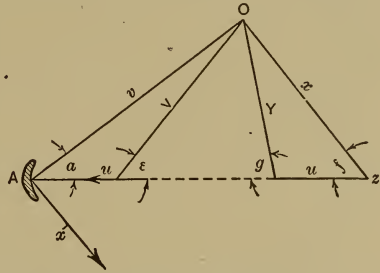

FIG. 248. Art. 527.—Velocity Diagram.

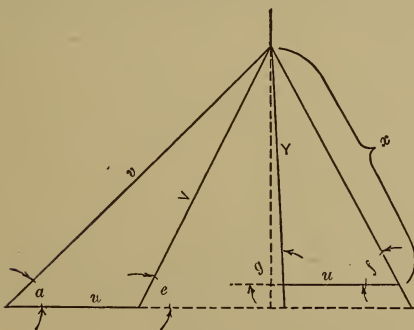

FIG. 249. Arts. 527, 532, 534.—Velocity Corrected for Friction.

(Art. 519), and making x less than V by from 5 to 20 per cent, as in ordinary practice. As before, $\sin e = v \sin a \div V$; but for a bucket friction of 10 per cent, $\sin g = 0.9 V \sin f \div Y$.

528. Bucket Angles and Work Done. In Fig. 250, the absolute velocities v and Y may be resolved into components ab and db in the direction of rotation, and ac and de at right angles to this direction. The former components are those which move the wheel; the latter produce an end thrust on the shaft. Now $ab + bd$ (bd being negative) is the **change in velocity** of the fluid in the direction of rotation; it is the **acceleration**; the *force exerted per pound* is then

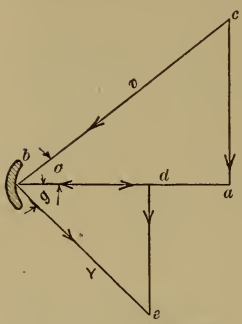

FIG. 250. Arts. 528, 529.—
Rotative and Thrust
Components.

$$\begin{aligned} (ab + bd) \div g &= (ab \mp bd) \div 32.2 \\ &= (v \cos a + Y \cos g) \div 32.2. \end{aligned}$$

This force is exerted through the distance u feet per second; the *work done per pound of steam* is then $u(v \cos a + Y \cos g) \div 32.2$ foot-pounds. This, from Art. 526, equals $778 E (q - Q)$ whence

$$E = u(v \cos a + Y \cos g) \div 25051.6(q - Q).$$

The efficiency is thus directly related to the bucket angles.

To avoid splashing, the entrance angle of the bucket is usually made equal to the relative entering angle of the jet, as in Fig. 251. (These formulas hold only when the sides of the buckets are enclosed to prevent the lateral spreading of the stream.) In actual turbines, bd (Fig. 250) is often not negative, on account of the extreme reversal of direction that would be necessary. With *positive* values of bd , the maximum work is obtained as its value approaches zero, and ultimately it is $uv \cos a \div 32.2$.

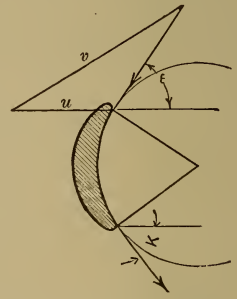

FIG. 251. Art. 528.—
Velocities and Bucket
Angles.

Since the kinetic energy of the jet is $\frac{v^2}{2g}$, the efficiency E from steam to buckets then becomes

$2 \frac{u}{v} \cos a$. In designing, we may either select an exit bucket angle which shall make bd equal to zero (the relative exit velocity being tangential to the surface of the bucket), or we may choose such an angle that the end thrust components de and ca , Fig. 250, shall bal-

ance. In marine service, some end thrust is advantageous; in stationary work, an effort is made to eliminate it. This would be accomplished by making the entrance and exit bucket angles equal, for a zero retardation by friction. With friction considered, the angle of exit K , in Fig. 251, must be *greater* than the entering angle e . In any case, where end thrust is to be eliminated, the rotative component of the absolute exit velocity must be so adjusted as to have a detrimental effect on the economy.

529. Effect of Stream Direction on Efficiency. Let the stream strike the bucket in the direction of rotation, so that the angle $\alpha = 0$, Fig. 250, the relative exit velocity being perpendicular to the plane of the wheel. The work done is $u \frac{v-u}{g}$, while the kinetic energy is $\frac{v^2}{2g}$. The efficiency, $2u \frac{v-u}{v^2}$, becomes a maximum at 0.50 when $u = \frac{v}{2}$. With a *cup-shaped vane*, as

in the Pelton wheel, Fig. 252, complete reversal of the jet occurs; the absolute exit velocity, ignoring friction, is $v - 2u$. The change in velocity is $v + v - 2u = 2(v - u)$, and the work

is $2u(v - u) \div g$, whence the efficiency, $\frac{4u(v - u)}{v^2}$, becomes a maximum at 100 per cent when $u = \frac{v}{2}$. Complete reversal in turbine buckets is impracticable.

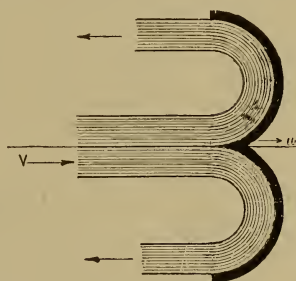

FIG. 252. Arts. 529, 536. — Pelton Bucket.

530. Single-Stage Impulse Turbine. The absolute velocity of steam entering the buckets is computed from the heat drop and nozzle friction losses. In a

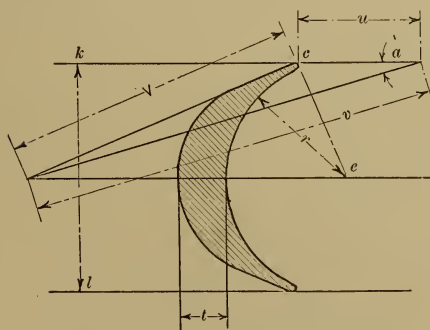

FIG. 253. Art. 530. — Bucket Outline.

turbine of this type, the speed of the buckets can scarcely be made equal to half that of the steam; a more usual proportion is 0.3. The velocity u thus seldom exceeds 1400 ft. per second. Fixing the bucket speed and the absolute entering angle of the steam (usually 20°) we determine graphically the entering angle of the bucket. The bucket may now be designed with equal angles, which would eliminate end thrust if there were no friction, or, allowance being made for

friction, either end thrust or the rotative component of the absolute exit velocity may be eliminated. The normals to the tangents at the edges of the buckets

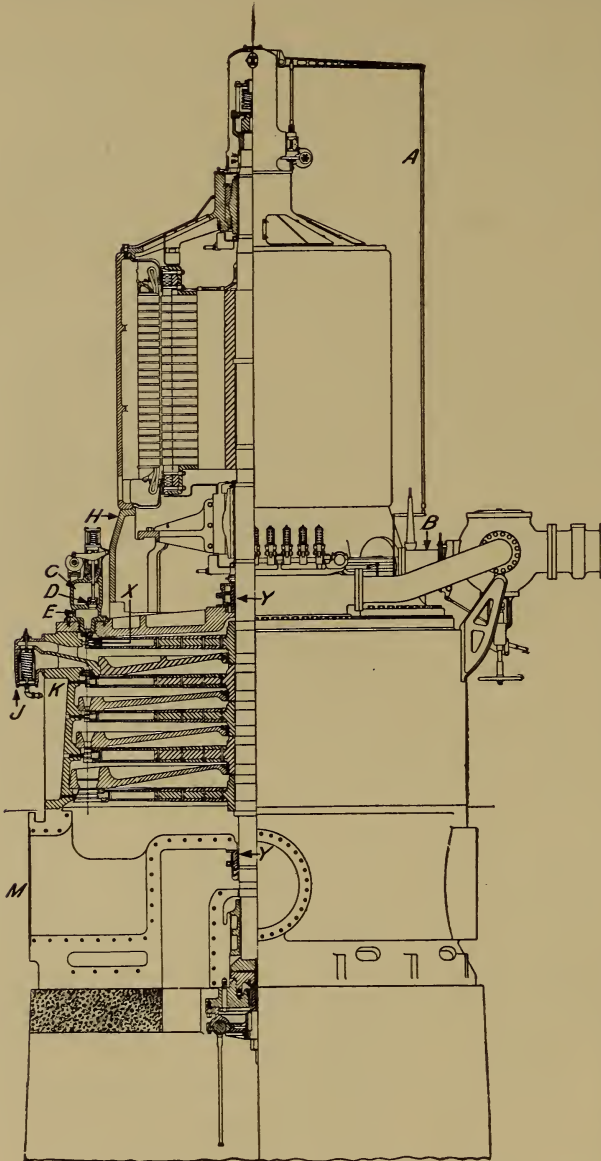

FIG. 254. Art. 531.—Curtis Turbine. (General Electric Company.)

drawn, as *ec*, Fig. 253, the radius *r* is made equal to about $0.965 ec$. The thickness *t* may be made equal to 0.2 times the width *kl*. The bucket as thus drawn is to a scale as yet undetermined; the widths *kl* vary in practice from 0.2 to 1.0 inch. (For a study of steam trajectories and the relation thereof to bucket design, see Roe, *Steam Turbines*, 1911.)

It should be noted that the *back*, rather than the front, of the bucket is made tangent to the relative velocity *V*. The work per pound of steam being computed from the velocity diagram, and the steam consumption estimated for the assumed output, we are now in a position to design the nozzle.

531. Multi-stage Impulse Turbine. If the number of pressure stages is few, as in the Curtis type, the heat drop may be divided equally between the stages. In the Rateau type, with a large number of stages, a proportionately greater heat drop

occurs in the low-pressure stages. The corresponding intermediate pressures are determined from the heat diagram, and the various stages are then designed as

separate single-stage impulse turbines, all having the same rotative speed. The entrance angles of the fixed intermediate blades in the Curtis turbine are equal to those of the absolute exit velocities of the steam. Their exit angles may be adjusted as desired; they may be equal to the entrance angles if the latter are not too acute. The greater the number of pressure stages, the lower is the economical limit of circumferential speed; and if the number of revolutions is fixed, the smaller will be the wheel. Figure 254 shows a form of Curtis turbine, with five pressure stages, each containing two rows of moving buckets. The electric generator is at the top.

532. Problem. *Preliminary Calculations for a Multi-stage Impulse Turbine.*

To design a 1000 (brake) hp. impulse turbine with three pressure stages, having two moving wheels in each pressure stage. Initial pressure, 150 lb. absolute; temperature, 600° F.; final pressure, 2 lb. absolute; entering stream angles, 20°; peripheral velocity, 500 ft. per second; 1200 revolutions per minute.

By reproducing as in Fig. 240 a portion of the Mollier heat chart, we obtain the expansive path *AB*, and the heat drop is $1316.6 - 987.5 = 329.1$ B. t. u. Dividing this into three equal parts, the heat drop per stage becomes $329.1 \div 3 = 109.7$ B. t. u. This is without correction for friction, and we may expect a somewhat unequal division to appear as friction is considered. To include friction in determining the change of condition during flow through the nozzle, we lay off, in Fig. 240, $AH = 109.7$, $HG = \frac{AH}{10}$, and project *GE*, finding $p = 50$, $t = 380^\circ$, at the outlets of the first set of nozzles. The velocity attained (with 10 per cent loss of available heat by friction) is $v = 212.42 \sqrt{109.7} = 2225$ ft. per second.

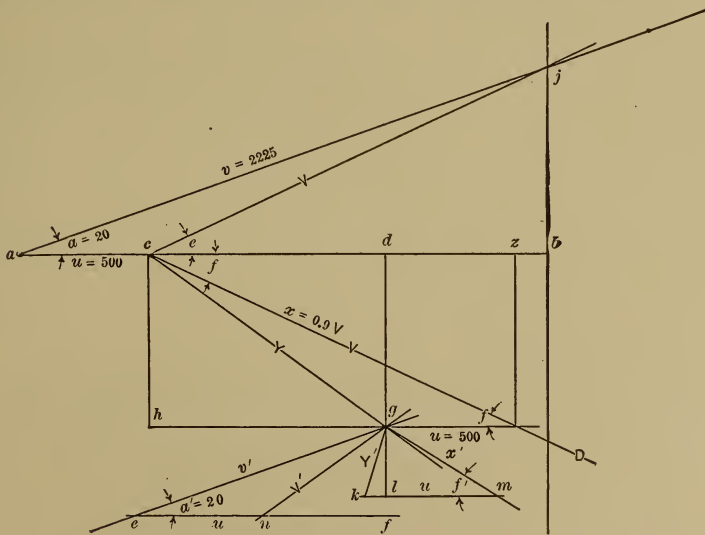

FIG. 255. Art. 532. — Multi-stage Velocity Diagram.

We now lay off the velocity diagram, Fig. 249, making $\alpha = 20^\circ$, $u = 500$, $v = 2225$. The exit velocity x may be variously drawn; we will assume it so that

the relative angles e and f are equal, and, allowing 10 per cent for bucket friction, will make $x = 0.9 V$. For the second wheel, the angle a' is again 20° , while v' , on account of friction along the stationary or guide blades, is $0.9 Y$. After locating V' , if the angles e' and f' were made equal, there would in some cases be a backward impulse upon the wheel, tending to stop it, at the emergence of the jet along Y' . On the other hand, if the angle f' were made too acute, the stream would be unable to get away from the moving buckets. With the particular angles and velocities chosen, some backward impulse is inevitable. We will limit it by making $f' = 30^\circ$. The rotative components of the absolute velocities may be computed as follows, the values being checked as noted from the complete graphical solution of Fig. 255:

$$ab = v \cos 20^\circ = 2225 \times 0.93969 = 2090.81. \quad (2080)$$

$$cd = cz - dz = 0.9 V \cos f - u = 0.9 V \cos e - u = 0.9(2090.81 - 500) - 500 = 931.73. \quad (925)$$

$$ef = eg \cos 20^\circ = 0.9 cg^* \cos 20^\circ = 0.9 \times 1158 \times 0.93969 = 979. \quad (975)$$

$$\begin{aligned} kl &= km - lm = 500 - x' \cos 30^\circ = 500 - 0.9 V' \cos 30^\circ \\ &= 500 - (0.9 \times 596.2 \dagger \times 0.86603) = 36. \end{aligned}$$

The work per pound of steam is then $\left(\frac{ab + cd + ef - kl}{32.2}\right)u = \frac{3966 \times 500}{32.2} = 61500$ foot-pounds, in the first stage. This is equivalent to $61,500 \div 778 = 79.2$ B. t. u. The heat drop assumed for this stage was 109.7 B. t. u. The heat not converted into work exists as residual velocity or has been expended in overcoming nozzle and bucket friction and thus indirectly in superheating the steam. It amounts to $109.7 - 79.2 = 30.5$ B. t. u.

Returning to the construction of Fig. 240, we lay off in Fig. 256 $an = 79.2$ B. t. u. and project no to ko , finding the condition of the steam after passing the first stage buckets. Bucket friction has moved the state point from m to o , at which latter point $Q = 1237.2$, $p = 50$, $t = 414^\circ$. This is the condition of the steam which is to enter the second set of nozzles. These nozzles are to expand the steam down to that pressure at which the ideal (adiabatic) heat drop from the initial condition is $2 \times 109.7 = 219.4$ B. t. u. Lay off $ae = 219.4$, and find the line eg of 12 lb. absolute pressure. Drawing the adiabatic op to intersect eg , we find the heat drop for the second stage, without friction, to be $1237.2 - 1120 = 117.2$ B. t. u., giving a velocity of $212.42\sqrt{117.2} = 2299.66$ ft. per second.

* To find cg , we have

$$cb = V \cos e = 2090.81 - 500 = 1590.81, \quad bj = v \sin a = 2225 \times 0.34202 = 760.99,$$

$$V = \sqrt{cb^2 + bj^2} = \sqrt{1590.81^2 + 760.99^2} = 1765, \quad x = 0.9 V = 0.9 \times 1765 = 1588.5,$$

$$ch = x \sin f = 1588.5 \sin e = 1588.5 \frac{jb}{V} = 1588.5 \frac{760.99}{1765} = 685,$$

$$cg = \sqrt{ch^2 + hg^2} = \sqrt{685^2 + 931.73^2} = 1158.$$

† To find V' , we have

$$gf = v' \sin 20^\circ = 0.9 Y \sin 20^\circ = 0.9 \times 1158 \times 0.34202 = 355,$$

$$nf = ef - u = 979 - 500 = 479, \quad V' = \sqrt{nf^2 + gf^2} = \sqrt{479^2 + 355^2} = 596.2.$$

The complete velocity diagram must now be drawn for the second stage, following the method of Fig. 255. This gives for the rotative components, $ab=2160.97$, $cd=994.87$, $ef=1032.59$, $kl=8.06$. (There is no backward impulse from kl in this case.) The work per pound of steam is

$$\frac{500(2160.97 + 994.87 + 1032.59 + 8.06)}{32.2} = 65,163 \text{ foot-pounds,}$$

or 83.76 B. t. u. Of the available heat drop, 117.2 B. t. u., 33.44 have been expended in friction, etc. Laying off, in Fig. 256, $pq=33.44$, and projecting qr to meet pr , we have r as the state point for steam entering the third set of nozzles. Here $p=12$, $t_1=223^\circ$, $Q'_1=1153.44$. In expanding to the final condenser pressure, the ideal path is rs , terminating at 2 lb. absolute, and giving an uncorrected heat drop of $Q_r - Q_s = 1153.44 - 1039 = 114.44$ B. t. u. The velocity attained is $212.42\sqrt{114.44} = 2271.83$ feet per second. A third velocity diagram shows the work per pound of steam for this stage to be 63,823 foot-pounds, or 82.04 B. t. u. We are not at present concerned with determining the condition of the steam at its exit from the third stage.

The whole work obtained from a pound of steam passing through the three stages is then $79.2 + 83.76 + 82.04 = 245.0$ B. t. u. (20a). The horse power required is 1000 at the brake or say $1000 \div 0.8 =$

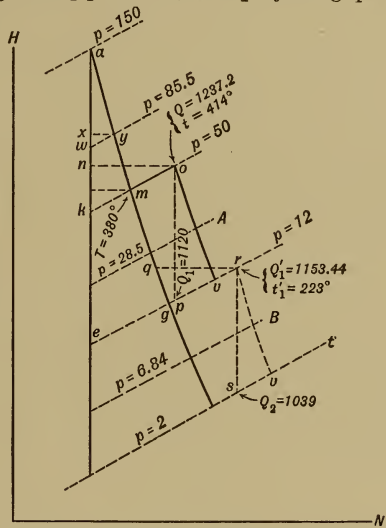

FIG. 256. Art. 532.—Steam Path, Multi-stage Turbine.

1250 hp. at the buckets. This is equivalent to $1250 \times \frac{1980000}{778} = 3,181,250$ B. t. u. per hour. The pounds of steam necessary per hour are $3,181,250 \div 245.0 = 12,974$. This is equivalent to 10.38 lb. per brake hp.-hr., a result sufficiently well confirmed by the test results given in Chapter XV.

Proceeding now to the nozzle design, we adopt the formula $F = \frac{GW}{V}$ from Art.

521. It will be sufficiently accurate to compute cross-sectional areas at throats and outlets only. The path of the steam, in Fig. 256, is as follows: through the first set of nozzles, along am ; through the corresponding buckets, along mo ; thence alternately through nozzles and buckets along ou , ur , rv , vt . The points u , v , etc., are found as in Fig. 240. It is not necessary to plot accurately the whole of the paths am , ou , rv ; but the condition of the steam must be determined, for each nozzle, at that point at which the pressure is 0.57 the initial pressure (Art. 522). The three initial pressures are 150, 50, and 12; the corresponding throat pressures are 85.5, 28.5, and 6.84. Drawing these lines of pressure, we lay off, for example, $wx = \frac{1}{10}aw$, project xy to wy , and thus determine the state y at the throats of the

first set of nozzles. The corresponding states are similarly determined for the other nozzles. We thus find,

at y , $p = 85.5$, $t = 474^\circ$, $q = 1260.5$;	at m , $p = 50$, $t = 380^\circ$, $q = 1217.87$;
at A , $p = 28.5$, $t = 313^\circ$, $q = 1192$;	at u , $p = 12$, $x = 0.989$, $q = 1131.72$;
at B , $p = 6.84$, $x = 0.9835$, $q = 1118$;	at v , $p = 2$, $x = 0.932$, $q = 1050.44$.

We now tabulate the corresponding velocities and specific volumes, as below. The former are obtained by taking $V = 223.8 \pm \sqrt{q_1 - q_2}$; the latter are computed from the Tumlirz formula, $W = 0.5963 \frac{T}{P} - 0.256$. Thus, at the throat of the first nozzle,

$$V = 223.84 \sqrt{1316.6 - 1260.5} = 1683; \text{ while } W = 0.5963 \frac{460 + 474}{85.5} - 0.256 = 6.26.$$

In the wet region, the Tumlirz formula is used to obtain the volume of *dry* steam at the stated pressure and the tabular corresponding temperature; this is applied to the wet vapor: $W_w = 0.017 + x(W_0 - 0.017)$. The tabulation follows.

At y , $V = 1683$, $W = 6.26$;	at m , $V = 2225$, $W = 9.724$;
at A , $V = 1507$, $W = 15.92$;	at u , $V = 2299$, $W = 32.24$;
at B , $V = 1330$, $W = 53.92$;	at v , $V = 2271$, $W = 162.62$.

The value of G , the weight of steam flowing per second, is $12,974 \div 3600 = 3.604$ lb. For reasonable proportions, we will assume the number of nozzles to be 16 in the first stage, 42 in the second, and 180 in the third. The values of G per nozzle for the successive stages are then $3.604 \div 16 = 0.22525$, $3.604 \div 42 = 0.08581$ and $3.604 \div 180 = 0.02002$. We find values of F as follows :

$$\begin{aligned} \text{At } y, \frac{0.22525 \times 6.26}{1683} &= 0.000839; & \text{at } u, \frac{0.08581 \times 32.24}{2299} &= 0.001205; \\ \text{at } m, \frac{0.22525 \times 9.724}{2225} &= 0.000989; & \text{at } B, \frac{0.02002 \times 53.92}{1330} &= 0.000809; \\ \text{at } A, \frac{0.08581 \times 15.92}{1507} &= 0.000903; & \text{at } v, \frac{0.02002 \times 162.62}{2271} &= 0.00144. \end{aligned}$$

Completing the computation as to the last set of nozzles only, the throat area is 0.000809 sq. ft., that at the outlet being 0.00144 sq. ft. These correspond to diameters of 0.385 and 0.515 in.

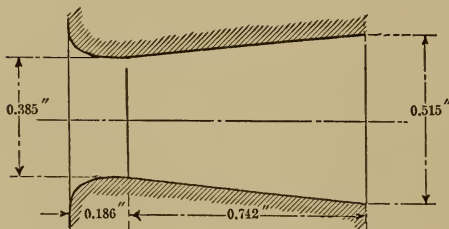

FIG. 257. Art. 532. — Third Stage Nozzle.

The taper may be uniform from throat to outlet, the sides making an angle of 10° . This requires a length from throat to outlet of $(0.515 - 0.385) \div 2 \tan 5^\circ = 0.742$ in. The length from inlet to throat may be one fourth this, or 0.186 in., the edge of the inlet being rounded. The nozzle is shown in Fig. 257.

The diameter of the bucket wheels at mid-height is obtained from the rotative speed and peripheral velocity. If d be the diameter,

$$3.1416 d \times 1200 = 60 \times 500, \text{ or } d = 7.98 \text{ feet.}$$

The forms of bucket are derived from the velocity diagrams. For the first stage, we proceed as in Art. 530, using the *relative angles* e and f given in Fig. 255 for determining the angles of the backs of the moving blades, and the *absolute angles* for determining those of the stationary blades.

533. Utilization of Pressure Energy. Besides the energy of impulse against the wheel, unaccompanied by changes in pressure, the steam may expand while traversing the buckets, producing work by reaction. This involves incomplete expansion in the nozzle, and makes the velocities of the discharged jets much less than in a pure impulse turbine. Lower rotative speeds are therefore practicable. Loss of efficiency is avoided by carrying the ultimate expansion down to the condenser pressure. In the pure pressure turbine of Parsons, there are no expanding nozzles; *all* of the expansion occurs in the buckets (Art. 524). (See Fig. 247.) Here the whole useful effort is produced by the reaction of the expanding steam as it emerges from the working blades to the guide blades. No velocity is given up during the passage of the steam; the velocity is, in fact, increasing, hence the name **reaction turbine**. The **impulse turbine**, on the contrary, performs work solely because of the force with which the swiftly moving jet strikes the vane. It is sometimes called the **velocity turbine**. Turbines are further classified as **horizontal** or **vertical**, according to the position of the shaft, and as **radial flow** or **axial flow**, according to the location of the successive rows of buckets. Most pressure turbines are of the axial flow type.

534. Design of Pressure Turbine. The number of stages is now large. The heat drop in any stage is so small that the entering velocity is no longer negligible. The velocity of the steam will increase continually throughout the machine, being augmented by expansion more rapidly than it is decreased by friction. If the effective velocity at entrance to a row of moving blades is V_1 , increasing to V_2 by reason of expansion occurring in the blades, the energy of reaction, available for performing work, is $\frac{V_2^2 - V_1^2}{2g}$. The effective velocity entering the stationary blades being V_3 , and increasing to V_4 by expansion therein, energy is produced equal to $\frac{V_4^2 - V_3^2}{2g}$, which is given up to the following set of moving blades, in the shape of an impulse. Each moving blade thus receives an impulse at its entrance end and a reaction at its outlet end. By making the forms and angles of fixed and moving blades the same, the work done by impulse equals the work done by reaction, or

$$\frac{V_2^2 - V_1^2}{2g} = \frac{V_4^2 - V_3^2}{2g}.$$

In Fig. 259, lay off the horizontal distance FO , representing the aggregate axial length of four drums composing a pressure turbine. The peripheral speeds of drums vary from 100 to 350 ft. per sec., increasing as the pressure decreases and

withstanding friction, to make the *relative exit* and *absolute entrance* angles and velocities about equal. (This equalizes the amounts of work done by impact and by reaction.) In such case, we have the simple graphical construction of Fig. 260.

Since $ab=bc$, $db=be$, and $ad=ec$, we obtain

$$\text{work} = \frac{u(ah+he)}{32.2} = \frac{ad(hc+hd)}{32.2}.$$

Drop the perpendicular bh , and with h as a center describe the arc aj . Draw dg perpendicular to ac . Then

$$\overline{dg}^2 = ad \times dc = ad(dh+hc), \text{ and}$$

$$\text{work} = \frac{\overline{dg}^2}{32.2} \text{ foot-pounds, or } \left(\frac{dg}{158.3}\right)^2 \text{ B. t. u.}$$

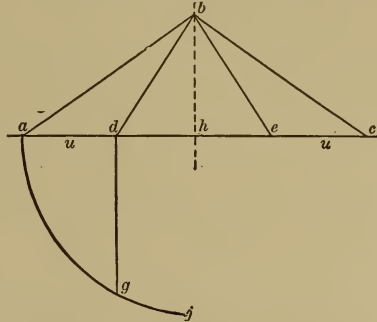

FIG. 260. Art. 534, Prob. 18. — Velocity Diagram, Pressure Turbine.

This result represents the heat converted into work at a stage located vertically in line with the point G , Fig. 259. Let this heat be laid off to some convenient scale, as GH . Similar determinations for other states give the *heat drop curve* $IJKHLMNOP$. The average ordinate of this curve is the average heat drop or work done per stage. If we divide the total heat drop obtained by the average drop per stage, we have the *number of stages*, the nearest whole number being taken.*

Suppose the machine to be required to drive a 2000 kw. generator (2400 kw. overload capacity) at 175 lb. initial absolute pressure and 50° of superheat, the condenser pressure being 1 lb. absolute, the r. p. m. 3600, the generator efficiency 0.94 and the losses as follows: steam friction, 0.25; leakage, 0.06; windage and bearings, 0.16; residual velocity in exhaust, 0.03. The theoretical heat drop is $1227-890=337$ B. t. u. The drop corrected for steam friction is $337 \times 0.75=253$ B. t. u. The average ordinate of the heat drop curve in Fig. 259 being 4.16 B. t. u., the corrected number of stages is $\frac{253}{4.16}=61$ (nearest whole number) instead of 60. The curve of heat drops may now

be corrected for the necessary revised numbers of stages in the various drums: thus, the whole heat drop being 253 B. t. u., that in the first drum must be $\frac{253}{6}=42.2$ B. t. u. The average heat drop per stage for the first drum being (average ordinate of IJ) 1.56 B. t. u., the number of stages on that drum is $\frac{42.2}{1.56}=27$ (instead of 26).

For the other drums, proceeding in the same way, the numbers of stages work out as before, 16, 10 and 8.

The aggregate of losses exclusive of steam friction is 0.25. The heat available for producing power is then $253 \times 0.75=190$ B. t. u. per lb. of steam. With the given generator efficiency, the weight of steam required per kw.-hr. is

$$\frac{2545 \times 1.34}{190 \times 0.94} = 19.0.$$

* Dividing the total heat drop at a state in a vertical line through C by the average drop per stage from F to C , we have the number of stages on the first drum.

At normal rate, the weight of steam used at the overload condition is

$$\frac{19.0 \times 2400}{3600} = 12.67 \text{ lb. per sec.}$$

535. Specimen Case. To determine the general characteristics of a pressure turbine operating between pressures of 100 and 3.5 lb., with an initial superheat of 300° F., the heat drop being reduced 25 per cent by friction. There are to be 3 drums, and the heat drop is to be equally divided between the drums. The peripheral speeds of the successive drums are 160, 240, 320 ft. per second. The relative entrance and absolute exit velocities and angles are equal; the absolute entrance angle is 20°. The turbine makes 3000 r. p. m. and develops 2500 kw. with losses between buckets and generator output of 65 per cent.

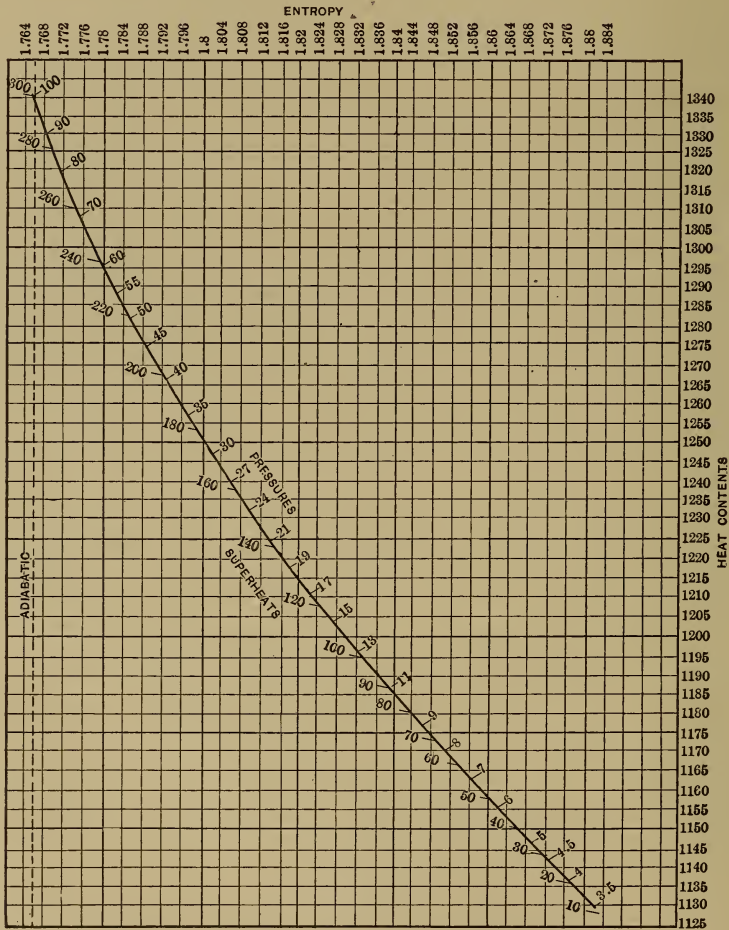

FIG. 260 a. Art. 535. — Expansion Path, Pressure Turbine.

In Fig. 260 *a*, the expansive path is plotted on a portion of the total heat-entropy diagram. The total heat drop is shown to be $1342 - 1130 = 212$ B. t. u., and the heat drop per drum is $212 \div 3 = 70\frac{2}{3}$ B. t. u. In Fig. 260 *b*, lay off to any scale the equal distances *ab*, *bc*, *cd*, and the vertical distances *ae*, *bg*, *ci*, representing the drum speeds. Lay off also *ak*, *bm*, *co*, equal respectively to $1\frac{1}{3} \times (ae, bg, ci)$, and *al*, *bn*, *cp*, equal respectively to $3\frac{1}{3}$ times these drum speeds. The curve *qr*

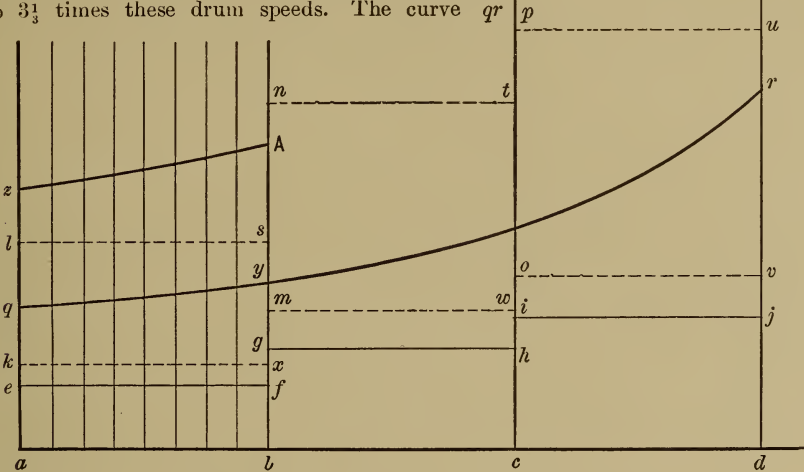

FIG. 260 *b*. Art. 535. — Elements of Pressure Turbine.

of entrance absolute velocities is now assumed, so as to lie wholly within the area *klstnpwovomx*. Figure 260 *c* shows the essential parts of the velocity diagram for the stages on the first drum. Here *ab* represents *aq* in Fig. 260 *b*, *ad* represents *ae*, the angle *bad* is 20° , and $\left(\frac{de}{158.3}\right)^2 = \left(\frac{279.7}{158.3}\right)^2 = 3.12$ B. t. u. is the heat drop for the first stage in the turbine. Making *ac* represent *by* and drawing *dc*, *ch*, *af*, we find $\left(\frac{df}{158.3}\right)^2 = \left(\frac{304.7}{158.3}\right)^2 = 3.70$ B. t. u. as the heat drop for the last stage on the first drum. For intermediate stages between these two, we find,

INITIAL ABSOLUTE VELOCITY	ORDINATE FROM <i>d</i>	HEAT DROP, B. T. U.
<i>ab</i> = 350	<i>de</i> = 279.7	3.12
356 $\frac{1}{4}$	282.8	3.20
362 $\frac{1}{2}$	285.9	3.26
368 $\frac{3}{4}$	289.0	3.34
375	292.1	3.40
381 $\frac{1}{4}$	295.3	3.48
387 $\frac{1}{2}$	298.4	3.56
393 $\frac{3}{4}$	301.5	3.63
<i>ac</i> = 400	<i>df</i> = 304.7	3.70

In the first stage of the first drum, the condition of the steam at entrance to the guide blades is (Fig. 260 *a*) $H=1342$, $p=100$; at exit from the moving blades, it is $H=1338.59$, $p=98$. From the total heat-pressure diagram, or by computation, the corresponding specific volumes are 6.5 and 6.6. The volumes of steam flowing are then $6.5 \times 17.1 = 111$ and $6.6 \times 17.1 = 113$ cu. ft. per second. The absolute steam velocities are (Fig. 260 *b*) 350 and $356\frac{1}{4}$ ft. per second. The axial components of these velocities (entrance angle 20°) are $0.34202 \times 350 = 120$, and $0.34202 \times 356\frac{1}{4} = 122$. The drum periphery is $1.02 \times 3.1416 = 3.2$ ft. If the blade thicknesses occupy $\frac{1}{3}$ this periphery and the width for steam passage between the buckets is constant, the width for passage of steam is $\frac{2}{3} \times 3.2 = 2.133$ ft., and the necessary height of fixed buckets is $\frac{111}{2.133 \times 120} = 0.434$ ft. or 5.2 in. at the beginning of the stage and $\frac{113}{2.133 \times 122} = 0.434$ ft. or 5.2 in. at the end. The fixed blade angles are determined by the velocities be and ab , Fig. 260; those of the moving blades by bd and bc . There is no serious error involved in taking the velocity and specific volume as constant throughout a blade. The height of the moving buckets should of course not be less than that of the guide blades; this may be accomplished by increasing the thickness of the former. The blade heights should be at least 3 per cent of the drum diameter, if excessive leakage over tips is to be avoided. The clearance over tips varies from 0.008 to 0.01 inch per foot of drum diameter. Blade widths vary from $\frac{3}{8}$ to $1\frac{1}{4}$ in., with center-to-center spacing from $1\frac{1}{3}$ to 4 ins.

The method of laying out the blades is suggested in Fig. 260 *d*. Let ab be the absolute steam velocity at entrance to a row of moving blades, cb the blade velocity. Then the relative velocity ac determines the entering angles at c and e . The moving blade is made with a long straight tapering tail, in which expansion occurs after the steam passes the point r . Let hj , parallel with the center line of the expanding portion of the blade (fg), represent the velocity attained at the outlet of this blade, and let jk again represent the blade velocity. Then hk represents the absolute velocity of exit and determines the entering angles of the following fixed blades, on and ml being parallel with hk . Finally, since the steam must emerge from the fixed blades with a velocity parallel with ab , we draw pq parallel with ab , determining the direction of the expanding position (beyond s) of the fixed blade. The angles abc and hjk are made equal, and range between 20° and 30° .

It should be noted that the velocities indicated by the curve qr , Fig. 260 *b*, are those of the steam at exit from the fixed blades and entrance to the moving blades. The diagram of Fig. 260 gives the absolute velocity of the steam entering the *next set* of fixed blades.

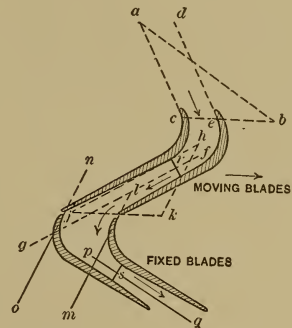

FIG. 260 *d*. Art. 535.—Blading of Pressure Turbine.

COMMERCIAL FORMS OF TURBINE.

536. De Laval; Stumpf. Figure 235 illustrates the principle of the De Laval machine, the working parts of which are shown in Fig. 261. Entering through divergent nozzles, the steam strikes the buckets around the periphery of the wheel b . The shaft c transmits power through the helical pinions a, a , which drive the gears e, e, e, e , on the working shafts f, f . The wheel is housed with the iron cas-

ing *g*. This is a horizontal single-stage impulse turbine with a single wheel. Its rotative speed is consequently high; in small units, it reaches 30,000 r. p. m. It is

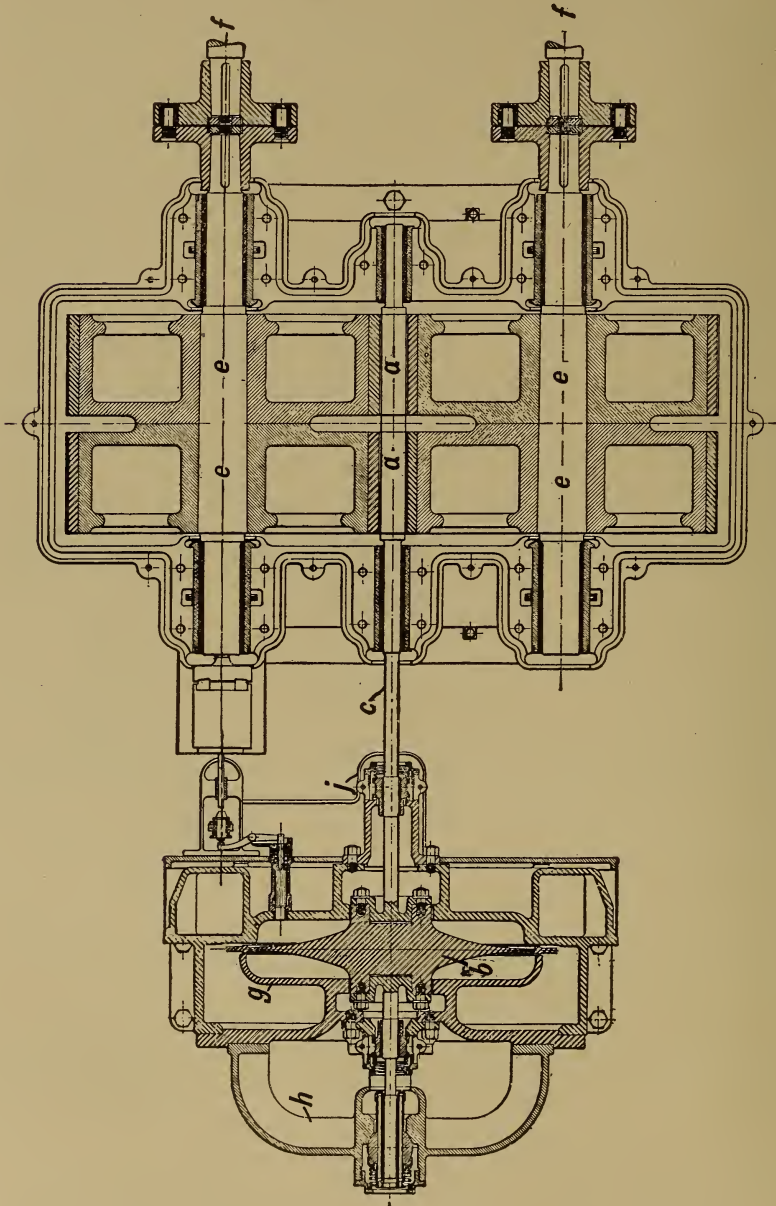

FIG. 261. Art. 536. — De Laval Turbine.

built principally in small sizes, from 5 to 300 h.p. The nozzles make angles of 20° with the plane of the wheel; the buckets are symmetrical, and their angles

range from 32° to 36° , increasing with the size of the unit. For these proportions, the most efficient values of u would be about 950 and 2100 for absolute steam velocities of 2000 and 4400 feet per second, respectively; in practice, these speeds are not attained, u ranging from 500 to 1400 feet per second, according to the size. The high rotative speeds require the use of gearing for most applications. The helical gears used are quiet, and being cut right- and left-hand respectively they practically eliminate end thrust on the shaft. The speed is usually reduced in the proportion of 1 to 10. The high rotative speeds also prevent satisfactory balancing, and the shaft is, therefore, made flexible; for a 5-hp. turbine, it is only $\frac{3}{4}$ inch in diameter. The bearings h, j are also arranged so as to permit of some movement. The pressure of steam in the wheel case is that of the atmosphere or condenser, all expansion occurring in the nozzle. A centrifugal governor controls the speed by throttling the steam supply and by opening communication between the wheel case and atmosphere when necessary.

The nozzles of the De Laval turbine are located as in Fig. 235. Those of the Stumpf, another turbine of this class, are tangential, while the buckets are of the Pelton form (Fig. 252), and are milled in the periphery of the wheel. A very large wheel is employed, the rotative speeds being thus reduced. In a late form of the Stumpf machine, a second stage is added. The reversals of direction are so extreme that the fluid friction must be excessive.

537. Curtis Turbine. This is a multi-stage impulse turbine, the principle of operation having been shown in Fig. 245. In most cases, it is vertical; for marine

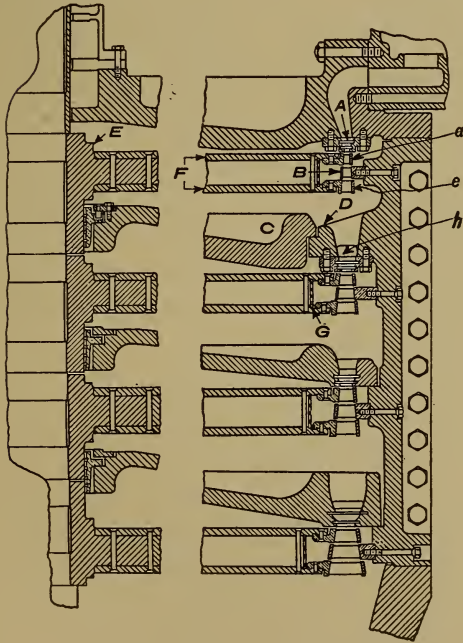

FIG. 262. Art. 537. — Curtis Turbine.

applications, it is necessarily made horizontal. Figure 262 illustrates the stationary and moving blades and nozzles. Steam enters through the nozzle A , strikes a row of moving vanes at a , passes from them through stationary vanes B to another row of moving vanes at e , then passes through a second set of expanding nozzles at h to the next pressure stage. This particular machine has four pressure stages with two sets of moving buckets in each stage. The direction of flow is *axial*. The number of pressure stages may range from two to seven. From two to four velocity stages (rows of moving buckets) are used in each pressure stage. In the two-stage machine, the second stage is disconnected when the turbine runs non-condensing, the exhaust from the first stage being discharged to the atmosphere. Governing is effected

by automatically varying the number of nozzles in use for admitting steam to the first stage. A step bearing carries the whole weight of the machine, and must be supplied with lubricant under heavy pressure; an hydraulic accumulator system is commonly employed.

538. Rateau Turbine. This is a horizontal, axial flow, multi-stage impulse turbine. The number of pressure stages is very large — from twenty-five upward. There is one velocity stage in each pressure stage. Very low speeds are, therefore, possible. Figure 263 shows the general arrangement; the transverse partitions *e, e* form cells, in which revolve the wheels *f, f*; the nozzles are merely slots in the partitions. The blades are pressed out of sheet steel and riveted to the wheel. The wheels themselves are of thin pressed steel.

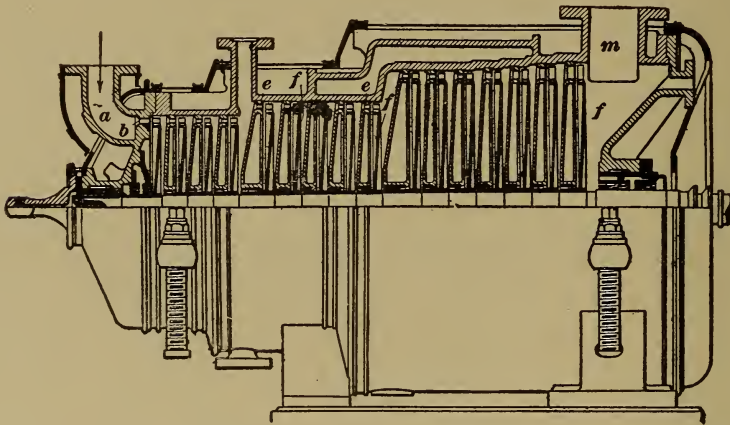

FIG. 263. Art. 538. — Rateau Turbine.

539. Westinghouse-Parsons Turbine. This is of the axial flow pressure type, and horizontal. The steam expands through a large number of successive fixed and moving blades. In Fig. 264, the steam enters at *A* and passes along the various blades toward the left; the movable buckets are mounted on the three drums, and the fixed buckets project inward from the casings. The diameters of the drums increase by steps; the increasing volume of the steam within any section is accommodated by varying the bucket heights. The balance pistons *P, P, P* are used to counteract end thrust. The speed is fairly high, and special provision must be made for it in the design of the bearings. Governing is effected by intermittently opening the valve *V*; this valve is wide open whenever open at all.

The length of this machine is sometimes too great for convenience. To overcome this, the "double-flow" turbine receives steam near its center, through expanding nozzles which supply a simple Pelton impulse wheel. This utilizes a large proportion of the energy, and the steam then flows in both directions axially, through a series of fixed and moving expanding buckets. Besides reducing the length, this arrangement practically eliminates end thrust and the necessity for balance pistons.

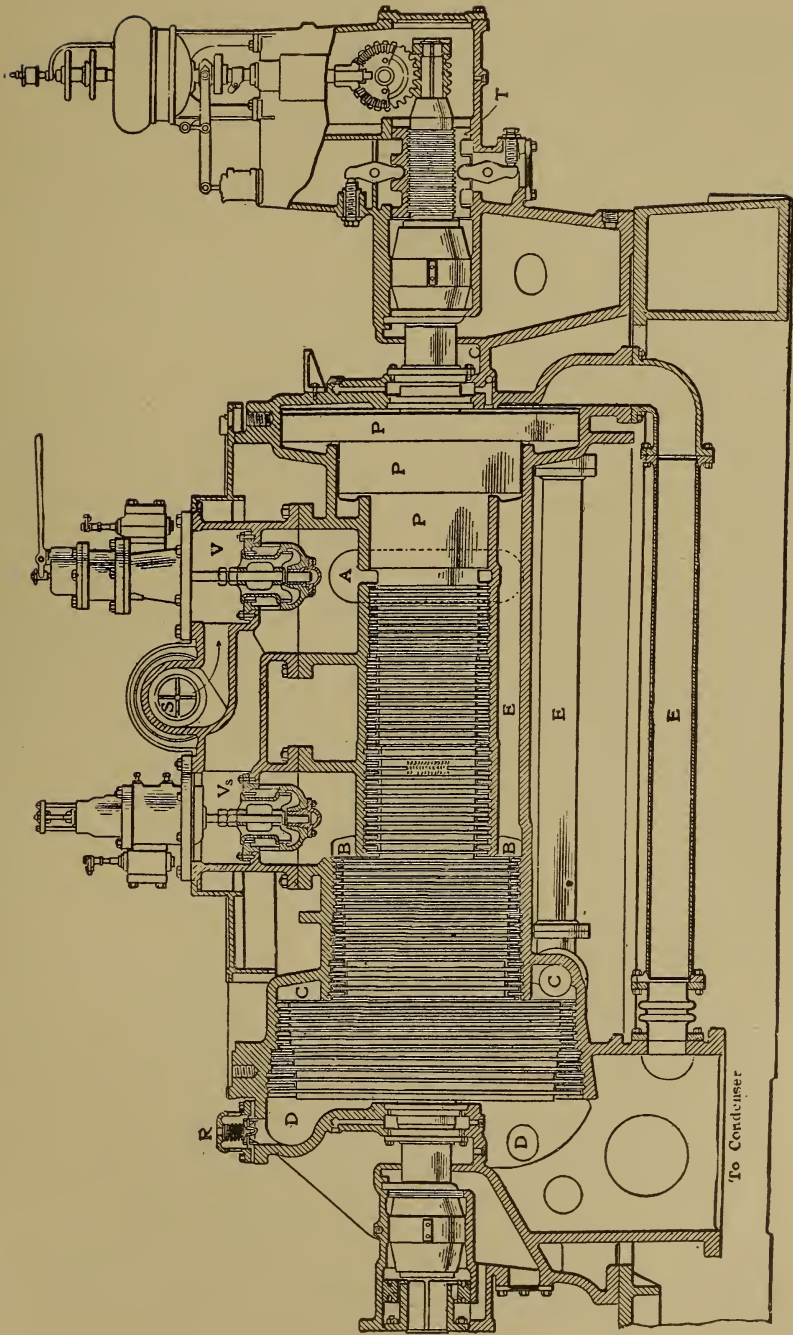

FIG. 264. Art. 539. — Westinghouse-Parsons Turbine.

540. Applications of Turbines. Turbo-locomotives have been experimented with in Germany; the direct connection of the steam turbine to high-pressure rotary air compressors has been accomplished. In stationary work, the direct driving of generators by turbines is common, and the high rotative speeds of the latter have cheapened the former. At high speeds, difficulties may be experienced with commutation; so that the turbine is most successful with alternating-current machines. When driving pumps, turbines permit of exceptionally high lifts with good efficiencies for the centrifugal type, and low first costs. For low-pressure, high-speed blowers, the turbine is an ideal motor. (See Art. 239.) The outlook for a *gas* turbine is not promising, any gas cycle involving combustion at constant pressure being both practically and thermodynamically inefficient.

The objections to the turbine in marine application have arisen from the high speed and the difficulty of reversing. A separate reversing wheel may be employed, and graduation of speed is generally attained by installing turbines in pairs. A small reciprocating engine is sometimes employed for maneuvering at or near docks. Since turbines are not well adapted to low rotative speeds, they are not recommended for vessels rated under 15 or 16 knots. The advantages of turbo-operation, in decreased vibration, greater simplicity, smaller and more deeply immersed propellers, lower center of gravity of engine-room machinery, decreased size, lower first cost, and greater unit capacity without excessive size, have led to extended marine application. The most conspicuous examples are in the Cunard liners *Lusitania* and *Mauretania*. The former has two high-pressure and two low-pressure main turbines, and two astern turbines, all of the Parsons type (22). The drum diameters are respectively 96, 140, and 104 in. An output of 70,000 hp. is attained at full speed.

541. The Exhaust-steam Turbine. From the heat chart, Fig. 177, it is obvious that steam expanding adiabatically from 150 lb. absolute pressure and 600° F. to 1.0 lb. absolute pressure transforms into work 365 B. t. u. It has been shown that in the ordinary reciprocating engine such complete expansion is undesirable, on account of condensation losses. The final pressure is rarely below 7 lb. absolute, at which the heat converted into work in the above illustration is only 252 B. t. u. The turbine is particularly fitted to utilize the remaining 113 B. t. u. of available heat. The use of low-pressure turbines to receive the exhaust steam from reciprocating engines, has, therefore, been suggested. Some progress has been made in applying this principle in plants where the engine load is intermittent and condensation of the exhaust would scarcely pay. With steel mill engines, steam hammers, and similar equipment, the introduction of a low-pressure turbine is decidedly profitable. The variations in supply of steam to the turbine are offset by the use of a *regenerator* or *accumulator*, a cast-iron, water-sprayed chamber having a large storage capacity, constituting a "fly wheel for heat," and by admitting live steam to the turbine through a reducing valve. When a surplus of steam reaches the accumulator, the pressure rises; as soon as this falls, some of the water is evaporated. The maximum pressure is kept low to avoid back pressure at the engines. A steam consumption by the turbine as low as 35 lb. per brake hp.-hr. has been claimed, with 15 lb. initial absolute pressure and a final vacuum of 26 in. Other good results have been shown in various trials (23). (See Art. 552.) Wait (24) has described a plant at South Chicago, Ill., in

which a 42 by 60 inch double cylinder, reversible rolling-mill engine exhausts to an accumulator at a pressure 2 or 3 lb. above that of the atmosphere. This delivers steam at about atmospheric pressure to a 500 kw. Rateau turbine operated with a 28-in. vacuum. The steam consumption of the turbine was about 35 lb. per electrical hp.-hr., delivered at the switchboard.

The S.S. *Turbinia*, in 1897, was fitted with low-pressure turbines receiving the exhaust from reciprocating engines and operating between 9 lb. and 1 lb. absolute. One third of the total power of the vessel was developed by the turbines, although the initial pressure was 160 lb.

542. Commercial Considerations. The best turbines, in spite of their thermodynamically superior cycle, have not yet equalled in thermal efficiency the best reciprocating engines, both operating at full load. (This refers to work at the cylinder. The heat consumption referred to work at the shaft has probably been brought as low, with the turbine, as with any form of reciprocating engine.) The combination of reciprocating engine and turbine (Art. 552) has probably given the lowest consumption ever reported for a vapor engine. The average turbine is more economical than the average engine; and since the mechanical and fluid friction losses are disproportionately large, it seems reasonable to expect improved efficiencies as experimental knowledge accumulates.

The turbine is cheaper than the engine; it weighs less, has no fly wheel, requires less space and very much less foundation. It can be built in larger units than a reciprocating cylinder. Power house buildings are cheapened by its use; the cost of attendance and of sundry operating supplies is reduced. It probably depreciates less rapidly than the engine. The wide range of expansion makes a high vacuum desirable; this leads to excessive cost of condensing apparatus. Similarly, superheat is so thoroughly beneficial in reducing steam friction losses that a considerable investment in superheaters is necessary. The choice as between the turbine and the engine must be determined with reference to all of the conditions, technical and commercial, including that of *load factor*. Turbine economy cannot be measured by the indicator, but must be determined at the brake or switchboard, and should be expressed on the heat unit basis (B. t. u. consumed per unit of output per minute).

For results of trials of steam turbines, see Chapter XV.

(1) *Trans. Inst. Engrs. and Shipbuilders in Scotland*, XLVI, V. (2) Berry, *The Temperature-Entropy Diagram*, 1905. (2 a) For the general theory of fluid flow, see Cardullo, *Practical Thermodynamics*, 1911, Arts. 55-60; Goodenough, *Principles of Thermodynamics*, 1911, Arts. 148-150, 153; for empirical formulas, see Goodenough, *op. cit.*, Art. 154. (3) To show this, put the expression in the brace equal to m , and make $\frac{dm}{dp}=0$; then $\frac{P}{p} = \left(\frac{y+1}{2}\right)^{\frac{y}{1-y}}$, which may be solved for any given value of y . (4) *Thesis*, Polytechnic Institute of Brooklyn, 1905. (5) Thomas, *Steam Turbines*, 1906, 89. (6) *Proc. Inst. Civ. Eng.*, CXL, 199. (7) *Zeits. Ver. Deutsch. Ing.*, Jan. 16, 1904. (8) Rankine, *The Steam Engine*, 1897, 344. (9) *Experimental Researches on the Flow of Steam*, Brydon tr.; Thomas, *op. cit.*, 106. (10) Thomas, *op. cit.*, 123. (11) *Engineering*, XIII (1872). (12) *Trans. A. S. M. E.*, XI, 187. (13) *Mitteil. über Forschungsarb.*, XVIII, 47. (14) *Practice and Theory of the Injector*, 1894. (15) Peabody, *Thermodynamics*, 1907, 443.

(16) *Trans. A. S. M. E.*, XXVII, 081. (17) Stodola, *Steam Turbines*. (18) *The Steam Engine*, 1905, I, 170. (19) *Technical Thermodynamics*, Klein tr., 1907: I, 225; II, 153. (20) *Trans. A. S. M. E.*, XXVII, 081. (20 a) For a method for equalizing the three quantities of work, see Cardullo's paper, "Energy and Pressure Drop in Compound Steam Turbines," *Jour. A. S. M. E.*, XXXIII, 2. (21) See H. F. Schmidt, in *The Engineer* (Chicago), Dec. 16, 1907; *Trans. Inst. Engrs. and Shipbuilders in Scotland*, XLXIX. (22) *Power*, November, 1907, 770. (23) *Trans. A. S. M. E.*, XXV, 817; *Ibid*, XXXII, 3, 315. (24) *Proc. A. I. E. E.*, 1907.

OUTLINE OF CHAPTER XIV

The turbine utilizes the velocity energy of a jet or stream of steam.

Expansion in a nozzle is adiabatic, but not isentropic; the losses in a turbine are due to residual velocity, friction of steam through nozzles and buckets and mechanical friction.

$$E + PW + \frac{V^2}{2g} = e + pw + \frac{v^2}{2g}, \text{ or } \frac{V^2}{2g} = q - Q, \text{ approximately;}$$

$$\text{whence } V = 223.84 \sqrt{q - Q}.$$

The complete expansion secured in the turbine warrants the use of exceptionally high vacuum.

Nozzle friction decreases the heat converted into work and the velocity attained; $V = 212.42 \sqrt{q - Q}$.

The heat expended in overcoming friction reappears in drying or superheating the steam.

$F = G \frac{W}{V}$, which reaches a minimum at a definite value of $\frac{P}{p}$. For steam, this value is about 0.57. If the discharge pressure is less than $0.57p$, the nozzle converges to a "throat" and afterward diverges.

The multi-stage impulse turbine uses lower rotative speeds than the single stage.

The diverging sides of the nozzle form an angle of 10° ; the converging portion may be one fourth as long.

Steam consumption per Ihp.-hr. = $2545 \div E(q - Q)$.

The rotative components of the absolute velocities determine the work; the relative velocities determine the (moving) bucket angles. Bucket friction may decrease relative velocities by 10 per cent during passage. $\text{Work} = (v \cos \alpha \pm Y \cos \beta) \frac{u}{g}$.

Efficiency = $E = \text{Work} \div 778(q - Q)$. Bucket angles may be adjusted to equalize end thrust, to secure maximum work, or may be made equal.

For a right-angled stream change, maximum efficiency is 0.50; with complete reversal, it is 1.00. With practicable buckets, it is always less than 1.0.

The backs of moving buckets are made tangent to the relative stream velocities.

The angles of fixed blades are determined by the absolute velocities.

In the pure pressure turbine, expansion occurs in the buckets. No nozzles are used.

Turbines may be horizontal or vertical, radial or axial flow, impulse or pressure type.

In designing a pressure turbine, $\frac{u}{v} = 0.33$ to 0.67 . The heat drop at any stage may

equal $\left(\frac{dg}{158.3}\right)^2$, Fig. 260. The number of stages is the quotient of the whole heat

drop, corrected for friction; by the mean value of this quantity. Friction through buckets may be from 20 to 30 per cent. The accumulated heat drop to any stage is ascertained and the condition of the steam found as in Fig. 240. Typical design, Arts. 534, 535.

Commercial forms include the De Laval, single-stage impulse :

Stumpf, single- or two-stage impulse, with Pelton buckets.

Curtis, multi-stage impulse, usually vertical, axial flow.

Rateau, multi-stage impulse, axial flow, horizontal, many stages.

Westinghouse-Parsons, pressure type, axial flow, horizontal ; sometimes of the "double flow" form.

Marine applications involve some difficulty, but have been satisfactory at high speeds.

The turbine may utilize economically the heat rejected by a reciprocating engine. A regenerator is sometimes employed.

The best recorded thermal economy has been attained by the reciprocating engine ; but commercially the turbine has many points of superiority.

PROBLEMS

1. Show on the *TV* diagram the ideal cycle for a turbine operating between pressure limits of 140 lb. and 2 lb., with an initial temperature of 500° F. and adiabatic (isentropic) expansion. What is the efficiency of this cycle ?

(*Ans.*, efficiency is 0.24.)

2. In Problem 1, what is the loss of heat contents and the velocity ideally attained ?

3. In Problem 1, how will the efficiency and velocity be affected if the initial pressure is 150 lb.? If the initial temperature is 600° F.? If the final pressure is 1 lb.?

4. Solve Problems 1, 2, and 3, making allowance for friction as in Art. 519.

5. Compute analytically, in Problem 3, first case, the condition of the steam after expansion, as in Art. 520, assuming the heat drop to have been decreased 10 per cent by friction. (*Ans.*, dryness=0.877.)

6. An ideal reciprocating engine receives steam at 150 lb. pressure and 550° F., and expands it adiabatically to 7 lb. pressure. By what percentage would the efficiency be increased if the steam were afterward expanded adiabatically in a turbine to 1.5 lb. pressure. (*Ans.*, 47 per cent.)

7. Steam at 100 lb. pressure, 92 per cent dry, expands to 16 lb. pressure. The heat drop is reduced 10 per cent by friction. Compute the final condition and the velocity attained. (*Ans.*, dryness=0.846 ; velocity=2375 ft. per sec.)

8. In Problem 5, find the throat and outlet diameters of a nozzle to discharge 1000 lb. of steam per hour, and sketch the nozzle.

(*Ans.*, throat diameter = 0.416 in.)

9. Check the value $\frac{P}{p} = 0.5274$ for maximum flow in Art. 522.

10. Check the equation of flow of a permanent gas, in Art. 522.
11. If the efficiency in Problem 5, from steam to shaft, is 0.60, find the steam consumption per brake hp.-hr., and the thermal efficiency.
12. In Problem 5, let the peripheral speed be $u=480$, the angle $\alpha=20^\circ$, and find the work done per pound of steam in a single-stage impulse turbine (a) with end thrust eliminated, (b) with equal relative angles. Allow a 10 per cent reduction of relative velocity for bucket friction.
13. In Problem 12, Case (b), what is the efficiency from steam to work at the buckets? (Item E, Art. 526.) Find the ideal steam consumption per Ihp.-hr.
14. Sketch the bucket in Problem 12, Case (b), as in Art. 530.
15. Compute the wheel diameters and design the first-stage nozzles and buckets for a two-stage impulse turbine, with two moving wheels in each stage, as in Art. 532, operating under the conditions of Problem 5, the capacity to be 1500 kw., the entering stream angles 20° , the peripheral speed 600 ft. per second, the speed 1500 r. p. m., the heat drop reduced 0.10 by nozzle friction. Arrange the bucket angles to give the highest practicable efficiency,* the stream velocities to be reduced 10 per cent by bucket friction. State the heat unit consumption per kw.-minute.
16. In Problem 5, plot by stages of about 10 B. t. u. the NT expansion path in a pressure turbine in which the heat drop is decreased 0.25 by bucket friction.
17. In Problem 16, the drums have peripheral speeds of 150, 250, 350. Construct a reasonable curve of steam velocities, as in Fig. 259, the velocity of the steam entering the first stage being 400 ft. per second, and the outputs of the three drums as $\frac{1}{6}$, $\frac{1}{3}$, $\frac{1}{2}$.
18. In Problem 17, let the absolute entrance angles be 20° , and let the velocity diagram be as in Fig. 260. Find the work done in each of six stages along each drum. Find the average heat drop per stage, and the number of stages in each drum, the total heat drop per drum having been obtained from Problem 16.
19. The speed of the turbine in Problem 18 is 400 r. p. m. Find the diameter of each drum.
20. In Problems 16–19, the blades are spaced 2" centers. The turbine develops 1500 kw. Find the heights of the moving blades for one expansive state, assuming losses between buckets and generator of 45 per cent. Design the moving bucket.
21. Sketch the arrangement of a turbine in which the steam first strikes a Pelton impulse wheel and then divides; one portion traveling through a three-drum *pressure* rotor axially, the other through a two-pressure stage *velocity* rotor with three rows of moving buckets in each pressure stage, also axially, the shaft of the velocity turbine being vertical.
22. Compare as to effect on thermal efficiency the methods of governing the De Laval, Curtis, and Westinghouse-Parsons turbines.
23. Determine whether the result given in Art. 541, reported for the S.S. *Turbinia*, is credible.

* The angle f must not be less than 24° in any case.

CHAPTER XV

RESULTS OF TRIALS OF STEAM ENGINES AND STEAM TURBINES

543. Sources. The most reliable original sources of information as to contemporaneous steam economy are the Transactions or Proceedings of the various national mechanical engineering societies (1). The reports of the Committee of the Institution of Mechanical Engineers on Marine Engine Trials are of special interest (2). The Alsatian experiments on superheating have already been referred to (Art. 443). The works of Barrus (3) and of Thomas (4) present a mass of results obtained on reciprocating engines and turbines respectively. The investigations of Isherwood are still studied (5). The *Code* of the American Society of Mechanical Engineers (*Trans. A. S. M. E.*, XXIV) should be examined.

543a. Steam Engine Evolution. The Cornish simple pumping engines (9) which developed from those of the original Watt type had by 1840 shown dry steam rates between $16\frac{1}{2}$ and 24 lb. per Ihp.-hr. They ran condensing, with about 30 lb. initial pressure, and ratios of expansion between $3\frac{1}{2}$ and $1\frac{1}{2}$, and were unjacketed. Excessive wiredrawing and the single-acting balanced exhaust (which produced almost the temperature conditions of a compound engine) led to a virtual absence of cylinder condensation.

The advantage of a large ratio of expansion was understood, and was supposed to be without definite limit until Isherwood (1860) demonstrated that expansion might be too long continued, and that increased condensation might arise from excessive ratios. Early compound engines, without any increase in expansion over the ratios common in simple engines, failed to produce any improvement, steam rates attained being around 19 lb. As higher boiler pressures (150 lb.) became possible, the ratio of expansion of 14, then adopted for compounds, promptly reduced steam rates to 15 lb. These have been gradually brought down to 12 lb. in good practice. The 5400 hp. Westinghouse compound of the New York Edison Co., with a 5.8 : 1 cylinder ratio, 185 lb. steam pressure and 29 expansions, reached the rate of 11.93 lb.

Triple engines, using still higher ratios of expansion, soon attained steam rates around $12\frac{1}{2}$ lb. The best record for a triple with saturated steam seems to be 11.05 lb., reached by the Hackensack, N. J., pumping engine, with 188 lb. throttle pressure and 33 expansions.

Quadruple engines, and engines with superheat, have shown still better results: see Arts. 549c, 549d, 550.

544. Limits and Measures of Efficiency. Art. 496 gives expressions for the Clausius (E_c) and relative (E_R) efficiencies corresponding with

given steam rates and pressure and temperature conditions. The efficiency of the turbine cannot exceed E_T . That of the reciprocating engine has for a still lower limit the Rankine efficiency, which is with saturated steam,

$$E_k^* = \frac{\frac{144}{778}(p_1 x_1 v_1 - p_3 x_2 v_2) + h_1 + x_1 r_1 - h_2 - x_2 r_2}{h_1 + x_1 L_1 - h_3},$$

where p_1 = upper pressure, lb. per sq. in., absolute;

p_2 = terminal pressure, lb. per sq. in., absolute (end of expansion);

p_3 = lower pressure, lb. per sq. in., absolute (atmosphere or condenser);

x_1 = initial dryness (beginning of expansion);

x_2 = terminal dryness (end of expansion);

v_1 = specific volume at pressure p_1 ;

v_2 = specific volume at pressure p_2 ;

h_1 = heat of liquid at pressure p_1 ;

h_2 = heat of liquid at pressure p_2 ;

h_3 = heat of liquid at pressure p_3 ;

r_1 = internal heat of vaporization at pressure p_1 ;

r_2 = internal heat of vaporization at pressure p_2 ;

L_1 = latent heat of vaporization at pressure p_1 .

With the regenerative cycle (Art. 550) the Carnot efficiency is the limit. With superheated steam, the Rankine cycle efficiency is

$$E_k = \frac{H - H_2 + \frac{144}{778} v_2 (p_2 - p_3)}{H - h_3},$$

where H = total heat in the superheated steam, B. t. u.;

H_2 = total heat above 32° at the end of adiabatic expansion;

v_2 = specific volume of the actual steam at the end of adiabatic expansion;

p_2 = pressure of steam at the end of adiabatic expansion, lb. per sq. in.;

p_3 = lowest pressure, lb. per sq. in.;

h_3 = heat of liquid at the pressure p_3 .

The efficiency ratio E_R is almost always between 0.4 and 0.8; in important practice, between 0.5 and 0.7. Attention is called

* The back pressure p_3 of best efficiency is not necessarily the lowest attainable.

to the table, Art. 551. Average values of the efficiency ratio seem to be:

	Condensing.	Non-condensing.
Simple	0.4	0.6
Compound	0.5	0.65
Triple	0.6	0.8 (Art. 549a).

With saturated steam, it is from 0.15 to 0.2 higher in non-condensing than in condensing engines, and increases by 0.05 to 0.1 as the number of expansive stages increases from 1 to 2 or from 2 to 3. With high superheat, E_R seems to be between 0.6 and 0.7 for both condensing and non-condensing engines having either one or two expansive stages. The figures given for saturated steam are increased 0.03 to 0.05 by jacketing. The steam rate (lb. dry steam per hp.-hr.) is scarcely a precise measure of performance, and is of very little significance when superheat is used. Results should preferably be expressed in terms of the thermal efficiency or B. t. u. consumed per Ihp.-min. (See Art. 551.)

545. Variables Affecting Performance. Some of these can be weighed from thermodynamic considerations alone: but in all cases it is well to confirm computed anticipations from tests. The essentially thermodynamic factors are:

- (a) Initial pressure (Art. 549 e);
- (b) Dryness or superheat (Arts. 549 f, 549 g);
- (c) Back pressure (Art. 549 h);
- (d) Ratio of expansion (Art. 549 i).

The factors influencing relative efficiency, to be considered primarily from experimental evidence, are

- (e) Wire-drawing (Art. 549 j);
- (f) Cylinder condensation including:
 - (1) Jacketing (Art. 549 m);
 - (2) Superheating (Art. 549 g);
 - (3) Multiple expansion and reheating (Arts. 549 m, 549 n);
 - (4) Speed, Size (Art. 549 o);
- (j) valve action (Arts. 546-548 b, 549 o, 551);
- (5) Ratio of expansion (Art. 549 i);

SUMMARY OF TESTS

546. Saturated Steam: Simple Non-condensing Engines, without Jackets.

Type of Valve.	Initial Gage Pressure, Lb.	R. p. m.	Size, Hp.	Ratio of Expansion.	Steam Rate, Lb.		Approximate Clausius Efficiency, E_f .	Relative Efficiency E_R
					Avg.	Limits		
Single, automatic, high compression	70-100	100-300	20-100	3-4	32½	30-38	0.141	0.55
Double, automatic	75-80	50-150	4	30	0.134	0.63
Four-valve, non-releasing	100	below 225	above 50	3-4½	29	26-32	0.15	0.58
Four-valve, releasing	100	below 100	above 75	3-4½	26	24-28	0.15	0.65

547. Saturated Steam, Simple Condensing Engines, without Jackets: Improved Valve Gear.

Valves.	Initial Gage Pressure, Lb.	R. p. m.	Size, Hp.	Ratio of Expansion.	Steam Rate, Lb.		(Approximate)	
					Average.	Range.	E_I	E_R
Non-releasing.	90-110	below 225	over 60	$3\frac{1}{2}$ -5	24	22-26	0.268	0.35
Releasing.....	90-100	below 100	over 100	$3\frac{1}{2}$ -5	$21\frac{1}{2}$	$19\frac{1}{2}$ - $23\frac{1}{2}$	0.266	0.40

548a. Saturated Steam, Compound Non-condensing Engines, without Jackets.

Valve.	Initial Gage Pressure, Lb.	R. p. m.	Size, Hp.	Steam Rate, Lb.	(Approximate)	
					E_I	E_R
Single, automatic.....	110-165	250-300	50-250	23.6	0.167	0.63
Double, automatic.....	120	265	165	23.2	0.162	0.67
Four-valve, releasing....	130	100	350-450	21.9	0.166	0.70
Willans.....	20.9	0.166	0.72

548b. Saturated Steam, Compound Condensing, without Jackets, Normal Cylinder Ratio.

Valve.	Initial Gage Pressure, Lb.	R. p. m.	Size, Hp	Steam Rate, Lb.	(Approximate)	
					E_I	E_R
Single, automatic.....	110-130	200-300	100-500	19.1	0.275	0.43
Double, automatic.....	120	160-170	100-300	16.3	0.275	0.50
Four-valve, releasing....	100-150	under 100	above 100	14.6	0.278	0.56

549a. Saturated Steam, Triple Expansion, without Jackets (12), (13), (14), (15).

Back Pressure.	Initial Gage Pressure, Lb.	Steam Rate, Lb.		(Approximate)	
		Average.	Range.	E_I	E_R
Non-condensing (8).....	$18\frac{1}{2}$		0.169	0.80
Condensing.....	124-200	$12\frac{1}{2}$	$11\frac{3}{4}$ -15	0.295	0.61

549*b*. Jacketed Engines, High Grade, Saturated Steam, Compounds Usually with Reheaters.

Type.	Steam Rate, Lb.	
	Jacketed.	Same Type of Engine, Unjacketed.
Small, non-condensing simple, 5 exp., 75 lb. gage pressure.	25	26-32½
Simple condensing, 120-150 lb. pressure.	17-20	19½-26
Woolf compound, condensing, 16 exp., 12 r. p. m., 120 lb. pressure.	13.6
Compound non-condensing.	19	20.9-23.6
Compound condensing, ordinary cylinder ratio *.. (Saving due to jackets, -1½ to +10.9 per cent: per cent of total steam consumed in jackets, about 5.0.)	13.5	14.6-19.1
Compound condensing, high cylinder ratio, 150-175-lb. pressure, about 30 expansions, 8 to 14 per cent of total steam used in jackets and reheaters.	11.9	
Triple condensing, 85 to 175 lb. pressure, 25 to 33 expansions.	11.05-11.75	11.75-15

* One engine gave, with jackets, 13.85; without jackets, 14.99.

549*c*. Superheated Steam, Reciprocating Engines.

Type.	Steam Rate, Lb.	B. t. u. per Hp.-min.	Approximate Clausius Efficiency.	Relative Efficiency.
Simple non-condensing, no jackets, slight superheat.	23			
Simple non-condensing, no jackets, 620° F. . .	15.3	319	0.182	0.66
Simple condensing, 800 hp., 4 exp., 65 lb. pressure, 450° F.	16	317	0.259	0.52
Simple condensing, 620° F.	11.6	234	0.27	0.67
Compound non-condensing, locomotive.	17.6
Compound condensing, 500° F.	12.9	253	0.291	0.57
Compound condensing, 620° F.	10.6	224	0.3	0.63
Compound condensing, 45 hp., 600-lb. pressure, 800° F. (19).	10.8	246	0.375	0.46
Triple condensing, 500°.	10.9	221	0.299	0.64
Triple condensing, 620°.	9.6	200	0.309	0.69

549*d*. Comparative Tests, Saturated and Superheated Steam.

Type.	Steam Rate, Lb.		B. t. u. per Hp.-min.	
	Saturated.	Superheated.	Saturated.	Superheated.
Compound condensing, 150-lb. pressure, superheated 250°	213-246	199-223
Compound condensing, 140-lb. pressure, superheated 400° (18)	13.84	9.56	247	205
Compound condensing, 130-lb. pressure, superheated 307°	11.98	8.99	225	192
(126 r. p. m., 250 hp., 32 exp.)(11)				

549*e*. Initial Pressure. Increased pressures have been so associated with development in other respects that it is difficult to show by experimental evidence just what gain in economy has been due to increased pressure alone. Art. 546 gives usual steam rates from 24-28 lb. for simple non-condensing engines of the best type, in this country, with initial pressures around 100 lb. In Germany, where pressures range from 150 to 180 lb., the corresponding rates are between 19 and 23 lb. per Ihp.-hr.

549*f*. Initial Dryness. The efficiency of the Clausius or Rankine cycle is greater as the initial dryness approaches 1.0 (Art. 417). No considerable amount of moisture is ever brought to the engine in practice, and tests fail to show any influence on dry steam consumption resulting from variations in the small proportion of entrained water.

549*g*. Superheat. There is no thermodynamic gain when superheating is less than 100°, because the steam is then brought to the dry condition by the time cut-off is reached. Tables 549*c* and 549*d* show that heat rates for compound engines with low superheat are around 250 B. t. u., and for triples about 220 B. t. u., while with high superheat the compound or the triple may reach about 200 B. t. u. With high superheat, exceeding 200° F., some gain due to temperature is realized in addition to the elimination of cylinder condensation. To properly weigh the effect of high superheat, all steam rates given for saturated steam should be reduced to the heat unit equivalent. This is done in the table shown at the top of page 403.

Adequate superheating thus causes a large gain in simple engines, either condensing or non-condensing. In either case, the simple engine using superheated steam is as economical as the ordinary compound engine using saturated steam, so that superheat may be regarded as a substitute for compounding. The best compounds and triples with superheat are (though in a less degree) superior to the same types of engine using saturated steam.

Type.	Steam Rate, Lb.	Initial Absolute Pressure, Lb.	Feed Temperature.	B. t. u. per Ihp.-min.	B. t. u. per Ihp.-min., Superheated.	Per Cent Gain by Superheating.
Simple non-condensing, best.	26	100	200°	434	319	26
Simple condensing, best.	21½	110	150°	383	234	39
Compound non-condensing.	22½	120	200°	380	332 (locomotive)	13
Compound condensing, ordinary.	15	150	150°	268	224-253	5-17
Compound condensing, high cylinder ratio (see Art. 549b).	12-13	175	150°	213-247	192-223	0-22
Triple condensing, average.	12½	175	150°	224	205-221	1-9

549h. Back Pressure. This is best investigated by considering the difference in performance of condensing and non-condensing engines. Arts. 546-549 c give:

Type.	Steam Rate, Lbs. per Ihp.-hr.		Per Cent Saving Due to Condensing.	
	Non-condensing.	Condensing.		
Saturated Steam, not jacketed {	Simple non-releasing.	29	24	17
	Simple, releasing.	26	21.5	17
	Compound (average)	22.2	16.7	17
	Triple.	18.5	12.5	32
Saturated steam, jacketed. {	Simple.	25	18.5 (average)	26
	Compound (usual type).	19	13.5	29
Superheated steam. {	Simple, average.	19.15	13.8	28
	Compound, average.	17.6	11.4	35

The arithmetical averages give about the results to be expected:

- (1) Condensing saves 24 per cent in simple engines, 27 per cent in compounds, 32 per cent in triples;
- (2) Condensing is relatively more profitable when jackets or superheat are used.

549i. Ratio of Expansion. This has been discussed in Art. 436. Since engines are usually governed (i. e., adapted to the external load) by varying the ratio of expansion, a study of the variation in efficiency with output is virtually a study of the effect of a changing ratio of expansion. (The question of mechanical efficiency (Arts. 554-558) somewhat complicates the matter.) Figure 236 gives the results

of such an investigation. The shape of the economy curve is of great importance. A flat curve means fairly good economy over a wide range of probable loads. The

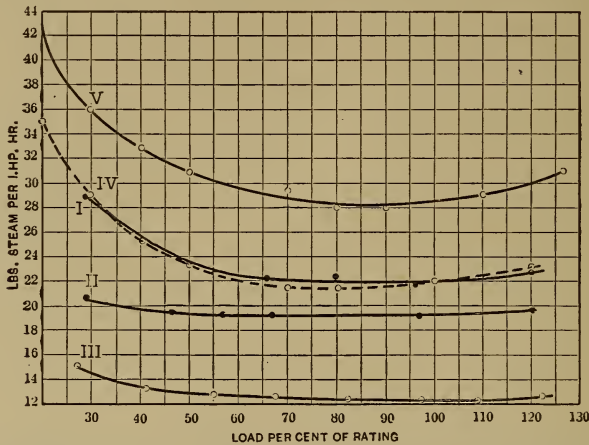

FIG. 266a. Art. 549i.—Efficiency at Various Ratios of Expansion.

flatness varies with different types of engine. A few typical curves are given in Fig. 266a. Curve I is from a single-acting Westinghouse compound engine, running non-condensing. Curve II is from the same engine, condensing (*Trans. A. S. M. E.*, XIII, 537). Curve III is for the 5400-hp. Westinghouse compound condensing engine mentioned in Art. 543a. Curve IV is for a small four-valve simple non-condensing engine: curve V for a single-valve high-speed simple non-condensing engine.

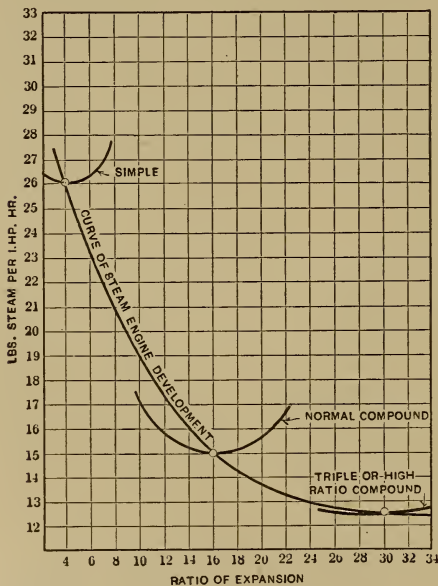

FIG. 266b. Art. 549i.—Efficiency and Ratio of Expansion.

If we regard the usual ratio of expansion in a compound as 16, in a simple engine, 4, and in a triple or high-ratio compound as 30, with corresponding steam rates of 15, 26, and $12\frac{1}{2}$ (condensing engines), we obtain the curves of Fig. 266 b, showing a steady gain of efficiency as the total ratio of expansion increases, providing two stages of expansion are used when the ratio exceeds some value between 4 and 16. It appears that no considerable further gain can be expected by increasing either the ratio of expansion or the number of stages.

549j. Wire-drawing. None of the tests above quoted applies to throttling engines. Cut-off regulation is now almost universal. Moderate throttling may be desirable at high ratios of expansion (Art. 426). A large part of the 8 per cent difference in steam consumption between the single-valve and double-valve engines of Art. 546 (15 per cent in Art. 548 *b*) is due to the partial throttling action of the single valve at cut-off. The difference between the performances of four-valve engines with and without releasing gear is very largely due to the comparative absence of wire-drawing in the former. This difference is 10 per cent in Art. 546.

549k. Leakage. The average steam rate ascertained on engines which had run from 1 to 5 years without refitting of valves or pistons (7) was 39.3 lb. This was for simple single-valve non-condensing machines, for which the figure given in Art. 546 is $32\frac{1}{2}$. Some of the difference was due to the fact that the engines tested ran at light loads ($\frac{3}{8}$ to $\frac{2}{3}$ normal: see Art. 549 *i* and Fig. 266) but a part must also have been due to leakage resulting from wear. In 65 tests reported by Barrus, the average steam rate of engines known to have leaking valves or pistons was 4.8 per cent higher than that of those which were known to be tight. Leakage is less in compound than in simple engines. (See Art. 452.)

549l. Compression, Clearance. The theory of compression has been discussed (Art. 451). High-speed engines have more compression than those running at low speed. The compression in compound engines is less than that in simple engines. There is an amount of compression (usually small) at which for a given engine and given conditions the efficiency will be a maximum. No general results can be given. The maximum desirable compression occurs at a moderate cut-off: at other points of cut-off, compression should be less. Within any range that could reasonably be prescribed, the amount of compression does not seriously influence efficiency.

Clearance is a necessary evil, and the waste which it causes is only partially offset by compression. Designers aim to make the amount of clearance (which depends upon the type and location of the valves) as small as possible. The proportion of clearance in steam engines of various types is given in Art. 450. The differences between the steam rates of single valve and Corliss valve engines, shown in Arts. 546 to 548 *b*, already mentioned as partly due to wire-drawing, are also in part attributable to differences in clearance.

549m. Jackets. The saving due to jackets may range from nothing (or a slight loss) up to 20 per cent or more. Art. 549 *b* shows minimum savings of 6 to 9 per cent and maximum of 19 to 23 per cent, for one, two or three expansive stages. Yet there are undoubtedly cases where jackets have not paid, and they are not usually applied (excepting on pumping engines) in American stationary practice to-day. The best records made by compounds and triples have been in jacketed engines. This is with saturated steam. With superheat, jackets are not warranted. The proportion of steam used in jackets (of course charged to the engine) ranges usually between 0.03 and 0.08, increasing with the number of expansive stages. Jacketing pays best at slow speeds and high ratios of expansion.

Reheaters for compound engines can scarcely be discussed separately from jackets. It is difficult to get an adequate amount of transmitting surface without making the receiver very large. The objection to the reheater is the same as that to the jacket—increased attention is necessary in operation and maintenance. There is an irreversible drop of temperature inherent in the operation of the reheater.

549*n*. Multiple Expansion. The tables already given furnish the following:

No. of expansion stages . . . Type.	UNJACKETED ENGINES					
	Steam Rate, Lb. per Ihp.-hr.			Non-condensing.		
	Condensing.			1	2	3
1	2	3	1	2	3	
Single-valve	19.1	32½	23.6	..	
Double-valve	16.3	30	23.2	..	
Four-valve, non-releasing.	24	29	
Four-valve, releasing . . .	21½	14.6	12.5	26	21.9	18.5
Superheat, good valve . . .	11.6-16	10.6-12.9	9.6-10.9	15.3-23	17.6	..

The non-condensing engine with a cheap type of valve is 23 to 27 per cent more economical in the compound form than when simple. (The non-condensing compound is on other grounds than economy an unsatisfactory type of engine, see *American Machinist*, Nov. 19, 1891.) In four-valve releasing engines, non-condensing, the compound saves 16 per cent over the simple and the triple saves 16 per cent over the compound. The same engines, condensing, give a saving of 32 per cent by compounding and an additional saving of 14 per cent by triple expansion. With superheat, non-condensing, the compound is from 15 per cent worse to 23 per cent better than the simple engine. Condensing, the compound saves 15 per cent over the simple and the triple saves 13 per cent over the compound.

High Ratio Compounds have been discussed in Art. 473. The tests in Art. 548 *b* include only compound engines of normal cylinder ratio. The following results have been attained with wider ratios:

	Lbs. per Ihp.hr.
150-lb. pressure, 26 exp., ratio 7 : 1	12.45 (jacketed)
150-lb. pressure, 120 r. p. m., 33 exp.	12.1 (head jacketed)
130-lb. pressure, 126 r. p. m., 32 exp.	11.98 (jacketed)

These figures are practically equal to those reached by triple engines. They are due to (a) high ratios of expansion, (b) jacketing, and (c) the high cylinder ratio.

549*o*. Speed and Size: Efficiency in Practice. None of the tests shows a steam rate below 16.3 lb. at speeds above 140 r. p. m. Low rotary speed is essential to the highest thermal efficiency. Between very wide limits—say 100 or 200 to 2500 hp.—the size of an engine only slightly influences its steam rate. Very small units are wasteful (some direct-acting steam pumps have been shown to use as much as 300 lb. of steam per Ihp.-hr)(6) and very large engines are usually built with such refinement of design as to yield maximum efficiencies.

All figures given are from published tests. It is generally the case that *poor* performances are not published. The tabulated steam rates will not be reached in ordinary operation: first, because the load cannot be kept at the point of maximum efficiency (Art. 549 *i*)—nor can it be kept steady—and second, because under other than test conditions engines will leak. Probably few bidders would guarantee results, even at steady load, within 10 per cent of those quoted. In estimating the probable steam rate of an engine in operation, this 10 per cent should first be added, correction should then be made for actual load conditions, based on such a curve as that of Fig. 266, and an additional allowance of 5 per cent or upward should then be made for leakage.

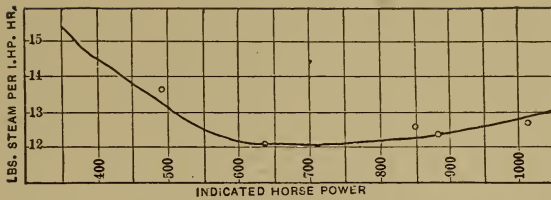

FIG. 266. Arts. 549i, 556.—Test of Rice and Sargent Engine (10).

550. Quadruple Engines: Regenerative Cycle. Some of the best performances on record with saturated steam have been made in quadruple-expansion engines. The Nordberg pumping engine at Wildwood (16), although of only 6,000,000 gal. capacity (712 horse power) and jacketed on barrels of cylinders only, gave a heat consumption of 186 B. t. u. with 200 lb. initial pressure and only a fair vacuum. The high efficiency was obtained by drawing off live steam from each of the receivers and transferring its high-temperature heat direct of the boiler feed water by means of coil heaters. Heat was thus absorbed more nearly at the high temperature limit, and a closer approach made to the Carnot cycle than in the ordinary engine. Thus, in Fig. 267, *BCDS* represents the Clausius cycle. The heat areas *hIHE*, *gKJh*, *NMLg* represent the withdrawal of steam from the various receivers, these amounts of heat being applied to heating the water along *Bd*, *de*, *ef*. The heat imparted from without is then only *cfCDE*. The work area *DHIJKLMRS* has been lost, but the much greater heat area *ABfc* has been saved, so that the efficiency is increased. The cycle is regenerative; if the number of steps were infinite, the expansive path would be *DF*, parallel to *BC*, and the cycle would be equally efficient with that of Carnot. The actual efficiency was 68 per cent of that of the Carnot cycle. The steam rate was not low, being increased by the system of drawing off steam for the heaters from 11.4 to 12.26; but the real efficiency was, at the time, unsurpassed. A later test of a Nordberg engine of similar construction, used to drive an air compressor, is reported by Hood (17). Here the combined diagrams were as in Fig. 268. Steam was received at 257 lb. pressure, the vacuum being rather poor.

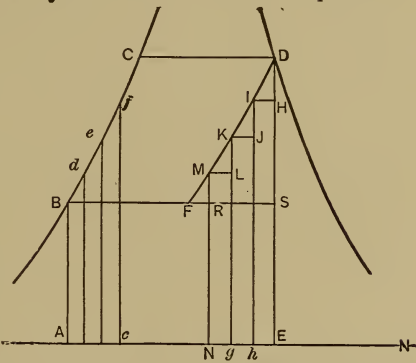

FIG. 267. Art. 550.—Nordberg Engine Diagrams.

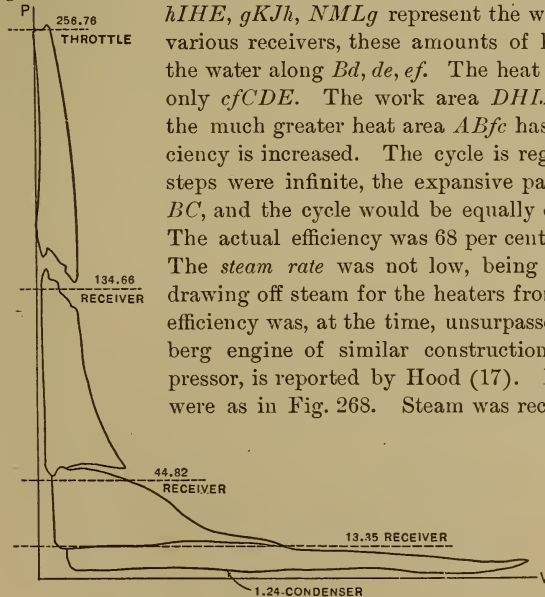

FIG. 268. Art. 550.—Hood Compressor Diagrams.

At normal capacity, 1000 hp., the mechanical efficiency was 90.35 per cent, and the heat consumption 169.29 B. t. u.

551. Summary of Best Results, Reciprocating Stationary Engines.

	Lbs. Steam per Ihp.-hr.	Efficiency Ratio (Art. 496)	B. t. u. per Ihp.-min.
Saturated steam, simple, non-condensing, single valve, without jackets	32½	0.55	548
Saturated steam, simple, non-condensing, double valve, without jackets	30	0.63	502
Saturated steam, simple, non-condensing, four valve, releasing, without jackets . . .	26	0.65	434
Saturated steam, simple, non-condensing, with jackets	25	0.68	418
Saturated steam, compound non-condensing, without jackets	22	0.63-0.72	353
Saturated steam, simple condensing, four valve releasing, without jackets	21½	0.40	333
Saturated steam, compound non-condensing, with jackets, four valve	19	0.71-0.82	305
Saturated steam, compound condens- ing, normal ratio, single valve, no jackets	19	0.43	359
Saturated steam, simple condensing, with jackets	18½	0.45	330
Superheated, compound non-condensing (locomotive)	17½	0.58	332
Superheated (620° F.) steam, simple, non- condensing	15	0.66	319
Saturated steam, compound condensing, four valve, no jackets	14½	0.56	274
Saturated steam, compound condensing, normal ratio, four valve, with jackets . .	13½	0.60	255
Saturated steam, triple condensing, no jackets	12½	0.61	234
Saturated steam, high ratio compound con- densing, jacketed	12	0.63	226
Superheated (620° F.) steam, simple, con- densing	11½	0.67	234
Saturated steam, triple condensing, with jackets	11½	0.66	205
Superheated (620° F.) steam, compound con- densing	10½	0.63	224
Superheated (620° F.) steam, triple con- densing	9½	0.69	200
Saturated steam, quadruple, condensing		*	169

* Efficiency is 77 per cent. that of the *Carnot* cycle between the same extreme temperature limits.

552. Turbines. With pressures of from 78.8 to 140 lb.,* and vacuum from 24.3 to 26.4 in., steam rates per **brake** horse power of 18.0 to 23.2 have been obtained with saturated steam on De Laval turbines. Dean and Main (20) found corresponding rates of 15.17 to 16.54 with **saturated** steam at 200 lb. pressure, and 13.94 to 15.62 with this steam superheated 91°.

Parsons turbines, with saturated steam, have given rates per **brake** horse power from 14.1 to 18.2; with superheated steam, from 12.6 to 14.9. This was at 120 lb. pressure. A 7500-kw. unit tested by Sparrow (21) with 177.5 lb. initial pressure, 95.74° of superheat, and 27 in. of vacuum, gave 15.15 lb. of steam per kw.-hr. Bell reports for the *Lusitania* (22) a coal consumption of 1.43 lb. per horse power hour delivered at the shaft. Denton quotes (23) 10.28 lb. per **brake** horse power on a 4000 hp. unit, with 190° of superheat (214 B. t. u. per minute); and 13.08 on a 1500-hp. unit using saturated steam. A 400-kw. unit gave 11.2 lb. with 180° of superheat. A 1250-kw. turbine gave 13.5 lb. with saturated steam, 12.8 with 100° of superheat, 13.25 with 77° of superheat (24). (All per *brake* hp.-hr.)

A Rateau machine, with slight superheat, gave rates from 15.2 to 19.0 lb. per **brake** horse power. Curtis turbines have shown 14.8 to 18.5 lb. per kw.-hr., as the superheat decreased from 230° to zero, and of 17.8 to 22.3 lb. as the back pressure increased from 0.8 to 2.8 lb. absolute. Kruesi has claimed (25) for a 5000-kw. Curtis unit, with 125° of superheat, a steam-rate of 14 lb. per kw.-hr.; and for a 2000-kw. unit, under similar conditions, 16.4 lb.

A 2600-kw. Brown-Boveri turbo-alternator at Frankfort consumed 11.1 lb. of steam per electrical horse-power-hour with steam at 173 lb. gauge pressure, superheated 196° and at 27.75 ins. vacuum. The 7500-kw. Allis cross-compound engines of the Interborough Rapid Transit Co., New York, with 190 lb. gauge pressure and 25 ins. vacuum (saturated steam) used 17.82 lb. steam per kw.-hr. When exhaust turbines were attached (Art. 541) the steam rate for the whole engine became between 13 and 14 lb. per kw.-hr., or (at 28 ins. vacuum) the B. t. u. consumed per kw.-min., ranged from 245 to 264; say, approximately from 156 to 168 B. t. u. per 1hp.-min., which was better than any result ever reached by a reciprocating engine or a turbine alone. Heat unit consumptions below 280 B. t. u. per kw.-min. (190 per 1hp.-min.) have been obtained in many turbine tests.

553. Locomotive Tests. The surprisingly low steam rate of 16.60 lb. has been obtained at 200 lb. pressure, with superheat up to 192°. This is equivalent to a rate of 17.8 lb. with saturated steam. The tests at the Louisiana Purchase Exposition (26) showed an average steam rate of 20.23 lb. for all classes of engines tested, or of 21.97 for simple engines and 18.55 for compounds, with steam pressures ranging from 200 to 225 lb. These results compare most favorably with any obtained from high-speed non-condensing stationary engines. The mechanical efficiency of the locomotive, in spite of its large number of journals, is high; in the tests referred to, under good conditions, it averaged 88.3 per cent for consolidation engines and 89.1 per cent for the Atlantic type. The reason for these high efficiencies arises from the heavy overload carried in the cylinder in ordinary service. The maximum equivalent evaporation per square foot of heating surface varied from 8.55 to 16.34 lb. at full load, against a usual rate not exceeding 4.0 lb. in stationary boilers; the boiler efficiency consequently was low, the equivalent evaporation per pound of dry coal (14,000 B. t. u.) falling from 11.73 as a maximum to 6.73 as a minimum, between the extreme ranges of load. Notwithstand-

* Pressures in this chapter, unless otherwise stated, are *gauge* pressures

ing this, a coal consumption of 2.27 lb. per Ihp.-hr. has been reached. These trials were, of course, laboratory tests; road tests, reported by Hitchcock (27), show less favorable results; but the locomotive is nevertheless a highly economical engine, considering the conditions under which it runs.

554. Engine Friction. Excepting in the case of turbines, the figures given refer usually to indicated horse power, or horse power developed by the steam in the cylinder. The **effective horse power**, exerted by the shaft, or **brake horse power**, is always less than this, by an amount depending upon the friction of the engine. The ratio of the latter to the former gives the **mechanical efficiency**, which may range from 0.85 to 0.90 in good practice with rotative engines of moderate size, and up to 0.965 in exceptional cases. (See Art. 497.) The brake horse power is usually determined by measuring the pull exerted on a friction brake applied to the belt wheel. When an engine drives a generator, the power indicated in the cylinder may be compared with that developed by the generator, and an over-all efficiency of mechanism thus obtained. The difficulties involved have led to the general custom, in turbine practice, of reporting steam rates per kw.-hr. Thurston has employed the method of driving the engine as a machine from some external motor, and measuring the power required by a transmission dynamometer.

In direct-driven pumps, air compressors and refrigerating machines, the combined mechanical efficiency is found by comparing the indicator diagrams of the steam and pump cylinders. These efficiencies are high, on account of the decrease in number of bearings, crank pins, and crosshead pins.

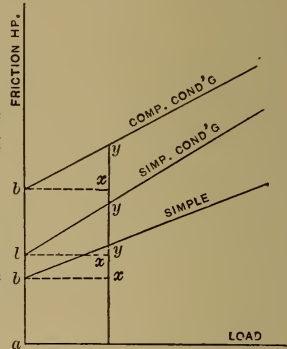

555. Variation in Friction. Theoretically, at FIG. 269. Art. 555.—Engine Friction.

least, the friction includes two parts: the **initial friction**, that of the stuffing boxes, which remains practically constant; and the **load friction**, of guides, pins, and bearings, which varies with the initial pressure

and expansive ratio. By plotting concurrent values of the brake horse power and friction horse power, we thus obtain such a diagram as that of Fig. 269, in which the height *ab* represents the constant initial friction, and the variable ordinate *xy* the load friction, increasing in arithmetical proportion with the load. It has been found, however, that in practice the total friction is more affected by accidental variations in lubrication, etc., than by changes in load, and that it may be regarded as practically constant, for a given engine, at all loads.

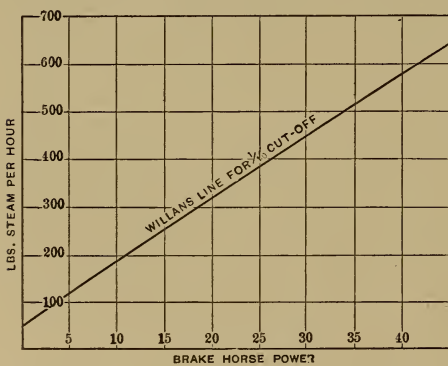

FIG. 270. Art. 555.—Willans Line for Varying Initial Pressure.

The total steam consumption of an engine at any load may then be regarded as made up of two parts: a constant amount, necessary to overcome friction; and a variable amount, necessary to do external work, and varying with the amount of that work.

Willans found that this latter part varied in exact arithmetical proportion with the load, when the output of the engine was varied by *changing the initial pressure*; a condition represented by the **Willans line** of Fig. 270 (28). The steam rate was thus the same for all loads, excepting as modified by friction. (Theoretically, this should not hold, since lowering of the initial pressure lowers the efficiency.) When the load is changed by *varying the ratio*

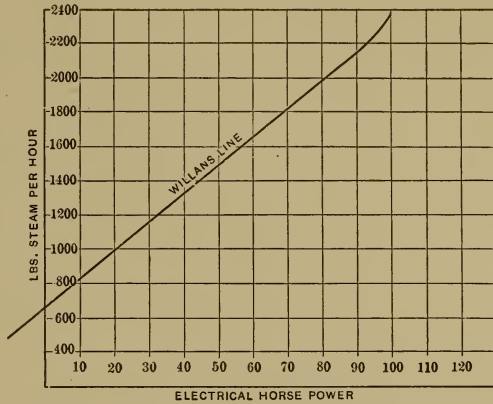

FIG. 271. Art. 556, Prob. 10.—Willans Line for a Parsons Turbine.

of expansion, the corrected steam rate tends to decrease with increasing ratios, and to increase on account of increased condensation; there is, however, some gain up to a certain limit, and the Willans line must, therefore, be concave upward. Figure 271 shows the practically straight line obtained from a series of tests of a Parsons turbine. If the line for an ordinary engine were perfectly straight, with varying ratios of expansion, the indication would be that the gain by more complete expansion was exactly offset by the increase in cylinder condensation. A jacketed engine, in which the influence of condensation is largely eliminated, should show a maximum curvature of the Willans line.

556. Variation in Mechanical Efficiency. With a constant friction loss, the mechanical efficiency must increase as the load increases, hence the desirability of running engines at full capacity. This is strikingly illustrated in the locomotive (Art. 554). Engines operating at serious variations in load, as in street railway power plants, may be quite wasteful on account of the low mean mechanical efficiency.

The curve in Fig. 266 gives data for the "Total" curve of Fig. 271*a*, which is plotted on the assumption that the horse power consumed in overcoming friction is 100, and the corresponding total weight of steam 1000 lb. per hour. Thus, at 700 lhp., the steam rate from Fig. 266 is 12.1 lb., and the steam consumed per hour is 8470 lb. The corresponding ordinate of the second curve in Fig. 271*a* is then

$$(8470 - 1000) \div (700 - 100) = 7470 \div 600 = 12.45,$$

where the abscissa is 600.

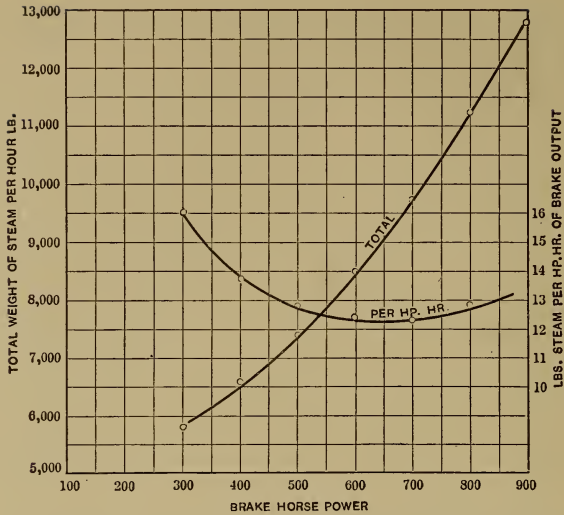

Fig. 271a. Art. 556.—Effect of Mechanical Efficiency.

557. Limit of Expansion. Aside from cylinder condensation, engine friction imposes a limit to the desirable range of expansion. Thus, in Fig. 272, the line

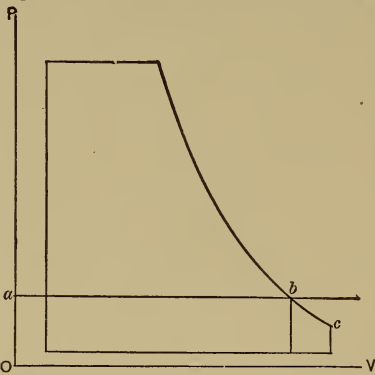

Fig. 272. Art. 557.—Engine Friction and Limit of Expansion.

ab may be drawn such that the constant pressure *Oa* represents that necessary to overcome the friction of the engine. If expansion is carried below *ab*, say to *c*, the force exerted by the steam along *bc* will be less than the resisting force of the engine, and will be without value. The maximum desirable expansion, irrespective of cylinder condensation, is reached at *b*.

558. Distribution of Friction. Experimenting in the manner described in Art. 555, Thurston ascertained the distribution of the friction load by successively removing various parts of the engine mechanism.

Extended tests of this nature, made by Carpenter and Preston (29) on a horizontal engine indicate that from 35 to 47 per cent of the whole friction load is imposed by the shaft bearings, from 22 to 49 per cent by the piston, piston rod, pins, and slides (the greater part of this arising from the piston and rod), and the remaining load by the valve mechanism.

OUTLINE OF CHAPTER XV

Sources of information : development of steam engine economy.
 Limit of efficiency (Rankine cycle); with the regenerative engine, the Carnot cycle;
 with the turbine, the Clausius cycle. Efficiency vs. steam rate.

Variables affecting performance :

- Efficiency varies directly with initial pressure ;
- is independent of initial dryness ;
- is increased by high superheat (superheat is a substitute for compounding) ;
- varies inversely as the back pressure, and is greater in condensing than in non-condensing engines ;
- reaches a maximum at a moderate ratio of expansion and decreases for ratios above or below this ;
- varies directly with the number and independence of valves ;
- may be seriously reduced by leakage or high compression ;
- is usually somewhat increased by jacketing ;
- increases with the number of expansive stages, though more and more slowly ;
- is low in very small engines or at very high rotative speeds ;
- in ordinary practice is below published records.

Typical figures for reciprocating engines and turbines, with saturated and superheated steam, simple vs. compound, condensing vs. non-condensing, with and without jackets, triple and quadruple regenerative.

- (1) *Trans. A. S. M. E., Proc. Inst. M. E., Zeits. Ver. Deutsch. Ing.*, etc. (See *The Engineering Digest*, November, 1908, p. 542.) (2) *Proc. Inst. Mech. Eng.*, from 1889. (3) *Engine Tests*, by Geo. H. Barrus. (4) *Steam Turbines*, 1906, 208-267. (5) *Researches in Experimental Steam Engineering*. (6) Peabody, *Thermodynamics*, 1907, 244 ; White, *Jour. Am. Soc. Nav. Engrs.*, X. (7) *Trans. A. S. M. E.*, XXX, 6, 811. (8) Ewing, *The Steam Engine*, 1906, 177. (9) Denton, *The Stevens Institute Indicator*, January, 1905. (10) *Trans. A. S. M. E.*, XXIV, 1274. (11) Denton, *op. cit.* (12) Ewing, *op. cit.*, 180. (13) *Trans. A. S. M. E.*, XXI, 1018. (14) *Ibid.*, XXI, 327. (15) *Ibid.*, XXI, 793. (16) *Ibid.*, XXI, 181. (17) *Ibid.*, XXVIII, 2, 221. (18) *Ibid.*, XXV, 264. (19) *Ibid.*, XXVIII, 2, 225. (20) Thomas, *Steam Turbines*, 1906, 212. (21) *Power*, November, 1907, p. 772. (22) *Proc. Inst. Nav. Archts.*, April 9, 1908. (23) *Op. cit.* (24) *Trans. A. S. M. E.*, XXV, 745 *et seq.* (25) *Power*, December, 1907. (26) *Locomotive Tests and Exhibits*, published by the Pennsylvania Railroad. (27) *Trans. A. S. M. E.*, XXVI, 054. (28) *Min. Proc. Inst. C. E.*, CXIV, 1893. (29) Peabody, *op. cit.*, p. 296.

PROBLEMS

(See footnote, Art. 552.)

1. Find the heat unit consumption of an engine using 30 lb. of dry steam per Ihp.-hr. at 100 lb. gauge pressure, discharging this steam at atmospheric pressure. How much of the heat (ignoring radiation losses) in each pound of steam is rejected ? What is the quality of the steam at release ?

(*Ans.*, *a*, 504.4 B. t. u. per minute ; *b*, 1088.8 B. t. u. ; *c*, 93.6 per cent.)

2. What is the mechanical efficiency of an engine developing 300 Ihp., if 30 hp. is employed in overcoming friction ? (*Ans.*, 90 per cent.)

3. Why is it unprofitable to run multiple expansion engines non-condensing ?

4. Find the heat unit consumptions corresponding to the figures in Art. 552 for De Laval turbines, assuming the vacuum to have been 27 in.*

(*Ans.*, *a*, 295; *b*, 286 B. t. u. per minute.)

5. Find the heat unit consumption for the 7500-kw. unit in Art. 552.

(*Ans.*, 296.3 B. t. u.)

6. Estimate the probable limit of boiler efficiency of the plant on the S.S. *Lusitania*, if the coal contained 14,200 B. t. u. per lb.

(*Ans.*, if engine thermal efficiency were 0.20, mechanical efficiency 0.90, the boiler efficiency must have been at least 0.69.)

7. Determine from data given in Art. 553 whether a coal consumption of 2.27 lb. per Ihp.-hr. is credible for a locomotive.

8. Using values given for the coal consumption and mechanical efficiency, with how little coal (14,000 B. t. u. per pound), might a locomotive travel 100 miles at a speed of 50 miles per hour, while exerting a pull at the drawbar of 22,000 lb.? Make comparisons with Problem 8, Chapter II, and determine the possible efficiency from coal to drawbar. (*Ans.*, *a*, 14,755 lb.; *b*, 7.2 per cent.)

9. An engine consumes 220 B. t. u. per Ihp.-min., 360 B. t. u. per kw.-min. of generator output. The generator efficiency is 0.93. What is the mechanical efficiency of the direct-connected unit? (*Ans.*, 88 per cent.)

10. From Fig. 271, plot a curve showing the variation in steam consumption per kw.-hr. as the load changes.

11. An engine works between 150 and 2 lb. absolute pressure, the mechanical efficiency being 0.75. What is the desirable ratio of (hyperbolic) expansion, friction losses alone being considered, and clearance being ignored? (*Ans.*, 12.25.)

12. If the mechanical efficiency of a rotative engine is 0.85, what should be its mechanical efficiency when directly driving an air compressor, based on the minimum values of Art. 558? (*Ans.*, 0.94.)

13. In the jacket of an engine there are condensed 310 lb. of steam per hour, the steam being initially 4 per cent wet. The jacket supply is at 150 lb. absolute pressure, and the jacket walls radiate to the atmosphere 52 B. t. u. per minute. How much heat, per hour, is supplied by the jackets to the steam in the cylinder?

14. A plant consumes 1.2 lb. of coal (14,000 B. t. u. per lb.) per brake hp.-hr. What is the thermal efficiency?

* Vacua are measured *downward* from atmospheric pressure. One atmosphere = 14.696 lb. per square inch = -29.921 inches of (mercury) vacuum. If p = absolute pressure, pounds per square inch, v = vacuum in inches of mercury,

$$v = 29.921 \left(1 - \frac{p}{14.696} \right).$$

$$p = \frac{14.696}{29.921} (29.921 - v).$$

CHAPTER XVI

THE STEAM POWER PLANT

560. Fuels. The complex details of steam plant management arise largely from differences in the physical and chemical constitution of fuels. "Hard" coal,* for example, is compact and hard, while soft coal is friable; the latter readily breaks up into small particles, while the former maintains its initial form unless subjected to great intensity of draft. Hard coal, therefore, requires more draft, and even then burns much less rapidly than soft coal; and its low rate of combustion leads to important modifications in boiler design and operation in cases where it is to be used. Soft coal contains large quantities of volatile hydrocarbons; these distill from the coal at low temperature, but will not remain ignited unless the temperature is kept high and an ample quantity of air is supplied. The smaller sizes of anthracite coal are now the cheapest of fuels, in proportion to their heating value, along the northern Atlantic seaboard; but the supply is limited and the cost increasing. In large city plants, where fixed charges are high, soft coal is often commercially cheaper on account of its higher normal rate of combustion, and the consequently reduced amount of boiler surface necessary. The sacrifice of fuel economy in order to secure commercial economy with low load factors is strikingly exemplified in the "double grate" boilers of the Philadelphia Rapid Transit Company and the Interborough Rapid Transit Company of New York (1).

561. Heat Value. The heat value or heat of combustion of a fuel is determined by completely burning it in a calorimeter, and noting the rise in temperature of the calorimeter water. The result stated is the number of heat units evolved per pound with products of combustion cooled down to 32° F. Fuel oil has a heat value upward of 18,000 B. t. u. per pound; its price is too high, in most sections of the country, for it to compete with coal. Wood is in some sections available at low cost; its heat value ranges from 6500 to 8500 B. t. u. The heat values of commercial coals range from 8800 to 15,000 B. t. u. Specially designed furnaces are usually necessary to burn wood economically.

* A coal may be called *hard*, or anthracite, when from 89 to 100 per cent of its combustible is *fixed* (non-volatile, uncombined) *carbon*. If this percentage is between 83 and 89, the coal is *semi-bituminous*; if less than 83, it is *bituminous*, or *soft*.

TABLE—COMBUSTION DATA FOR VARIOUS FUELS

	Symbol.	Equivalent Reaction.†	B. t. u. per Lb.
Hydrogen.....	H	$H_2 + O = H_2O$	62,100‡
Carbon.....	C	$C + O = CO$	4,450
Carbon.....	C	$C + O_2 = CO_2$	14,500
Carbon monoxide.....	CO	$CO + O = CO_2$	4,385
Acetylene.....	C_2H_2	$C_2H_2 + O_5 = 2CO_2 + H_2O$	21,400‡
Methane.....	CH_4	$CH_4 + O_4 = CO_2 + 2H_2O$	23,842‡
Ethylene.....	C_2H_4	$C_2H_4 + O_6 = 2CO_2 + 2H_2O$	21,250‡
Sulphur.....	S	$S + O_2 = SO_2$	4,100
Gasolene*.....	C_6H_{14}	$C_6H_{14} + O_{19} = 6CO_2 + 7H_2O$	19,000‡

* Gasolene is a variable mixture of hydrocarbons, C_6H_{14} being a probable approximate formula.

† The number of atoms in the molecule is disregarded.

‡ These figures represent the "high values." When hydrogen, or a fuel containing hydrogen, is burned, the maximum heat is evolved if the products of combustion are cooled below the temperature at which they condense, so that the latent heat of vaporization is emitted. The "low heat value" would be $(970.4 \times w)$ B. t. u. less than the high value when w is the weight in pounds of steam formed during the combustion, if the final temperatures of the products of combustion were the same in both "high" and "low" determinations. When the products of combustion are permanent gases there is no distinction of heat values.

561a. Computed Heat Values. When a fuel contains hydrogen and carbon only, its heat value may be computed from those of the constituents. If oxygen also is present, the heat of combustion is that of the substances uncombined with oxygen. Thus in the case of cellulose, $C_6H_{10}O_5$, the hydrogen is all combined with oxygen and unavailable as a fuel. The carbon constitutes the $\frac{72}{162} = 0.444$ part of the substance, by weight, and the computed heat value of a pound of cellulose is therefore $0.444 \times 14,500 = 6430$ B. t. u.

The heat of combustion of a compound may, however, differ from that of the combustibles which it contains, because a compound must be decomposed before it can be burned, and this decomposition may be either *exothermic* (heat emitting) or *endothermic* (heat absorbing). In the case of acetylene, C_2H_2 , for example, if the heat evolved in decomposition is 3200 B. t. u., the "high" heat of combustion is computed as follows:

$$\begin{aligned}
 C &= \frac{24}{6} \times 14,500 &= 13,400 \\
 H &= \frac{2}{6} \times 62,100 &= 4,790 \\
 \text{Heat of decomposition} &= 3,200 \\
 \text{Heat value} &= \underline{21,390}
 \end{aligned}$$

With an endothermic compound the heat of combustion will of course be *less* than that calculated from the combustibles present.

Suppose 0.4 cu. ft. of gas to be burned in a calorimeter, raising the temperature of 10 lb. of water 25° F. The heat absorbed by the water is $10 \times 25 = 250$ B. t. u., and the heat value of the gas is $250 \div 0.4 = 625$ B. t. u. per cu. ft. If the temperature of the gas at the beginning of the operation were 40° F., and its pressure 30.5 ins. of mercury, then from the relation

$$\frac{PV}{T} = \frac{pv}{t}, \quad \frac{30.5 V}{40 + 460} = \frac{29.92 v}{32 + 460}$$

$$v = 1.001V.$$

we find that a cubic foot of gas under the assigned conditions would become 1.001 cu. ft. of gas under standard conditions (32° F. and 29.92 in. barometer). The heat value per cubic foot under standard conditions would then be $625 \div 1.001 = 624.4$ B. t. u.

These are the "high" heat values. Suppose, during the combustion, $\frac{1}{2}$ lb. of water to be condensed from the gas, at 100° F. Taking the latent heat at 970.4 and the heat evolved in cooling from 212° to 100° at 112 B. t. u., the heat contributed during condensation and cooling would be $0.05(970.4 + 112) = 54.12$ B. t. u., and the "low" heat value of the gas under the actual conditions of the experiment would be $625 - 54.12 = 570.88$ B. t. u.

The tabulated "heat value" of a fuel is usually the amount of heat liberated by 1 lb. thereof when it and the air for combustion are supplied at 32° F. and atmospheric pressure, and when the products of combustion are completely cooled down to these standard conditions. In most applications, the constituents are supplied at a temperature above 32° F., and the products of combustion are not cooled down to 32° F. Two corrections are then necessary: an *addition*, to cover the heat absorbed in raising the supplied fuel and air from 32° to their actual temperatures, and a *deduction*, equivalent to the amount of heat which would be liberated by the products of combustion in cooling from their actual condition to 32°.

562. Boiler Room Engineering. While the limit of progress in steam engine economy has apparently been almost realized, large opportunities for improvement are offered in boiler operation. This is usually committed to cheap labor, with insufficient supervision. Proper boiler operation can often cheapen power to a greater extent than can the substitution of a good engine for a poor one. New designs and new test records are not necessary. Efficiencies already reported equal any that can be expected; but the attainment of these efficiencies in ordinary operation is essential to the continuance in use of steam as a power producing medium.

563. Combustion. One pound of pure carbon burned in air uses 2.67 lb. of oxygen, forming a gas consisting of 3.67 lb. of carbon dioxide and 8.90 lb. of nitrogen.

If insufficient air is supplied, the amount of carbon dioxide decreases, some carbon monoxide being formed. If the air supply is 50 per cent. deficient, no carbon dioxide can (theoretically at least) be formed. With air in excess, additional free oxygen and nitro-

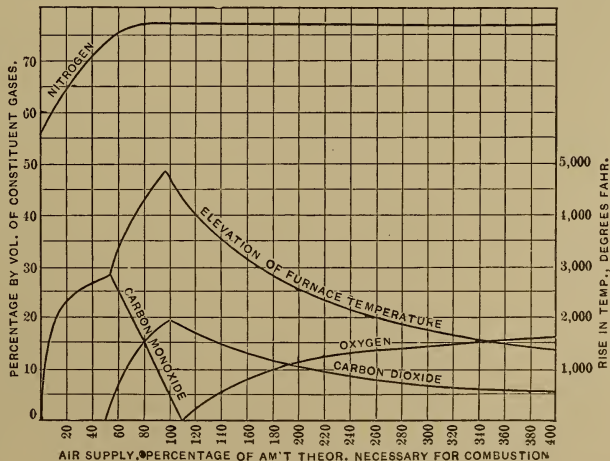

FIG. 273. Arts. 563, 564. — Air Supply and Combustion.

gen will be found in the products of combustion. Figure 273 illustrates the percentage composition by volume of the gases formed by combustion of pure carbon in varying amounts of air. The proportion of carbon dioxide reaches a maximum when the air supply is just right.

564. Temperature Rise. In burning to carbon dioxide, each pound of carbon evolves 14,500 B. t. u. In burning the carbon monoxide, only 4450 B. t. u. are evolved per pound. Let W be the weight of gas formed per pound of carbon, K its mean* specific heat, $T-t$ the elevation of temperature produced; then for combustion to carbon dioxide, $T-t = \frac{14500}{WK}$ and for combustion to carbon monoxide, $T-t = \frac{4450}{WK}$. The rise of temperature is much less in the latter case. As air is supplied in excess, W increases while the other quantities on the right-hand sides of these equations remain constant, so that the temperature rise similarly *decreases*. The temperature elevations are plotted in Fig. 273. The maximum rise of temperature occurs when the air supply is just the theoretical amount.

565. Practical Modifications. These curves truly represent the phenomena of combustion only when the reactions are perfect. In practice, the fuel and air are somewhat imperfectly mixed, so that we commonly find free oxygen and carbon monoxide along with carbon dioxide. The presence of even a very small amount of carbon monoxide appreciably reduces the evolution of heat. The best results are obtained by supplying some excess of air; instead of the theoretical 11.57 lb., about 16 lb. may be supplied, in good practice. In poorly operated plants, the air supply may easily run up to 50 or even 100 lb., the percentage of carbon dioxide, of course, steadily decreasing. Gases

* K is quite variable for wide temperature ranges. (See Art. 63.) In general, it may be written as $a \pm bt$ or as $a \pm bt \pm ct^2$ where a , b and c are constants and t the temperature range from some experimentally set state. For accurate work, then

$$\begin{aligned}
 H &= \int_{t_1}^{t_2} K dt = \int_{t_1}^{t_2} a dt \pm \int_{t_1}^{t_2} b t dt \pm \int_{t_1}^{t_2} c t^2 dt \\
 &= a(t_2 - t_1) \pm \frac{b}{2}(t_2^2 - t_1^2) \pm \frac{c}{3}(t_2^3 - t_1^3),
 \end{aligned}$$

the last term disappearing when K may be written as a function of the first power only of the temperature.

containing 10 per cent of dioxide by volume are usually considered to represent fair operation.

566. Distribution of Heat. Of the heat supplied to the boiler by the fuel, a part is employed in making steam, a small amount of fuel is lost through the grate bars, some heat is transferred to the external atmosphere, and some is carried away by the heated gases leaving the boiler. This last is the important item of loss. Its amount depends upon the weight of gases, their specific heat and temperature. The last factor we aim to fix in the design of the boiler to suit the specific rate of combustion; the specific heat we cannot control; but the *weight of gas* is determined solely by the supply of air, and is subject to operating control.

Efficient operation involves the minimum possible air supply in excess of the theoretical requirement; it is evidenced by the percentage of carbon dioxide in the discharged gases. If the air supply be too much decreased, however, combustion may be incomplete, forming carbon monoxide, and another serious loss will be experienced, due to the potential heat carried off by the gas.

567. Air Supply and Draft. The *draft* necessary is determined by the physical nature of the fuel; the air supply, by its chemical composition. The two are not equivalent; soft coal, for example, requires little draft, but ample air supply. The two should be subject to separate regulation. Low grade anthracite requires ample draft, but the air supply should be closely economized. If forced draft, by steam jet, blower, or exhauster, is employed, the necessary **head** or **pressure** should be provided without the delivery of an excessive **quantity** or **volume** of air.

Drafts required vary from about 0.1 in. of water for free-burning soft coal to 1.0 in. or more for fine anthracite. A chimney is seldom designed for less than 0.5 in., nor forced blast apparatus for less than 0.8 in.

568. Types of Boiler. Boilers are broadly grouped as **fire-tube** or **water-tube**, **internally** or **externally** fired. A type of externally fired water-tube boiler has been shown in Fig. 233. In this, the Babcock and Wilcox design, the path of the gases is as described in Art. 508. The feed water enters the drum 6 at 29, flows downward through the back water legs at *a*, and then upward to the right along the tubes, the high temperature zone at 1 compelling the water above it in tubes to rise. Figure 274 shows the horizontal tubular boiler, probably most generally used in this country. The **fire grate** is at *S*. The gases pass over the **bridge wall** *O*, under the shell of the boiler, up the **back end** *Y*, and to the right through **tubes** running from end to end of the cylindrical **shell**. The tubes terminate at *C*, and

the gases pass up and away. Feed water enters the front head, is carried in the pipe about two thirds of the distance to the back end, and then falls, a compensating

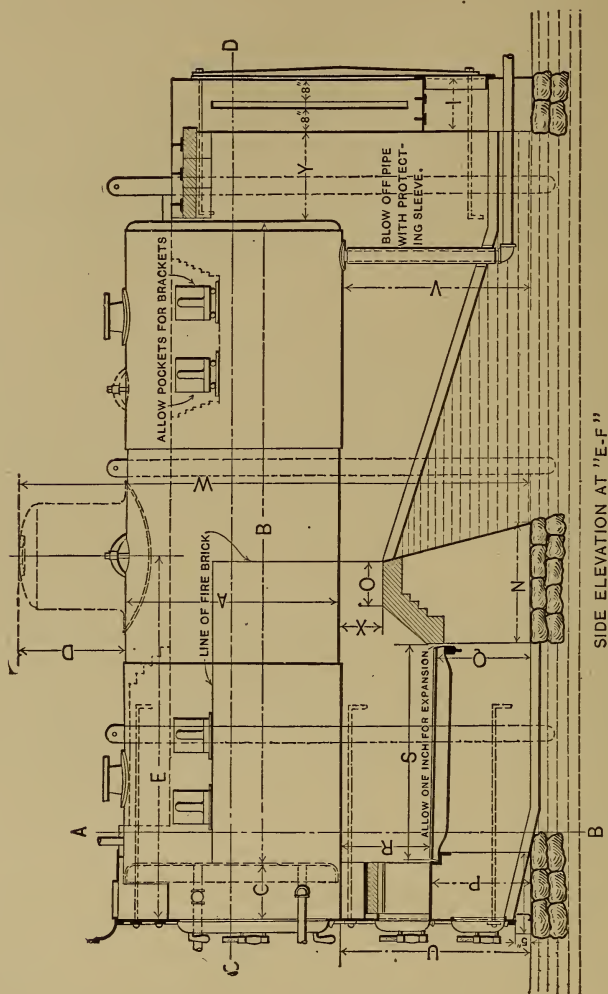

FIG. 274. Art. 568 — Horizontal Tubular Boiler. (The Bigelow Company.)

upward current being generated over the grate. This is an *externally fired* fire-tube boiler. Figure 275 shows the well-known *locomotive boiler*, which is internally fired. The coldest part of this boiler is at the end farthest from the grate, on the exposed sides. The feed is consequently admitted here. Figure 276 shows a boiler commonly used in marine service. The grate is placed in an internal furnace; the gases pass upward in the back end, and return through the tubes. The feed pipe is located as in horizontal tubular boilers.

569. Discussion. The internally fired boiler requires no brick furnace setting, and is compact.

The water-tube boiler is rather safer than the fire-tube, and requires less space. It can be more readily used with high steam pressures. The important points to observe in boiler types are the paths of the gases and of the water. The gases should, for economy, impinge upon and thoroughly circulate about all parts of the heating surface; the circulation of the water for safety and large capacity should be positive and rapid, and the cold feed water should be introduced at such a point as to assist this circulation.

There is no such thing as a "most economical type" of boiler. Any type may be economical if the proportions are right. The grade of fuel used and the draft attainable determine the necessary area of grate for a given fuel consumption. The heating surface must be sufficient to absorb the heat liberated by the fuel. The higher the *rate of combustion* (pounds of fuel burned per square foot of grate per hour), the greater the relative amount of heating surface necessary.

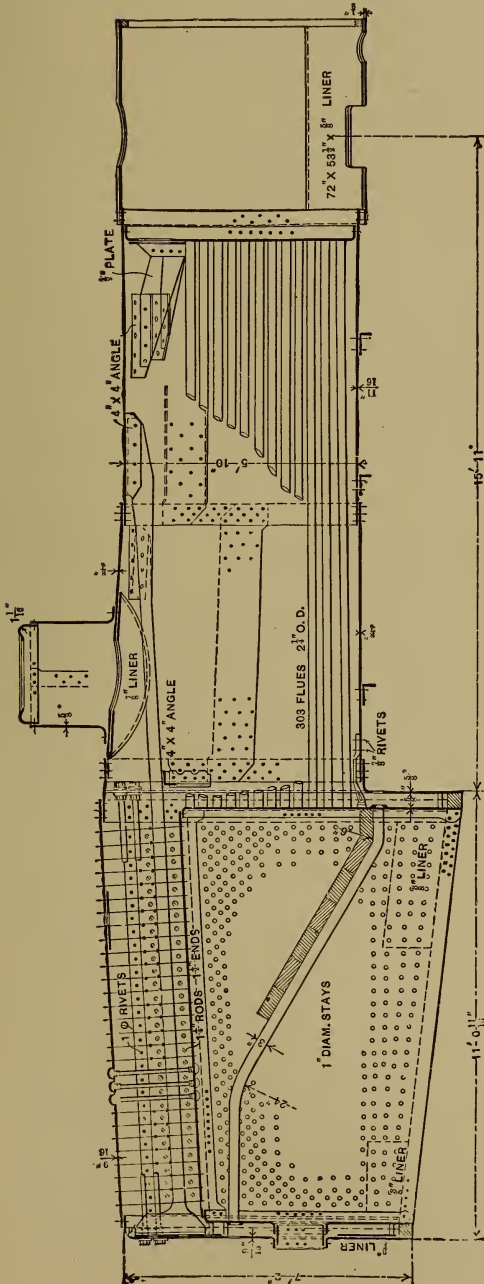

FIG. 275. Art. 568. — Locomotive Boiler. (From Parsons' "Steam Boilers," by permission of Messrs. Longmans, Green, & Co.)

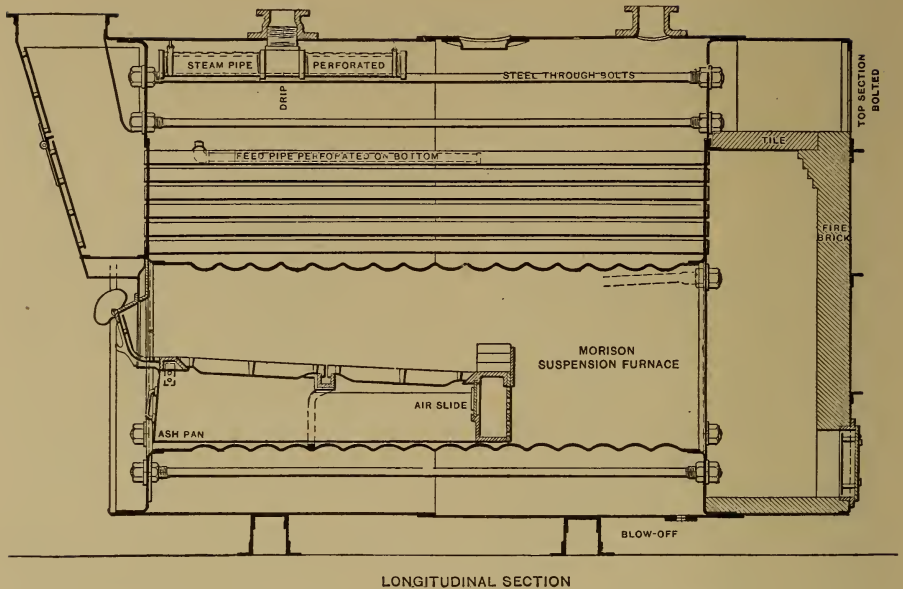

FIG. 276. Art. 568. — Marine Boiler. (The Bigelow Company.)

Rates of combustion range from 12 lb. with low grade hard coal and natural draft up to 30 or 40 lb. with soft coal;* the corresponding ratios of heating surface to grate surface may vary from 30 up to 60 or 70. The best economy has usually been associated with high ratios. The *rate of evaporation* is the number of pounds of water evaporated per square foot of heating surface per hour; it ranges from 3.0 upward, depending upon the activity of circulation of water and gases.† An effective heating surface usually leads to a low flue-gas temperature and relatively small loss to the stack. Small tubes increase the efficiency of the heating surface but may be objectionable with certain fuels. Tubes seldom exceed 20 ft. in length. In water-tube boilers, the arrangement of tubes is important. If the bank of tubes is comparatively wide and shallow, the gases may pass off without giving up the proper proportion of their heat. If the bank is made too high and narrow, the grate area may be

* Much higher rates are attained in locomotive practice; and in torpedo boats, with intense draft, as much as 200 lb. of coal may be burned per square foot of grate per hour.

† Former ideas regarding economical rates of evaporation and boiler capacity are being seriously modified. Bone has found in "surface combustion" with gas fired boilers an efficiency of 0.94 to be possible with an evaporation rate of 21.6 lb. (See *Power*, Nov. 21, 1911, Jan. 16, 1912.)

too much restricted. The gases must not be allowed to reach the flue too quickly.

570. Boiler Capacity. A boiler evaporating 3450 lb. of water per hour from and at 212° F. performs $970.4 \times 778 \times 3450 = 2,600,000,000$ foot-pounds of work, or 1300 horse power. No engine can develop this amount of power from 3450 lb. of steam per hour; the power developed by the engine is very much less than that by the boiler which supplies it. Hence the custom of rating boilers arbitrarily. By definition of the American Society of Mechanical Engineers, a boiler horse power means the evaporation of $34\frac{1}{2}$ lb. of water per hour from and at 212° F. This rating was based on the assumption (true in 1876, when the original definition was established) that an ordinary good engine required about this amount of steam per horse power hour. This evaporation involves the liberation of about 33,000 B. t. u. per hour. Under forced conditions, however, a boiler may often transmit as many as 25 B. t. u. per square foot of surface per hour per degree of temperature difference on the two sides of its surface.

571. Limit of Efficiency. The gases cannot leave the boiler at a lower temperature than that of the steam in the boiler. Let t be the initial temperature of the fuel and air, x the temperature of the steam, and T the temperature attained by combustion; then if W be the weight of gas and K its specific heat, assumed constant, the total heat generated is $WK(T - t)$, the maximum that can be utilized is $WK(T - x)$, and the limit of efficiency is

$$\frac{T - x}{T - t}.$$

In practice, we have as usual limiting values $T = 4850$, $x = 350$, $t = 60$; whence the efficiency is 0.94 — a value never reached in practice.

572. Boiler Trials. A standard code for conducting boiler trials has been published by the American Society of Mechanical Engineers (2). A boiler, like any mechanical device, should be judged by the ratio of the work which it does to the energy it uses. This involves measuring the fuel supplied, determining its heating value, measuring the water evaporated, and the pressure and superheat, or wetness, of the steam. The result is usually expressed in **pounds of dry steam evaporated per pound of coal from and at 212° F.**, briefly called the **equivalent evaporation**.

Let the factor of evaporation be F . If W pounds of water are fed to the boiler per pound of coal burned, the equivalent evaporation is FW .

If C be the heating value per pound of fuel, the **efficiency** is $970 FW \div C$. Many excessively high values for efficiency have been reported in consequence of not correcting for wetness of the steam; the proportion of wetness may range up to 4 per cent in overloaded boilers. The highest well-confirmed figures give boiler efficiencies of about 83 per cent. The average efficiency, considering all plants, probably ranges from 0.40 to 0.60.

573. Checks on Operation. A careful boiler trial is rather expensive, and must often interfere with the operation of the plant. The best indication of current efficiency obtainable is that afforded by analysis of the flue gases. It has been shown that maximum efficiency is attained when the percentage of carbon dioxide reaches a maximum. Automatic instruments are in use for continuously determining and recording the proportion of this constituent present in flue gases.

575. Chimney Draft. In most cases, the high temperature of the flue gases leaving the boiler is utilized to produce a natural upward draft for the maintenance of combustion. At equal temperatures, the chimney gas would be heavier than the external air in the ratio $(n+1) \div n$, where n is the number of pounds of air supplied per pound of fuel. If T, t denote the respective absolute temperatures of air and gas, then, the density of the outside air being 1, that of the chimney gas is $\frac{T}{t} \left(\frac{n+1}{n} \right)$. At 60° F., the volume of a pound of air is 13 cu. ft. The weight of gas in a chimney of cross-sectional area A and height H is then

$$AH \frac{T}{t} \left(\frac{n+1}{n} \right) \div 13.$$

The "pressure head," or draft, due to the difference in weight inside and outside is, per unit area,

$$p = H \left\{ 1 - \frac{T}{t} \left(\frac{n+1}{n} \right) \right\} \div 13.$$

This is in pounds per square foot, if appropriate units are used; drafts are, however, usually stated in "inches of water," one of which is equal to 5.2 lb. per square foot. The force of draft therefore depends directly on the height of the chimney; and since $n+1$ is substantially equal to n , maximum draft is obtained when $T \div t$ is a minimum, or (since T is fixed) when t is a maximum; in the actual case, however, the *quantity of gas passing* would be seriously reduced if the value of t were too high, and best results (3), so far as draft is concerned, are obtained when $t : T :: 25 : 12$.

To determine the *area* of chimney: the velocity of the gases is, in feet per second,

$$v = \sqrt{2gh} = 8.03\sqrt{h} = 8.03\sqrt{\frac{p}{d}},$$

h being the head corresponding to the net pressure p and density d of the gases in the chimney. Also

$$d = \frac{T}{13t} \left(\frac{n+1}{n} \right).$$

Then if C lb. of coal are to be burned per hour, the weight of gases per second is

$$\frac{C(n+1)}{3600}, \text{ their volume is } \frac{C(n+1)}{3600 d},$$

and the area of the chimney, in square feet, is

$$\frac{C(n+1)}{3600 d} \div 8.03 \sqrt{\frac{p}{d}}.$$

A slight increase may be made to allow for decrease of velocity at the sides. The results of this computation will be in line with those of ordinary "chimney tables," if side friction be ignored and the air supply be taken at about 75 lb. per pound of fuel.

576. Mechanical Draft. In lieu of a chimney, steam-jet blowers or fans may be employed. These usually cost less initially, and more in maintenance. The ordinary steam-jet blower is wasteful, but the draft is independent of weather conditions, and may be greatly augmented in case of overload. The velocity of the air moved by a fan is

$$v = \sqrt{2gh},$$

where h is the head due to the velocity, equal to the pressure divided by the density. Then

$$v = \sqrt{2g \frac{p}{d}} \text{ and } p = \frac{v^2 d}{2g}.$$

If a be the area over which the discharge pressure p is maintained, the work necessary is

$$W = pav = dav^3 \div 2g.$$

We may note, then, that the velocity of the air and the amount delivered vary as the **peripheral speed of the wheel**, its pressure as the **square**, and the power consumed as the **cube**, of that speed. Low peripheral speeds are therefore economical in power. They are usually fixed by the pressure required, the fan width being then made suitable to deliver the required volume.

577. Forms of Fan Draft. The air may be blown into a closed fire room or ash pit or the flue gases may be sucked out by an **induced draft fan**. In the last case, the high temperature of the gases reduces the capacity of the fan by about one half; *i.e.*, only one half the weight of gas will be discharged that would be delivered at 60° F. Since the density is inversely proportional to the absolute temperature, the required pressure can then be maintained only at a considerable increase in peripheral speed; which is not, however, accompanied by a concordant increase in power consumption. Induced draft requires the handling of a greater weight, as well as of a greater volume of gas, than forced draft; the necessary pressure is somewhat greater, on account of the frictional resistance of the flues and passages; high temperatures lead to mechanical difficulties with the fans. The difficulty of regulating forced draft has nevertheless led to a considerable application of the induced system.

578. Furnaces for Soft Coal; Stokers. Mechanical stokers are often used when soft coal is employed as fuel. Besides saving some labor, in large plants at least, they give more perfect combustion of hydrocarbons, with reduced smoke produc-

tion. Figure 277 shows, incidentally, a modern form of the old "Dutch oven" principle for soft coal firing. The flames are kept hot, because they do not strike the relatively cold boiler surface until combustion is complete. Fuel is fed alternately to the two sides of the grate, so that the smoking gases from one side meet the hot flame from the other at the hot baffling "wing walls" *a*, *b*. The principle

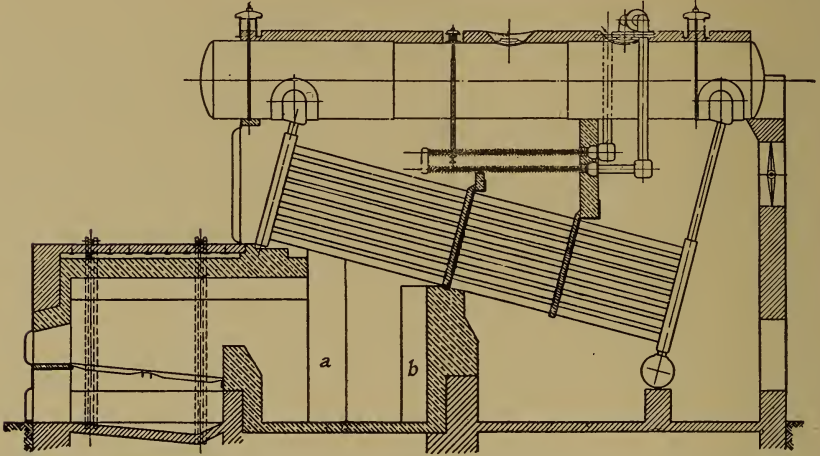

FIG. 277. Arts. 578, 579. — Sectional Elevation of Foster Superheater combined with Boiler and Kent Wing Wall Furnace. (Power Specialty Company.)

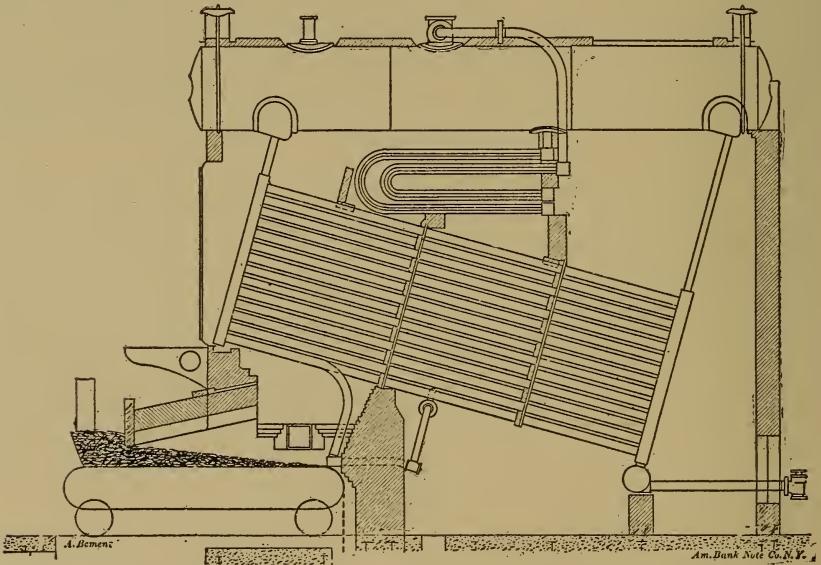

FIG. 278. Arts. 578, 579. — Babcock and Wilcox Boiler with Chain Grate Stoker and Superheater.

involved in the attempt to abate smoke is that of all mechanical stokers, which may be grouped into three general types. In the *chain grate*, coal is carried forward continuously on a moving chain, the ashes being dropped at the back end. The gases from the fresh fuel pass over the hotter coke fire on the back portion of the grate. (See Fig. 278.) The second type comprises the *inclined grate* stokers. The high combustion chamber above the lower end of the grate is a decided advantage with many types of boilers. The smoke is distilled off at the "coking plate." The *underfeed* stoker feeds the coal by means of a worm to the under side of the fire, and the smoke passes through the incandescent fuel. All stokers have the advantage of making firing continuous, avoiding the chilling effect of an open fire door. Among soft coal furnaces not associated with stokers, one of the best known is the Hawley down draft. In this, there are two grates, coal being fired on the upper, through which the draft is downward. Partially consumed particles of coal (coke) fall through the bars to the lower grate, where they maintain a steady high temperature zone through which the smoking gases from the upper grate must pass on their way to the flue.

579. Superheaters; Types. Superheating was proposed at an early date, and given a decided impetus by Hirn. After 1870, as higher steam pressures were introduced, superheating was partially abandoned. Lately, it has been reintro-

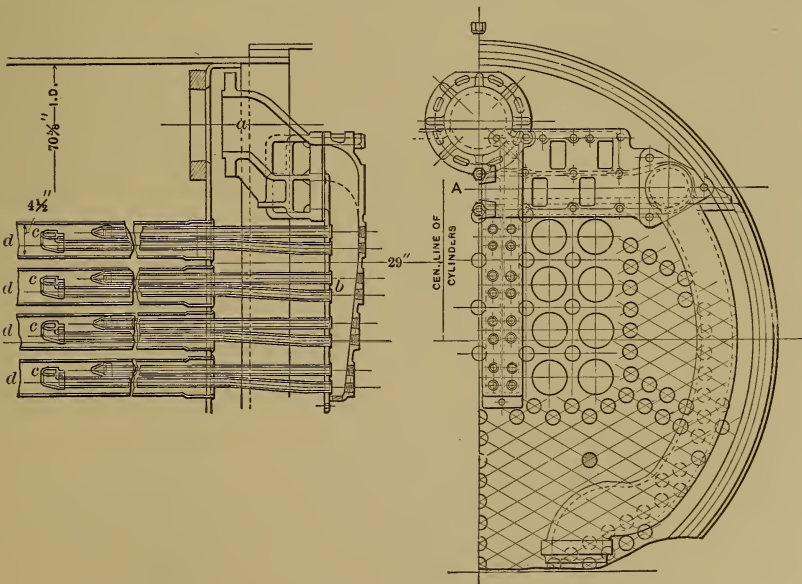

FIG. 279. Art. 579. — Cole Superheater. (American Locomotive Company.)

duced, and the use of superheat is now standard practice in France and Germany, while being quite widely approved in this country. Superheaters may be separately fired, steam from a boiler being passed through an entirely separate machine, or, as is more common, steam may be carried away from the water to some space

provided for it within the boiler setting or flue, and there heated by the partially spent gases. When it is merely desired to *dry* the steam, the "superheater" may be located in the flue, using waste heat only. When any considerable increase of temperature is desired, the superheater should be placed in a zone of the furnace where the temperature is not less than 1000° F. With a difference in mean temperature between gases and steam of 400° F., from 4 to 5 B. t. u. may be transmitted per degree of mean temperature difference per square foot of surface per hour (4). According to Bell, if S = amount of superheat, deg. F., T = temperature

of flue gases reaching superheater, t = temperature of saturated steam, x = sq. ft. of superheater surface per boiler horse power;

$$x = \frac{10S}{2(T-t) - S}$$

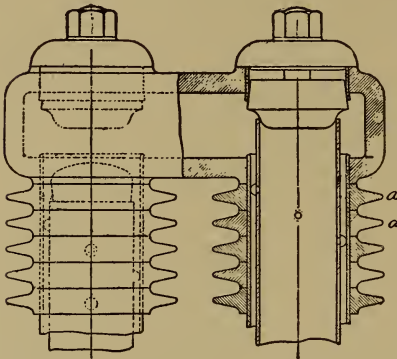

FIG. 280. Art. 579.—Superheater Element.
(Power Specialty Company.)

The location of the Babcock and Wilcox superheater is shown in Fig. 277; a similar arrangement, in which the chain grate stoker is incidentally represented, is shown in Fig. 278. In locomotive service (in which superheat has produced unexpectedly large savings) Field tubes may be employed, as in Fig. 279, the steam emerging from the boiler at a , and passing through the header b to the small tubes c, c , in the fire tubes d, d (5).

A typical superheater tube or "element" is shown in Fig. 280. This is made double, the steam passing through the annular space. Increased heating surface is afforded by the cast iron rings a, a . In some single-tube elements, the heating surface is augmented by internal longitudinal ribs. The tubes should be located so that the wettest steam will meet the hottest gases.

580. Feed-water Heaters. In Fig. 233, the condensed water is returned directly from the hot well 24, by way of the feed pump IV, to the boiler. This water is seldom higher in temperature than 125° F. A considerable saving may be effected by using exhaust steam to further heat the water before it is delivered to the boiler. The device for accomplishing this is called the **feed-water heater**. With a condensing engine, as shown, the water supply may be drawn from the hot well and the necessary exhaust steam supplied by the auxiliary exhausts 27 and 31; 1 lb. of steam at atmospheric pressure should heat about 9.7 lb. of water through 100°. Accurately, $W(xL + h - q_c) = w(Q - q)$, in which W is the weight of steam condensed, x is its dryness, L its latent heat, h its heat of liquid, and w is the weight of feed water, the initial and final heat contents of which are respectively q and Q . The heat contents of the steam after condensation are q_0 . Then

$$w = \frac{W(xL - q_0)}{Q - q}$$

With non-condensing engines, the exhaust steam from the engines themselves is used to heat the cold incoming water.

581. Types. Feed-water heaters may be either "open," the steam and water mixing, or "closed," the heat being transmitted through the surface of straight or curved tubes, through which the water circulates. Figure 281 shows a closed heater; steam enters at *A* and emerges at *B*, water enters at *C*, passes through the tubes and out at *D*. The openings *E, E* are for drawing off condensed steam. An open heater is shown in Fig. 282. Water enters through the automatically controlled valve *a*, steam enters at *b*. The water drips over the trays, becoming finely divided and effectively heated by the steam. At *c* there is provided storage space for the mixture, and at *d* is a bed of coke or other absorbent material, through which the water filters upward, passing out at *e*. The open heater usually makes the water rather hotter, and lends itself more readily to the reclaiming of hot drips from the steam pipes, returns from heating systems, etc., than a heater of the closed type. Live steam is sometimes used for feed-water heating; the greater effectiveness of the boiler-heating surface claimed to arise from introducing the water at high temperature has been disputed (6); but the high temperatures possible with live steam are of decided value in removing dissolved solids, and the waste of steam may be only slight. Closed heaters are, of course, used for this service, as also with the isodiabatic multiple expansion cycle described in Art. 550. Removal of some of the suspended and dissolved

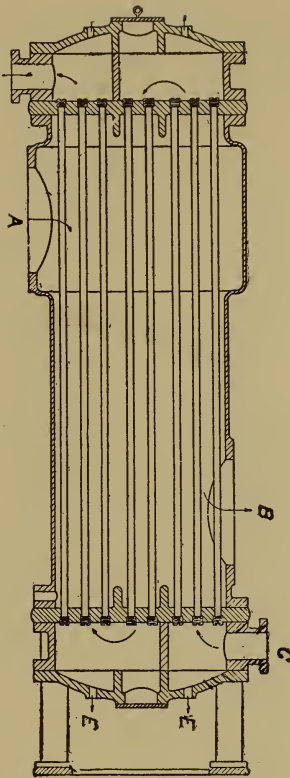

FIG. 281. Art. 581.—Wheeler Feed Water Heater.

solids is also possible in ordinary open-exhaust steam heaters. Various forms of feed-water filters are used, with or without heaters.

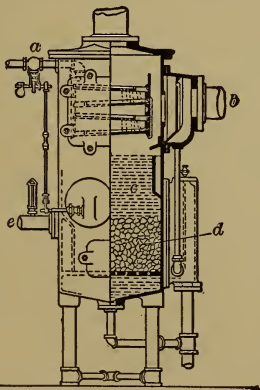

FIG. 282. Art. 581.—Open Feed Heater.

(Harrison Safety Boiler Works.)

582. The Economizer. This is a feed-water heater in which the heating medium is the waste gas discharged from the boiler furnace. It may increase the feed temperature to 300° F. or more, whereas no ordinary exhaust steam heater can produce a temperature higher than 212° F. The gain by heating feed water is about 1 B. t. u. per pound of water for each degree heated; or since average steam contains 1000 B. t. u. net, it is about 1 per cent for each 10° that the temperature is raised; precisely, the gain is $(H - h) \div Q$, in which Q is the total heat of the steam gained from the temperature of feed to the state at evaporation and h and H the total heats in the water before and after heating. If T, t be the temperatures

of flue gases and steam, respectively, W the weight, and K the mean specific heat of the gases (say about 0.24), then the maximum saving that can be effected by a

perfect economizer is $WK(T-t)$. Good operation decreases W and T and thus makes the possible saving small. A typical economizer installation is shown in Fig. 283; arrangement is always made for by-passing the gases, as shown, to permit of inspecting and cleaning. The device consists of vertical cast-iron tubes with connecting headers at the ends, the tubes being sometimes staggered so that the gases will impinge against them. The external surface of the tubes is kept clean by scrapers, operated from a small steam engine. The tubes obstruct the draft, and some form of mechanical draft is employed in conjunction with economizers. From $3\frac{1}{2}$ to 5 sq. ft. of economizer surface are ordinarily used per boiler horse power. The rate of heat transmission (B. t. u. per square foot per degree of mean temperature difference per hour) is usually around 2.0.

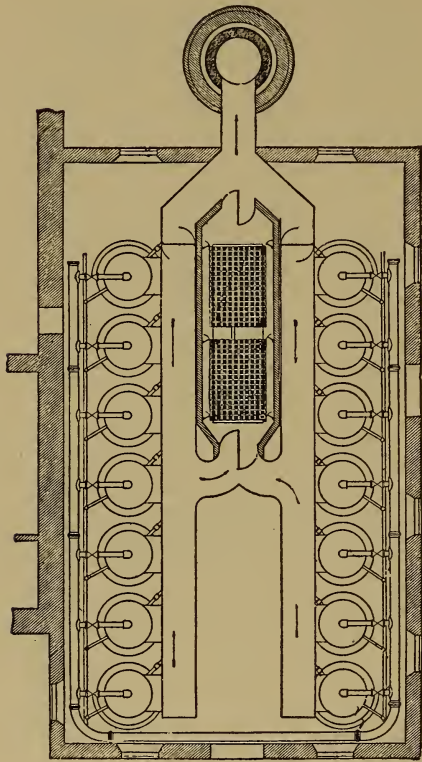
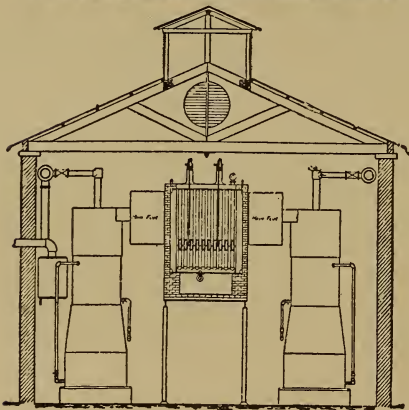

Fig. 582. — Green Fuel Economizer.



and the down pipe then forms a radiating coil, in which a considerable amount of condensation occurs. The weight of this column of water in the down pipe offsets

583. Miscellaneous Devices.

A steam separator is usually placed on the steam pipe near the engine. This catches and more or less thoroughly removes any condensed steam, which might otherwise cause damage to the cylinder. Steam meters are being introduced for approximately indicating the amount of steam flowing through a pipe. Some of them record their indications on a chart. Feed-water measuring tanks are sometimes installed, where periodical boiler trials are a part of the regular routine. The steam loop is a device for returning condensed steam direct to the boiler. The drips are piped up to a convenient height,

a corresponding difference in pressure, and permits the return of drips to the boiler even when their pressure is less than the boiler pressure. The ordinary **steam trap** merely removes condensed water without permitting the discharge of uncondensed steam. **Oil separators** are sometimes used on exhaust pipes to keep back any traces of cylinder oil.

584. Condensers. The theoretical gain by running condensing is shown by the Carnot formula $(T-t) \div T$. The gain in practice may be indicated on the PV diagram, as in Fig. 284. The shaded area represents work gained due to condensation; it may amount to 10 or 12 lb. of mean effective pressure, which means about a 25 per cent gain, in the case of an ordinary simple engine.* This gain is principally the result of the introduction of cooling water, which usually costs merely the power to pump it; in most cases, some additional power is needed to drive an air pump as well.

In the *surface condenser* the steam and the water do not come into contact, so that impure water may be used, as at sea, even when the condensed steam is returned to the boilers.† Such a condenser needs both *air* and *circulating* pumps. The former ordinarily carries away air, vapor and condensed steam. In some cases, the discharge of condensed steam is separately cared for and the *dry vacuum* pump (which should always be piped to the condenser at a point as far as possible from the steam inlet thereto) handles only air and vapor.

The amount of condensing surface should be computed from Orrok's formula (*Jour. A. S. M. E.*, XXXII, 11):

$$U = 630 \frac{Cr^{5m}\sqrt{V}}{T_m^{\frac{1}{2}}}$$

where U = B. t. u. transmitted per sq. ft. of surface per hour per degree of mean temperature difference between steam and water;

C = a cleanliness coefficient (tubes), between 1.0 and 0.5;

r = ratio of partial pressure of steam to the total absolute pressure in the condenser, depending on the amount of air present, and varying from 1.0 to 0;

m = a coefficient depending upon the material of the tubes; 1.0 for copper, 0.63 for Shelby steel, 0.98 for admiralty, etc., ranging down to 0.17 for a tube vulcanized on both sides, all of these figures being for new metal. Corrosion or pitting may reduce the value of m 50 per cent;

V = velocity of water in tubes, ft. per sec., usually between 3 and 12;

T_m = mean temperature difference between steam and water, deg. F. For $T_m = 18.3$ (corresponding with 28" vacuum, 70° temperature of inlet water, 90° temperature of outlet water), this becomes $435Cr^5m\sqrt{V}$. The former approximate expression of Whitham (7) was

$$S = WL \div 180(T-t),$$

* In the case of the turbine, good vacuum is so important a matter that extreme refinement of condenser design has now become essential.

† There is always an element of danger involved in returning condensed steam from reciprocating engines to the boilers, on account of the cylinder oil which it contains.

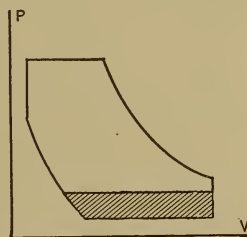

FIG. 284. Art. 584.—Saving Due to Condensation.

where S was the condenser surface in sq. ft., W the weight of steam condensed, lb. per hour, L the latent heat at the temperature T of the steam, and t the mean temperature of circulating water between inlet and outlet. With the same notation, Orrok's formula gives

$$S = \frac{WL}{UT_m} = \frac{WL}{U(T-t)}, \text{ nearly.}$$

With $C=0.8$, $r=0.8$, $m=0.50$, $T_m=18.2$, $V=16$, U becomes approximately 180, as in the Whitham formula.

Let u , U be the initial and final temperatures of the water; then the weight w of water required per hour is $WL \div (U-u)$. The weight of water is often permitted to be about 40 times the weight of steam, a considerable excess being desirable. The outlet temperature of the water in ordinary surface condensers will be from 15° to 40° below that of the steam. The direction of flow of the water should be opposite to that of the steam.

The *jet condenser* is shown in Fig. 285. The steam and water mix in a chamber above the air pump cylinder, and this cylinder is utilized to draw in the water, if the lift is not excessive. Here $U=T$; the supply of water necessary is less than in surface condensers. With ample water supply, the surface condenser gives the better vacuum. The boilers may be fed from the hot well, as in Fig. 233 (which shows a jet condenser installation), only when the condensing water is pure.

The *siphon condenser* is shown in Fig. 286. Condensation occurs in the nozzle, a , and the fall of water through b produces the vacuum. To preserve this, the lower end of the discharge pipe must be sealed as shown. The vacuum would draw water up the pipe b and permit it to flow over into the engine, if it were not that the length cd is made 34 ft. or more, thus giving a height to which the atmospheric pressure cannot force the water. Excellent results have been obtained with these condensers without vacuum pumps. In some cases, however, a "dry" vacuum pump is used to remove air and vapor from above the nozzle. The device is then called a *barometric condenser*. The vacuum will lift the inlet water about 20 ft., so that, unless the suction head is greater than this, no water supply pump is required after the condenser is started.

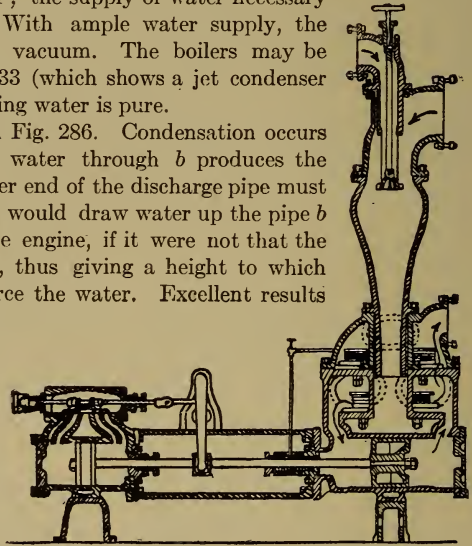

FIG. 285. Art. 584.—Horizontal Independent Jet Condenser.

Either the jet or the siphon (or barometric) condenser requires a larger air pump than a surface condenser. Experience has shown that there will be present 1 cu. ft. of free air (Art. 187) per 10 to 50 cu. ft. of water entering the air pump of a surface condenser or per 30 to 150 cu. ft. of water entering a jet or barometric condenser. The surface condenser air pump handles the condensed steam only; the other condensers add the circulating water (which may be 20 to 40 times this) to the steam. The volume of air at the low absolute pressure prevailing in the condenser is large, and the necessity for reducing the partial pressure due to air has led to the employment of pumps still larger than the influence of air volume, alone would warrant.

(For a discussion of air pump design and the importance of clearance in connection with high vacuums, see Cardullo, *Practical Thermodynamics*, 1911, p. 210.)

585. Evaporative Condensers; Cooling Towers. Steam has occasionally been condensed by allowing it to pass through coils over which fine streams of water trickled. The evaporation of the water (which may be hastened by a fan) cools the coils and condenses the steam, which is drawn off by an air pump. With ordinary condensers and a limited water supply **cooling towers** are sometimes used. These may be identical in construction with the evaporative condensers, excepting that warm water enters the coils instead of steam, to be cooled and used over again; or they may consist of open wood mats over which the water falls as in the open type of feed-water heater. Evaporation of a portion of the water in question (which need not be a large proportion of the whole) and warming of the air then cools the remainder of the water, the cooling being facilitated by placing the mats in a cylindrical tower through which there is a rapid upward current of air, naturally or artificially produced (8). The cooling pond (8a) is equivalent to a tower.

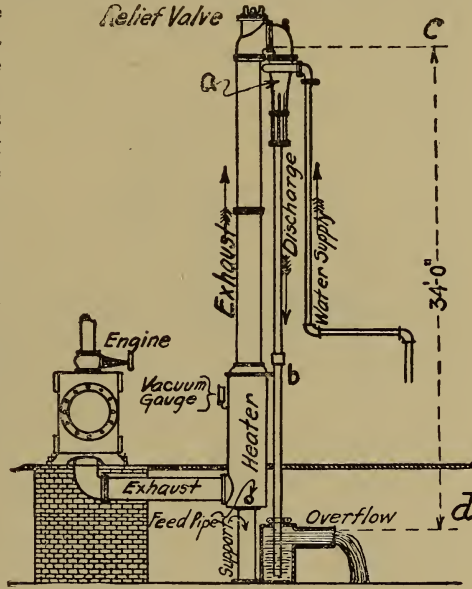

FIG. 286. Art. 584.—Bulkley Injector Condenser.

586. Boiler Feed Pump. This may be either steam-driven or power-driven (as may also be the condenser pumps). Steam-driven pumps should be of the duplex type, with plungers packed from the outside, and with individually accessible valves. If they are to pump hot water, special materials must be used for exposed parts. The power pump has usually three single-acting water cylinders. There is much discussion at the present time as to the comparative economy of steam- and power-driven auxiliaries. The steam engine portion of an ordinary small pump is extremely inefficient, while power-driven pumps can be operated, at little loss, from the main engines. The general use of exhaust steam from auxiliaries for feed-water heating ceases to be an argument in their favor when economizers are used; and in large plants the difference in cost of attendance in favor of motor-driven auxiliaries is a serious item.

587. The Injector. The pump is the standard device for feeding stationary boilers; the injector, invented by Giffard about 1858, is used chiefly as an auxiliary, although still in general application as the prime feeder on locomotives. It

consists essentially of a steam nozzle, a combining chamber, and a delivery tube. In Fig. 287, steam enters at *A* and expands through *B*, the amount of expansion being regulated by the valve *C*. The water enters at *D*, and condenses in *E*. We have here a rapid adiabatic expansion, as in the turbine; the velocity of the water is augmented by the impact of the steam, and is in turn converted into pressure at *F*. In starting the injector, the water is allowed to flow away through *G*; as soon as the velocity is sufficient, this overflow closes. An injector of this form will lift the water from a reasonably low suction level; when the water flows to the device by gravity, the valve *C* may be omitted.

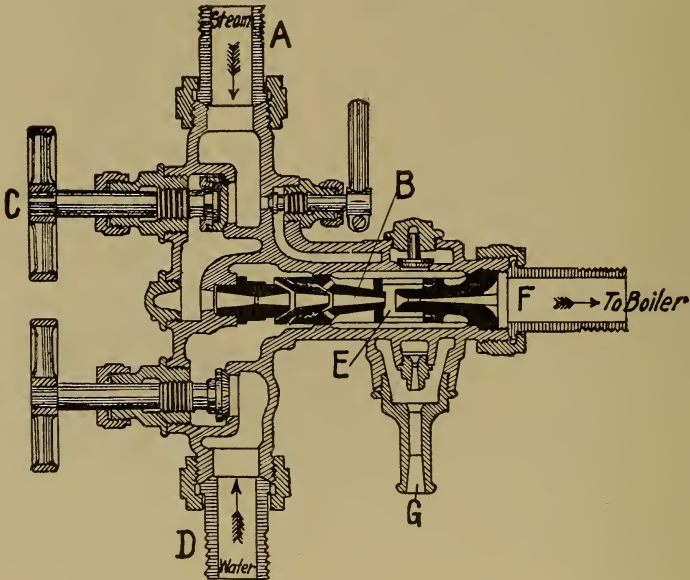

FIG. 287. Art. 587. — Injector.

A self-starting injector is one in which the adjustment of the overflow at *G* is automatic. The ejector is a similar device by which the lifting of water from a well or pit against a moderate delivery head (or none) is accomplished. The siphon condenser (Art. 584) involves an application of the injector principle. The double injector is a series of successive injectors, one discharging into another.

588. Theory. Let x , L , h be the state of the steam, H the heat in the water, and v its velocity; Q the heat in the discharged water at its velocity V . The heat in one pound of steam is $xL + h$; the heat in one pound of water supplied is H , and its kinetic energy $v^2 \div 2g$; the heat in one pound of discharge is Q , and its kinetic energy $V^2 \div 2g$. Let each pound of steam draw in y pounds of water; then

$$xL + h + y\left(H + \frac{v^2}{2g}\right) = (1 + y)\left(Q + \frac{V^2}{2g}\right).$$

The values of $\frac{v^2}{2g}$ and $\frac{V^2}{2g}$ may ordinarily be neglected, and

$$y = \frac{xL + h - Q}{Q - H}.$$

In another form, $y(Q - H) = xL + h - Q$, or the heat gained by the water equals that lost by the steam. This, while not rigidly correct, on account of the changes in kinetic energy, is still so nearly true that the thermal efficiency of the injector may be regarded as 100 per cent; from this standpoint, it is merely a live-steam feed-water heater.

589. Application. The formula given shows at once the relation between steam state, water temperature, and quantity of water per pound of steam. As the water becomes initially hotter, less steam is required; but injectors do not handle hot water well. Exhaust steam may be used in an injector: the pressure of discharge is determined by the velocity induced, and not at all by the initial pressure of the steam; a large steam nozzle is required, and the exhaust injector will not ordinarily lift its own water supply.

590. Efficiency. Let S be the head against which discharge is made; then the work done per pound of steam is $(1 + y)S$ foot-pounds; the efficiency is $S(1 + y) \div (xL + h - Q)$, ordinarily less than one per cent.

This is of small consequence, as practically all of the heat not changed to work is returned to the boiler. Let W be the velocity of the steam issuing from the nozzle; then, since the momentum of a system of elastic bodies remains constant during impact, $W + yv = (1 + y)V$. The value of W may be expressed in terms of the heat quantities by combining this equation with that in Art. 588. The other velocities are so related to each other as to give orifices of reasonable size. The practical proportioning of injectors has been treated by Kneass (9).

(1) Finlay, *Proc. A. I. E. E.*, 1907. (2) *Trans. A. S. M. E.*, XXI, 34. (3) Rankine, *The Steam Engine*, 1897, 289. (4) Longridge, *Proc. Inst. M. E.*, 1896, 175. (5) *Trans. A. S. M. E.*, XXVIII, 10, 1606. (6) Bilbrough, *Power*, May 12, 1908, p. 729. (7) *Trans. A. S. M. E.*, IX, 431. (8) Bibbins, *Trans. A. S. M. E.*, XXXI, 11; Spangler, *Applied Thermodynamics*, 1910, p. 152. (8a) Cardullo, *Practical Thermodynamics*, 1911, p. 264. (9) *Practice and Theory of the Injector*.

SYNOPSIS OF CHAPTER XVI

Hard coal requires high draft; *soft coal*, a high rate of air supply.

In spite of its higher cost, *commercial factors* sometimes make soft coal the cheaper fuel.

Heating values: *fuel oil*, 18,000; *wood*, 6500-8500; *coals*, 8800-15,000; B. t. u. per lb. Method of computing heat value.

The *proportion of carbon dioxide in the flue gases* reaches a maximum when the air supply is just right; this is also the condition of maximum temperature and theoretical efficiency.

Advance in steam power economy is a matter of regulation of air supply; economy may be indicated by automatic records of carbon dioxide.

Types of boiler: water-tube, horizontal tubular, locomotive, marine; conditions of efficiency.

Attention should be given to the *circulation* of the gases and water.

A boiler hp. = $34\frac{1}{2}$ lb. of water per hour from and at 212° F., approximately 33,000 B. t. u. per hour.

Limit of efficiency = $\frac{T-x}{T-t}$; say 0.94; never reached in practice.

Boiler efficiency = $\frac{\text{heat in steam}}{\text{heat in fuel}}$ usually 0.40 to 0.60; may be 0.83.

Furnace efficiency = $\frac{\text{heat in gases}}{\text{heat in fuel}}$ Heating surface efficiency = $\frac{\text{heat in steam}}{\text{heat in gases}}$.

Chimney draft = $H \left\{ 1 - \frac{T}{t} \left(\frac{n+1}{n} \right) \right\} \div 13$; area = $\frac{C(n+1)}{3600d} \div 8.03\sqrt{\frac{p}{d}}$.

Fan draft: $v = \sqrt{2gh}$, $p = \frac{v^2d}{2g}$, $W = \frac{dav^3}{2g}$; slow speeds advantageous.

In *induced draft*, the fan is between the furnace and the chimney; in *forced draft*, it delivers air to the ash pit.

Mechanical *stokers* (inclined grate, chain grate, underfeed), used with soft coal, aim to give space for the hydrocarbonaceous flame without permitting it to impinge on cold surfaces.

Superheaters may be located in the flue, or, if much superheating is required, may be separately fired. About 5 B. t. u. may be the transmission rate.

Feed-water heaters may be *open* or *closed*: $w = \frac{W(xL - q_0)}{Q - q}$; for open heaters, $q_0 = Q$.

The *economizer* uses the waste heat of the flue gases: saving per pound of fuel = $WK(T-t)$. From $3\frac{1}{2}$ to 5 sq. ft. of surface per boiler hp.

Condensers may be surface, jet, evaporative, or siphon; $w = WL \div (U-u)$;

$S = WL \div U(T-t)$; $U = 630 \frac{Cr^5m\sqrt{V}}{T_m^{\frac{1}{2}}}$. The siphon condenser may operate without a vacuum pump.

The use of *steam-driven auxiliaries* affords exhaust steam for feed-water heating.

The *injector* converts heat energy into velocity: $y = \frac{xL+h-Q}{Q-H}$; efficiency = $\frac{S(1+y)}{xL+h-Q}$; $W+yv = (1+y)V$.

PROBLEMS

1. One pound of pure carbon is burned in 16 lb. of air. Assuming reactions to be perfect, find the percentage composition of the flue gases and the rise in temperature, the specific heats being, CO_2 , 0.215; N, 0.245; O, 0.217.

2. A boiler evaporates 3000 lb. of water per hour from a feed-water temperature of 200° F. to dry steam at 160 lb. pressure. What is its horse power?

3. In Problem 1, what proportion of the whole heat in the fuel is carried away

in the flue gases, if their temperature is 600°F ., assuming the specific heats of the gases to be constant? The initial temperature of the fuel and air supplied is 0°F .

4. The boiler in Problem 2 burns 350 lb. of coal (14,000 B. t. u. per pound) per hour. What is its efficiency?

5. In Problem 1, if the gas temperature is 600°F ., the air temperature 60°F ., compare the densities of the gases and the external air. What must be the height of a chimney to produce, under these conditions, a draft of 1 in. of water? Find the diameter of the (round) chimney to burn 5000 lb. of coal per hour. (Assume a 75 lb. air supply in finding the diameter.)

6. Two fans are offered for providing draft in a power plant, 15,000 cu. ft. of air being required at $1\frac{1}{4}$ oz. pressure per minute. The first fan has a wheel 30 in. in diameter, exerts 1 oz. pressure at 740 r. p. m., delivers 405 cu. ft. per minute, and consumes 0.16 hp., both per inch of wheel width and at the given speed. The second fan has a 54-inch wheel, runs at 410 r. p. m. when exerting 1 oz. pressure, and delivers 726 cu. ft. per minute with 0.29 hp., both per inch of wheel width and at the given speed. Compare the widths, speeds, peripheral speeds, and power consumptions of the two fans under the required conditions.

7. Dry steam at 350°F . is superheated to 450°F . at 135 lb. pressure. The flue gases cool from 900°F . to 700°F . Find the amount of superheating surface to provide for 3000 lb. of steam per hour, and the weight of gas passing the superheater. If 180 lb. of coal are burned per hour, what is the air supply per pound of coal?

8. Water is to be raised from 60°F . to 200°F . in a feed-water heater, the weight of water being 10,000 lb. per hour. Heat is supplied by steam at atmospheric pressure, 0.95 dry. Find the weight of steam condensed (*a*) in an open heater, (*b*) in a closed heater. Find the surface necessary in the latter (Art. 584).

9. In Problem 3, what would be the percentage of saving due to an economizer which reduced the gas temperature to 400°F .?

10. An engine discharges 10,000 lb. per hour of steam at 2 lb. absolute pressure, 0.95 dry. Water is available at 60°F . Find the amount of water supplied for a jet condenser. Find the amount of surface, and the water supply, for a surface condenser in which the outlet temperature of the water is 85°F . If the surface condenser is operated with a cooling tower, what weight of water will theoretically be evaporated in the tower, assuming the entire cooling to be due to such evaporation. (N. B. A large part of the cooling is in practice effected by the air.)

11. Find the dimensions of the cylinders of a triplex single-acting feed pump to deliver 100,000 lb. of water per hour at 60°F . at a piston speed of 100 ft. per minute and 30 r. p. m.

12. Dry steam at 100 lb. pressure supplies an injector which receives 3000 lb. of water per hour, the inlet temperature of the water being 60°F . Find the weight of steam used, if the discharge temperature is 165°F .

13. In Problem 12, the boiler pressure is 100 lb. What is the efficiency of the injector, considered as a pump?

14. In Problem 12, the velocity of the entering water is 12 ft. per second, that of the discharge is 114 ft. per second. Find the velocity of the steam leaving the discharge nozzle.

15. What is the relation of *altitude* to chimney draft? (See Problem 12, Chapter XIII.)

16. Circulating water pumped from a surface condenser to a cooling tower loses $4\frac{1}{2}$ per cent of its weight by evaporation and is cooled to 88° F. If the loss is made up by city water at 55° , fed continuously, what is the temperature of the water entering the condenser?

17. Steam at 100 lb. absolute pressure and 500° F. is used in an open feed-water heater to warm water from 60° to 210° . How much water will be heated by 1 lb. of steam?

18. Steam at 150 lb. absolute pressure, 2 per cent wet, passes through a superheater which raises its temperature to 500° F. How much heat was added to each lb. of steam?

19. 20,000 lb. of steam at 150 lb. absolute pressure, 2 per cent wet, are superheated 200° in a separately-fired superheater of 0.70 efficiency. What weight of coal, containing 14,000 B. t. u. per lb., will be required?

CHAPTER XVII

DISTILLATION — FUSION — LIQUEFACTION OF GASES

VACUUM DISTILLATION

591. The Still. Figure 288 represents an ordinary still, as used for purifying liquids or for the recovery of solids in solution by concentration. Externally applied heat evaporates the liquid in *A*, which is condensed at

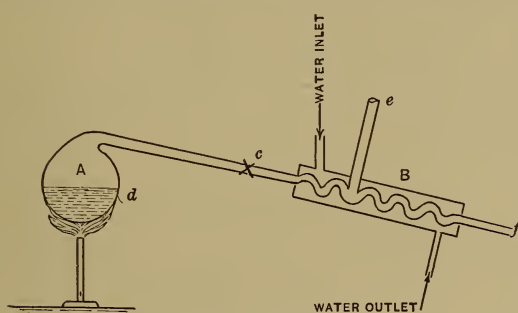

FIG. 288. Art. 591. — Still.

B. All of the heat absorbed in *A* is given up at *B* to the cooling water; the only wastes, in theory, arise from radiation. Conceive the valve *c* to be closed, and the space from the liquid level *d* to this valve to be filled with saturated vapor, no air being present in any part of the apparatus. Then when the

value *c* is opened, a vacuum will gradually be formed throughout the system, and evaporation will proceed at lower and lower temperatures.

Since the total heat of saturated vapor decreases with decrease of pressure, evaporation will thus be facilitated. In practice, however, the apparatus cannot be kept free from air; and, notwithstanding the operation of the condenser, the vacuum would soon be lost, the pressure increasing above that of the atmosphere. This condition is avoided by the use of a vacuum pump, which may be applied at *e*, removing air only; or, in usual practice, at *f*, removing the condensed liquid as well. Evaporation now proceeds continuously at low pressure and temperature. The possibility of utilizing low-temperature heat now leads to marked economy.

Solutions are usually assumed to contain about 5 per cent of their volume of free air. The condenser, if of the jet type, should be designed to handle about 150 times the water volume of actual air; if of the surface type (which must be used when the distilled product is to be recovered), about 100 times the water volume.

592. Application. Vacuum distillation is employed on an important scale in sugar refineries, soda process paper-pulp mills, glue works, glucose factories, for the preparation of pure water, and in the manufacture of gelatine, malt extract,

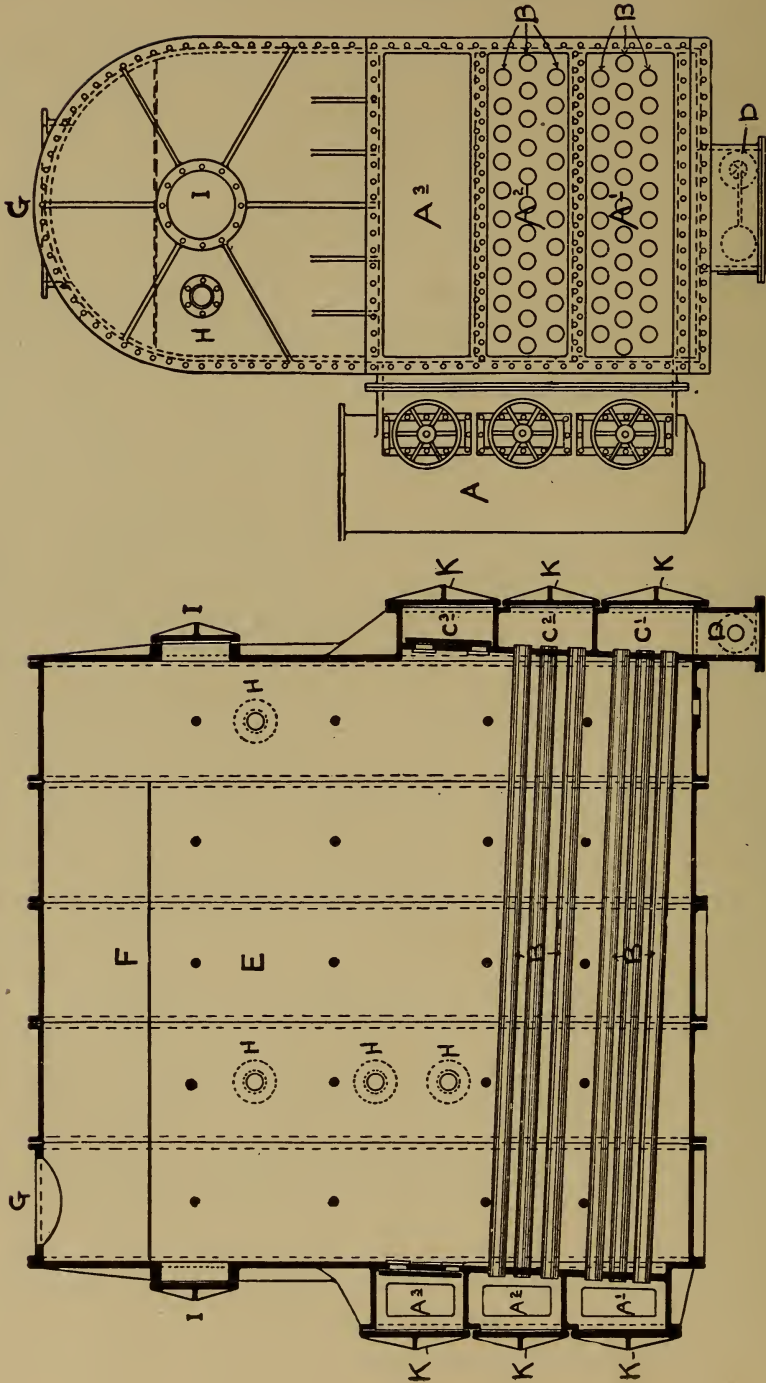

FIG. 289. Art. 593. — Newhall Evaporator.

wood extracts, caustic soda, alum, tannin, garbage products, glycerine, sugar of milk, pepsin, and licorice. In most cases, the multiple-effect apparatus is employed (Art. 594).

593. Newhall Evaporator. This is shown in Fig. 289. Steam is used to supply heat; it enters at *A*, and passes through the chambers *A*¹, *A*², to the tubes *B*, *B*. After passing through the tubes, it collects in the chambers *C*², *C*¹, from which it is drawn off by the trap *D*. The liquid to be distilled surrounds the tubes. The vapor forms in *E*, passes around the baffle plate *F* and out at *G*. The concentrated liquid is drawn off from the bottom of the machine.

594. Multiple-effect Evaporation. Conceive a second apparatus to be set alongside that just described; but instead of supplying

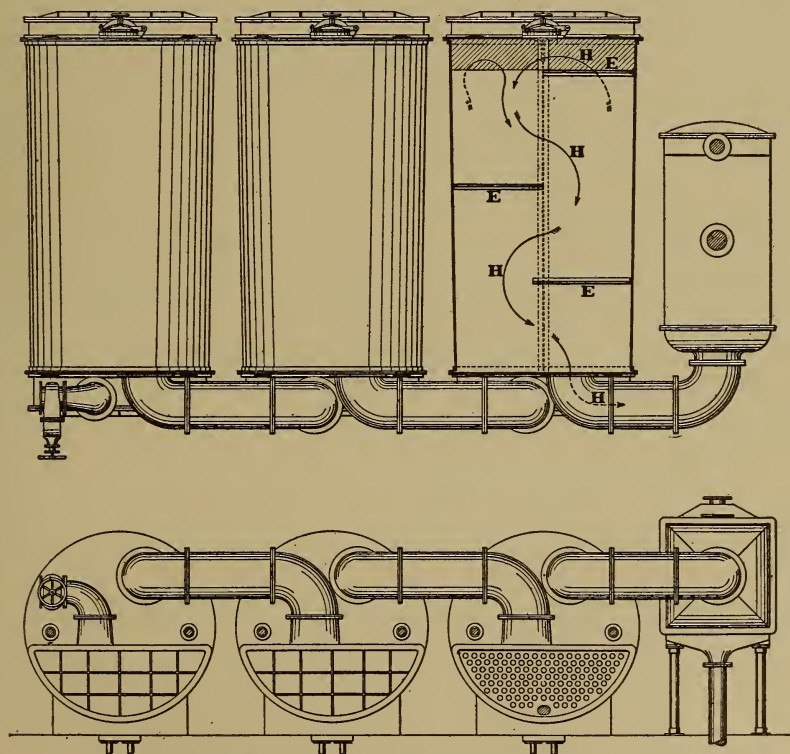

Fig. 290. Art. 595. — Triple Effect Evaporator.

steam at *A*, let the vapor emerging from *G* of the first stage be piped to *A* in the second, and let the liquid drawn off from the bot-

tom of the first be led into the second ; then further evaporation may proceed without the expenditure of additional heat, the liquid being partially evaporated and the vapor partially condensed by the interchange of heat in the second stage, *the pressure in the shell (outside the tubes) being less than that in the first stage*. The construction will be more clearly understood by reference to Fig. 290 (1a).

595. Yaryan Apparatus. Here the heat is applied *outside* the tubes, the liquid to be distilled being inside. The liquid is forced by a pump through a small orifice at the end of the tube, breaking into a fine spray during its passage. The fine subdivision and rapid movement of the liquid facilitate the transfer of heat. The baffle plates *E, E*, Fig. 291, serve to separate the liquid and its vapor, the former

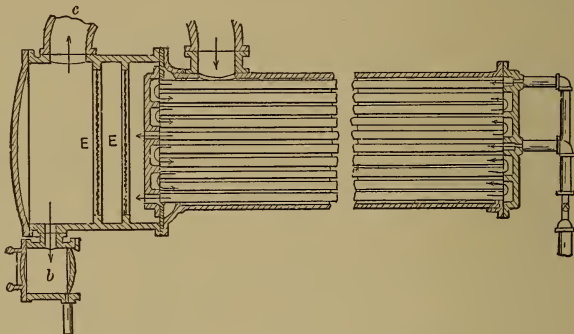

FIG. 291. Art. 595. — Yaryan Evaporator.

settling in the chamber *b*, the latter passing out at *c*. Figure 290 shows a “triple-effect” or three-stage evaporator; steam (preferably exhaust steam) enters the *shell* of the first stage. The liquor to be evaporated enters the *tubes* of this stage, becomes partly vaporized, and the separated vapor and liquid pass off as just described. From the outlet *c*, Fig. 291, the vapors pass through an ordinary separator, which removes any additional entrained liquid, discharging it back to *b*, and then proceed to the *shell* of the second stage. Meanwhile the liquid from the chamber *b* of the first stage has been pumped, through a hydrostatic tube which permits of a difference in pressure in two successive sets of tubes, into the *tubes* of the second stage. As many as six successive stages may be used;* the vapors from the last being drawn off by a condenser and vacuum pump. The liquid from the chamber *b* of the last stage is at maximum density.

596. Condition of Operation. The vapor condensed in the various shells is ordinarily water, which in concentrating operations may be

* The number of effects that can be used is limited by the difference in temperature of steam supplied and final condensate discharged.

drawn off and wasted, or, if the temperature is sufficiently high, employed in the power plant. The condenser is in communication with the last tubes, and, through them, with all of the shells and tubes excepting the first shell; but between the various stages we have the heads of liquid in the chambers b , which permit of carrying different pressures in the different stages. A gradually decreasing pressure and temperature are employed, from first to last stage; it is this which permits of the further boiling of a liquid already partly evaporated in a former effect. The pressure in the tubes of any stage is always less than that in the surrounding shell; the pressure in the shell of any stage is equal to that in the tubes of the previous stage.

597. Theory. Let W be the weight of dry steam supplied; the heat which it gives up is WL . Let w be the weight of liquid entering the first stage, H its heat, and h and l the heat of the liquid and latent heat corresponding to the pressure in the first-stage tubes. If x pounds of this liquid are evaporated in the first stage, the heat supplied is $xl + w(h - H)$, theoretically equal to WL ; whence

$$x = [WL - w(h - H)] \div l.$$

Then x pounds of vapor enter the shell of the second stage, giving up the heat xl . The weight of liquid entering the tubes of the second stage is $w - x$. Let the latent heat and heat of liquid at the pressure in the tubes of this stage be m and i : then the heat absorbed, if y pounds be evaporated, is $ym + (w - x)(i - h)$, the last term being negative, since i is less than h . Then

$$y = [xl - (w - x)(i - h)] \div m.$$

Consider now a third stage. The heat supplied may be taken at ym ; the heat utilized at

$$zM + (w - x - y)(I - i),$$

(z being the weight of liquid evaporated, M its latent heat, and I the corresponding heat of the liquid),

whence $z = [ym - (w - x - y)(I - i)] \div M$.

The analysis may be extended to any number of stages.

598. Rate of Evaporation. Ordinarily, the evaporated liquid is an aqueous solution; the total evaporation per pound of steam supplied increases with the number of stages, being practically limited by the additional constructive expense

and radiation loss. For a triple-effect evaporator, the total evaporation per W pounds of steam supplied is $x + y + z$. Let $W = 1$, and let the steam be supplied at atmospheric pressure, the vacuum at the condenser being 0.1 lb. absolute, and the successive shell pressures 14.7, 8.1, 1.5. The pressures in the *tubes* are then 8.1, 1.5, and 0.1: whence $L = 970.4$, $l = 987.9$, $h = 151.3$, $m = 1027.8$, $i = 81.9$, $I = 6.98$, $M = 1048.1$. Let H be 100, the liquid being supplied at 132° F. A definite relation must exist between w and W , in order that the supply of vapor to the last effect, y , may be sufficient to produce evaporation, yet not so great as to burden the apparatus; this is to be determined by the degree of concentration desired in any particular case, whence $x + y + z = (f)w$, in which (f) represents the proportion of liquid to be evaporated. Let $(f) = 1.0$, as is practically the case in the distillation of water; then $w = x + y + z$. We now have, $x = 0.982 - 0.0521w$, $y = 0.88 + 0.0211w$, $z = 0.726 + 0.094w$, $x + y + z = w = 2.588 + 0.063w$, whence $w = 2.76$. This is equivalent to about 27.6 lb. of water evaporated per pound of coal burned under the best conditions. By increasing the number of effects, evaporation rates up to 37 lb. have been attained in the triple-effect machine. A sextuple-effect apparatus has given an evaporation of 45 lb. of water per lb. of combustible in the coal.

599. Efficiency. The heat expended in evaporation is in this case $xl + ym + zM = 3080$ B. t. u. The heat supplied by the steam was $WL = 970.4$ B. t. u. The efficiency is, therefore, apparently 3.18, a result exceeding unity. A large amount of additional heat has, however, been furnished by the substance itself, which is delivered, not as a vapor, but as a liquid, at the condenser.

600. Water Supply. The condenser being supplied per pound of steam supplied to the first stage with v pounds of water, its heat increasing from n to N , the heat interchange is $zM = v(N - n)$, whence, $v = zM \div (N - n)$, the liquid being discharged at the boiling point corresponding to the pressure in the condenser. In this case, for $N - n = 25$, $v = 40.2$ lb., or the water supply is $40.2 \div 2.76 = 14.5$ lb. per pound of liquid evaporated. Some excess is allowed in practice: the greater the number of effects, the less, generally speaking, is the quantity of water required.

601. The Goss Evaporator. This is shown in Fig. 292. Steam enters the first stage F from the boiler G , say at 194 lb. pressure and 379° F. The liquid to be evaporated (water) here enters the *last* stage A , say at 62° F.; the boiling of the liquid in each successive stage from F to A produces steam which passes to the interior tube of the next succeeding stage, along with the water resulting from condensation in the interior tube of the previous stage. The condensed steam from the first stage, is, however, returned to the boiler, which thus operates like a house-heating boiler, with closed circulation. Let 1 lb. of liquid be evaporated in F ; its pressure and temperature are so adjusted that, in this case, the whole temperature range between that of the steam (379° F.) and that of the liquid finally discharged from A (213° F.) is equally divided between the stages. The

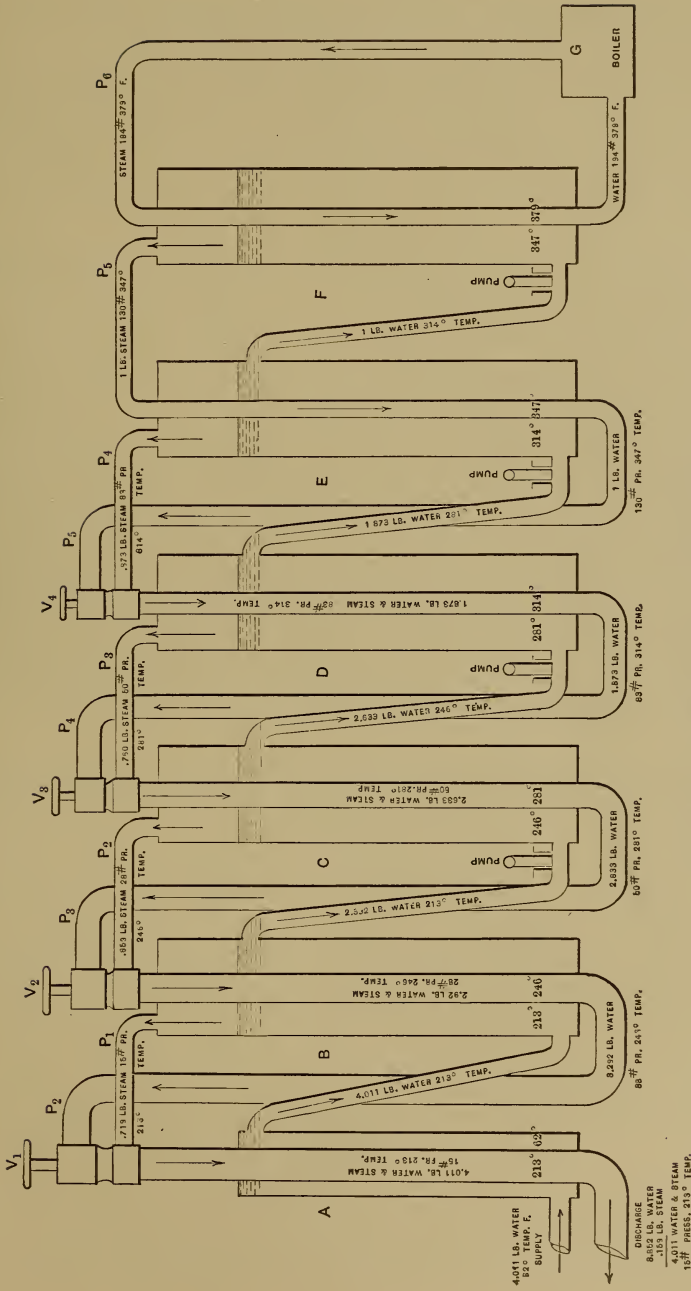

FIG. 292. Art. 601, Prob. 3. — Goss Evaporator.

amount of vapor produced in any stage may then be computed from the heat supplied for the assigned temperature and corresponding pressure. Finally, in *A*, no evaporation occurs, the incoming liquid being merely heated; and it is found that the weights of discharged liquid and incoming liquid are equal, amounting each to 4.011 lb. The steam supplied by the boiler may be computed; in *F*, we condense steam at 379° F., at which its latent heat per pound is 845.8. *It is assumed that 3 per cent of the heat supplied in each effect is lost by evaporation*; the available heat in each pound of steam supplied is then $0.97 \times 845.8 = 820.426$. This heat is expended in evaporating 1 lb. of water at 312.6° to dry steam at 345.8°, requiring $1187.44 - 282.26 = 905.18$ B. t. u., for which $\frac{905.18}{820.43} = 1.1$ lb. of steam are required. The whole evaporation for the six-effect apparatus is $\frac{4.011}{1.1} =$

3.646 lb. per pound of steam. For the second effect, *E*, the heat supplied is $L_{345.8} = 870.66$, gross, or $0.97 \times 870.66 = 844.54$, net. The heat utilized is $1.873(282.22 - 248.7) + (0.873 \times 895.18) = 844.54$. In *D*, the heat supplied is $0.97[(0.873 \times L_{312.6}) + 1(316.98 - 282.22)] = 790.8$; that utilized is $2.633(248.7 - 215.3) + (0.76 \times 918.42) = 790.8$. The heat interchange is perfect; it should be noted that the liquid to be evaporated and the heating medium are moving in *opposite* directions. This involves the use of a greater amount of heating surface, but leads to higher efficiency, than the customary arrangement. An estimated economy of 60 lb. of water per pound of coal is possible with seven stages (1).

The Petleton evaporator, instead of reducing the pressure over the liquid to permit of easier vaporization, mechanically *compressed* the vapor previously removed and thus enabled it to further vaporize the remaining liquid. Steam was used to start the apparatus. The vapor generated was compressed by a separate pump to a higher pressure and temperature and was then passed back through a coil in contact with the residual liquid. Here it gave up its heat and was condensed and trapped off. Enough additional vapor was thus produced to maintain operation without the further supply of steam. With an efficient pump, the fuel consumption may be less than half that ordinarily reached in triple effect machines.

FUSION

602. Change of Volume during Change of State. The formula

$$V - v = \frac{778 L dT}{T dP}$$

was derived in Art. 368. The specific volume of a vapor below the critical temperature exceeds that of the liquid from which it is produced;

consequently $V - v$ has in all cases a positive value, and hence $\frac{dT}{dP}$ must be positive; *i.e.* increase of pressure causes an increase in temperature. It is universally true that the boiling points of substances are increased by increase of pressure, and *vice versa*, at points below the critical temperature. If for any vapor we know a series of corresponding values of V , L , T , and v , we may at once find the rate of variation of temperature with pressure.

603. Fusion. The same expression holds for the change of state described as fusion; the Carnot cycle, Figs. 162, 163, may represent melting along ab , adiabatic expansion of the liquid along bc , solidification along cd , and adiabatic compression of the solid to its melting point along da . In this case, V does not always exceed v ; it does for the majority of substances, like wax, spermaceti, sulphur, stearine, and paraffin, which contract in freezing; and for these, we may expect to find the melting point raised by the application of pressure. This has, in fact, been found to be the case in the experiments of Bunsen and Hopkins (2). On the other hand, those few substances, like ice, cast iron, and bismuth, which expand in freezing, should have their melting points lowered by pressure; a result experimentally obtained, for ice, by Kelvin (3) and Mousson (4). The melting point of ice is lowered about 0.0135° F, for each atmosphere of pressure. The expansion of ice in freezing is of practical consequence. A familiar illustration is afforded by the bursting of water pipes in winter.

604. Comments. As the result of a number of experiments with non-metallic substances, Person (5) found the following empirical formula to hold:

$$L = (C - c)(T + 256),$$

in which L is the latent heat of fusion, C , c are the specific heats in the liquid and solid states respectively, and T the Fahrenheit temperature of fusion. Another general formula is given for *metals*. A body may be reduced from the solid to the liquid state by *solution*. This operation is equivalent to that of fusion, but may occur over a wider range of temperatures, and is accompanied by the absorption of a different quantity of heat. The applications of the fundamental formulas of thermodynamics to the phenomena of solution have been shown by Kirchoff (6). The **temperature of fusion** is that highest temperature at which the substance can exist in the solid state, under normal pressure. The latent heat of fusion of ice has a phenomenally high value.

LIQUEFACTION OF GASES

605. Graphical Representation. In Fig. 293, let a represent the state of a superheated vapor. It may be reduced to saturation, and liquefied, either at constant pressure, along acd , the temperature being reduced, or at constant temperature along abe , the pressure being increased. After reaching the state of saturation, any diminution of volume at constant temperature, or any decrease in temperature at constant volume, must produce partial liquefaction. Constant temperature liquefaction is not applicable to gases having low critical temperatures. Thus, in

FIG. 293. Art. 605.—Liquefaction of Superheated Vapor.

Fig. 294, ab is the liquid line and cd the saturation curve of carbon dioxide, the two meeting at the critical temperature of 88° F. From the state e this substance can be liquefied only by a reduction in temperature. With "permanent" gases, having critical temperatures as low as -200° C., an extreme reduction of temperature must be effected before pressure can cause liquefaction.

606. Early Experiments. Monge and Clouet, prior to 1800, had liquefied sulphur dioxide, and Northmore, in 1805, produced liquid chlorine and possibly also sulphurous acid, in the same manner as was adopted by Faraday, about 1823, in liquefying chlorine, hydrogen sulphide, carbon dioxide, nitrous oxide, cyanogen, ammonia, and hydrochloric acid gas. The apparatus consisted simply of a closed tube, one end of which was heated, while the other was plunged in a freezing mixture. Pressures as high as 50 atmospheres were reached. Colladon supplemented this apparatus with an expansion cock, the sudden fall of pressure through the cock cooling the gas; and in Cailletet's hands this apparatus led to useful results. Thilorier, utilizing the cooling produced by the evaporation of liquid carbon dioxide, first produced that substance in the solid form. Natterer compressed oxygen to 4000 atmospheres, making its density greater than that of the liquid, but without liquefying it. Faraday obtained minimum temperatures of -166° F. by the use of solid carbon dioxide and ether in vacuo.

607. Liquefaction by Cooling. Andrews, in 1849, recognizing the limiting critical temperature, proposed to liquefy the more permanent

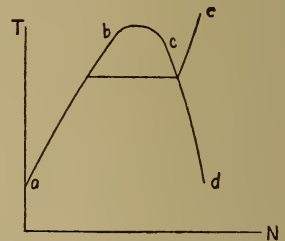
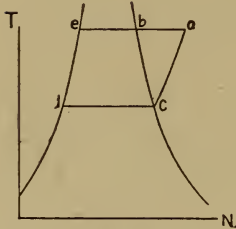

FIG. 294. Art. 605.—Liquefaction and Critical Temperature.

gases by combining pressure and cooling. Figure 295 shows the principle involved. Let the gas be compressed isothermally from P to a , expanded through an orifice along ab , re-compressed to c , again expanded to d , etc. A single cycle might suffice with carbon dioxide, while many successive compressions and expansions would be needed with a more permanent gas. The process continues, in all cases, until the temperature falls below the critical point; and at x the substance begins to liquefy. The action depends upon the cooling resulting from unrestricted expansion. With an absolutely perfect gas, no cooling would occur; the lines ab , cd , etc., would be horizontal, and this method of liquefaction could not be applied. The "perfect gas," in point of fact, could not be liquefied. All common gases have been liquefied.

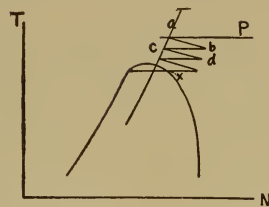

FIG. 295. Art. 607. — Liquefaction by Pressure and Cooling.

608. Modern Apparatus. Cailletet and Pictet, independently, in 1877, succeeded in liquefying oxygen. The Pictet apparatus is shown in Fig. 296. The jacket a was filled with liquid sulphur dioxide, from which the vapor was drawn off by a pump, and delivered to the condenser b .

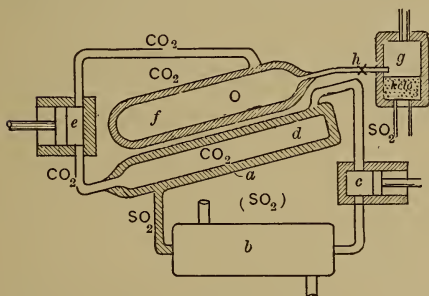

FIG. 296. Art. 608, Prob. 7. — Cascade System.

liquid oxygen. The series of cooling agents used suggested the name **cascade system**.

609. Dewar's Experiments. Dewar liquefied air in 1884 and nitrogen about 1892. In 1895 he solidified air by free expansion, producing a jellylike substance. In 1896 he obtained liquid hydrogen, by the use of which air and oxygen were solidified, forming white masses. A temperature of -396.4° F. was obtained. Dewar's final apparatus was that of Pictet, but compressors were used to deliver

The compressor c re-delivered this substance in the liquid condition to the jacket, cooling in a a quantity of carbon dioxide which was itself compressed in e and used as a cooling jacket for the oxygen gas in f . The oxygen was formed in the bomb g , and expanded through the cock h , producing a fall of temperature which, supplemented by the cooling effect of the carbon dioxide, produced

the gases to the liquefying chamber, and ethylene was employed in place of carbon dioxide.

610. Regenerative Process ; Liquid Air. The fall of temperature accompanying a reduction in pressure has been utilized by Linde (7) and others in the manufacture of liquid air. In the first form of apparatus, shown in Fig. 297, air was compressed to about 2000 lb. pressure in a three-stage machine *A*, and after cooling in *B* was delivered to the inner tube of a double coil *C*, through which it passed to the expansion valve *D*. Here a considerable fall of temperature took place. The cooled and expanded air then passed back through the outer tube of the coil, cooling the air descending the inner tube, and was discharged at *F*. The effect was cumulative, and after a time liquid air was deposited in *E*. In the present type of machine, the compressor takes its supply from *F*, a decided improvement. The regenerative principle has been adopted in the recent forms of apparatus of Hampson, Solvay, Dewar, and Tripler.

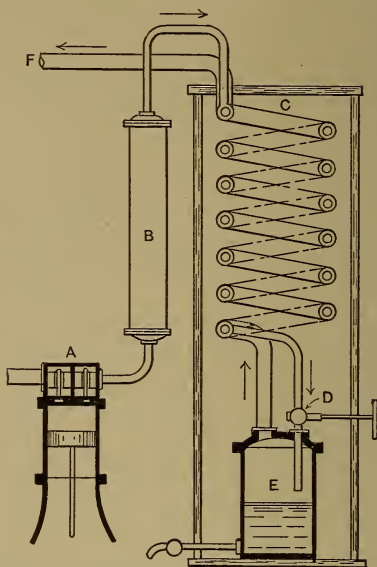

FIG. 297. Art. 610.—Liquefaction of Air.

The latent heat of evaporation of air at atmospheric pressure is about 140 B. t. u. (8). In its commercial form, it contains small particles of solid carbon dioxide; when these are removed by filtration, the liquid becomes clear. The boiling point of nitrogen is somewhat higher than that of oxygen; fairly pure liquid oxygen may, therefore, be obtained by allowing liquid air to partially evaporate (9). The cost of production of liquid air has been carefully estimated in one instance to approach 22 cents per pint (10).

(1) *Trans. A. S. M. E.*, XXV, 03. The steam table used was Peabody's, 1890 ed. The temperatures noted on Fig. 292 are approximate: those in the text are correct. (1 a) See the paper by Newhall, before the Louisiana Sugar Planters' Association, June 13, 1907. (2) *Rep. B. A.*, 1854, II, 56. (3) *Phil. Mag.*, 1850: III, xxxvii, 123. (4) Deschanel, *Natural Philosophy* (Everett tr.), 1893, II, 331. (5) *Ann. de Chem. et de Phys.*, November, 1849. (6) *Pogg. Ann.*, 1858. (7) Zeuner, *Technical Thermodynamics* (Klein), II, 303-313; *Trans. A. S. M. E.*, XXI, 156. (8) Jacobus and Dickerson: *Trans. A. S. M. E.*, XXI, 166. (9) See the very complete paper by Rice, *Trans. A. S. M. E.*, XXI, 156. (10) *Tests of a Liquid Air Plant*, Hudson and Garland; *University of Illinois Bulletin*, V, 16.

SYNOPSIS OF CHAPTER XVII

Distillation

The *still* is a device for purifying liquids or recovering solids by partial evaporation.

By *evaporation in vacuo*, the heat consumed may be reduced in many important applications: waste heat may be employed.

Steam may supply the heat; in the *Newhall* apparatus, the steam circulates through tubes.

In the *Yaryan* apparatus, the steam surrounds the tubes.

The vapors rising from the solution may supply the heat required in a *second* "effect," provided that the solution there is under a less pressure than in the first stage.

As many as six stages are used, the pressure on the solution decreasing step by step.

Evaporation per effect: $x = \frac{WL - w(h - H)}{l}$; $y = \frac{xI - (w - x)(i - h)}{m}$;

$$z = \frac{ym - (w - x - y)(I - i)}{M}$$

In a typical case, the triple-effect machine gives an evaporation of 2.76 lb. per pound of steam.

Water required at the condenser per pound of liquid evaporated = $\frac{zM}{(N - n)}$.

In the *Goss evaporator*, the steam and the solution move in opposite directions; this increases the necessary amount of surface, but also the efficiency. *Petleton* evaporator.

Fusion

The formula $V - v = \frac{778 L}{T} \frac{dT}{dP}$ applies to *fusion*. The *melting points* of substances may be either *raised* or *lowered* by the application of pressure, according as the *specific volume* in the *liquid* state is *greater* or *less* than that in the *solid* state.

The *melting point of ice* is lowered about 0.0135° F. per atmosphere of pressure imposed. $L = (C - c)(T + 256)$ for non-metallic substances.

Liquefaction of Gases

A *vapor* below the critical temperature may be liquefied either at *constant pressure* or at *constant temperature*.

No substance can be liquefied unless below the critical temperature.

A few common substances have been liquefied by the use of *pressure* and *freezing mixtures*.

A further lowering of temperature is produced by *free expansion*.

Liquefaction may be accomplished with actual gases by *successive compressions* and *free expansions*.

The *Pictet* apparatus (*cascade system*) employed the latent heat of vaporization of successive fluids to cool more volatile fluids.

The *regenerative system* provides for the free expansion of a highly compressed gas previously reduced to atmospheric temperature. This is used in manufacturing *liquid air*.

PROBLEMS

1. Water entering a still at 40° F. is evaporated, (a) at atmospheric pressure, (b) at 2 lb. absolute pressure. What is the saving in heat in the latter case? What more important saving is possible?

2. Water entering a double-effect evaporator at 80° F. is completely distilled, the steam supplied being dry and at atmospheric pressure, the pressure in the second-stage shell being 8 lb. and that in the second-stage tubes 1 lb. Cooling water is available at 60° F. The temperature of the circulating water at the condenser outlet is 80° . Find the steam consumption per pound of water evaporated and the cooling water consumption, if the vacuum pump discharge is at 85° F.

3. In Fig. 292, take temperatures as given; assume one pound of water to be completely evaporated in F , and complete condensation to occur in the inner tube of each effect; and compute, allowing 3 per cent for radiation, as in Art. 601:

(a) The weight of steam condensed in F .

(b) The weight of steam evaporated in E , and of water delivered to E .

(c) The weight of boiler steam used per pound of water evaporated in the whole apparatus. Use the steam tables on pp. 247, 248.

4. The weight of one cubic foot of H_2O at 32° F. and atmospheric pressure being 57.5 lb. as ice and 62.42 lb. as water, and the latent heat of fusion of ice being 142 B. t. u., find how much the melting point of ice will be lowered if the pressure is doubled (Art. 603).

5. The specific heat of ice being 0.504, find its latent heat of fusion at 32° F. from Art. 604.

6. How much liquid air at atmospheric pressure would be evaporated in freezing 1 lb. of water initially at 60° F.?

7. In a Pictet apparatus, Fig. 296, 1 lb. of air is liquefied at atmospheric pressure, free expansion having previously reduced its temperature to the point of liquefaction. The condensation is produced by carbon dioxide, which evaporates in the jacket without change of temperature, at such a pressure that its latent heat of vaporization is 200 B. t. u. How many pounds of carbon dioxide are evaporated? This dioxide is subsequently liquefied, at a higher pressure and while dry (latent heat = 120), and cooled through 100° F. Its specific heat as a liquid may be taken as 0.4. The liquefaction and cooling of the carbon dioxide are produced by the evaporation of sulphur dioxide (latent heat 220 B. t. u.). What weight of sulphur dioxide will be evaporated per pound of air liquefied? Why would the operation described be impracticable?

8. From Art. 245, find the fall of temperature at expansion in a Linde air machine in which the air is compressed to 2000 lb. absolute and cooled to 60° F., and then expanded to atmospheric pressure. How many complete circuits must the air make in order that the temperature may fall from 60° F. to -305° F., if the same fall of temperature is attained at each circuit?

9. Plot on the entropy diagram the path of ice heated at constant pressure from -400° F. to 32° F., assuming the specific heat to be constant, and then melted at atmospheric pressure. How will the diagram be changed if melting occurs at a pressure of 1000 atmospheres?

Plot a curve embracing states of the completely melted ice for a wide range of pressures. Construct lines analogous to the constant dryness lines of the steam entropy diagram and explain their significance.

10. At what temperature will the latent heat of fusion of ice be 0? What would be the corresponding pressure?

CHAPTER XVIII

MECHANICAL REFRIGERATION

611. History. Refrigeration by "freezing mixtures" has been practiced for centuries. Patents covering *mechanical refrigeration* date back at least to 1835 (1). In the first machines, ether was the working substance, and the cost of operation was high. Pictet introduced the use of sulphur dioxide and carbon dioxide. The transportation of refrigerated meats began about 1873 and developed rapidly after 1880, most of the earlier machines using air as a working fluid. The possibility of safely shipping refrigerated fresh fruits, milk, butter, etc., has revolutionized the distribution of these food products; and, to a large extent, refrigerating processes have eliminated the use of ice in breweries, packing houses, fish and meat markets, hotels, etc. The two important applications of artificial refrigeration at present are for the production of artificial ice and for cold storage.

612. Carnot Cycle Reversed. In Fig. 298, let the cycle be worked in a counter-clockwise direction. Heat is absorbed along dc and emitted along ba ; the latter quantity of heat exceeds the former by the work expended, $abcd$. The object of refrigeration is to *cool* some body. This cooling may be produced by a flow of

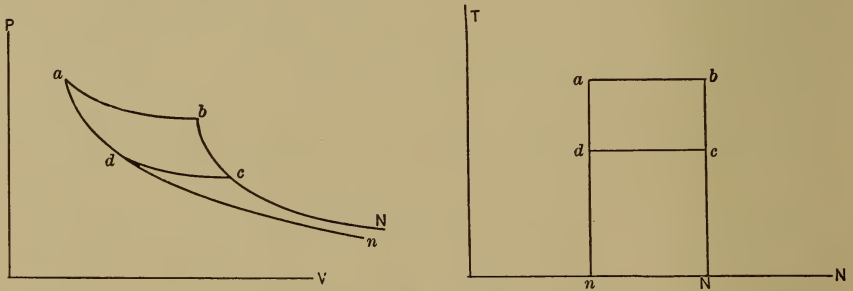

FIG. 298. Art. 612.—Reversed Carnot Cycle.

heat from the body to the working fluid along dc . Cyclic action is possible only under the condition that the working fluid afterward transfer the heat to some second body along ba . The body to be

cooled is called the *vaporizer*; the second body, which in turn receives heat from the working fluid, is the *cooler*. The heat taken from the vaporizer is $ndcN$; that discharged to the cooler is $nabN$. The function of the machine is to cause heat to pass from the vaporizer to a substance *warmer than itself*; *i.e.* the cooler. This is accomplished without contravention of the second law of thermodynamics, by reason of the expenditure of mechanical work. The refrigerating machine is thus a *heat pump*.

The Carnot cycle, with a gas as the working fluid, would lead to an excessively bulky machine (Art. 249). Early forms of apparatus therefore embodied the *regenerative* principle (Art. 257). This is illustrated in Fig. 299.

Without the regenerator, air would be compressed adiabatically from 1 to 2, cooled at constant pressure along 2 3, expanded adiabatically along 3 4, and allowed to take up heat from the body to be refrigerated along 4 1. In practice, this heat is partly taken from the body, and partly from other surrounding objects after the working air has left this body, say at 5. The

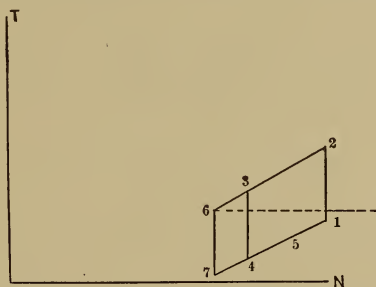

FIG. 299. Art. 612. — Regenerative Refrigeration.

absorption of heat along 5 1 then effects no good purpose. If, however, this part of the heat be absorbed from the compressed air at 3, that body of air may be cooled, in consequence, along 3 6, so that adiabatic expansion will reduce the temperature to that at 7, lower than that at 4. This is accomplished by causing the air leaving the cooler to come into transmissive contact with that leaving the vaporizer. The effect of the regenerator is cumulative, increasing the fall of temperature at each step; but since the expansion cylinder must be kept constantly colder as expansion proceeds, a limit soon arises in practice.

In Kirk's machine (1863), a compressing cylinder was used for the operation *cb*, Fig. 298, and two expansive cylinders for the operation *ad*, one receiving the air from each end of the compressor cylinder. The pressure throughout the cycle was kept considerably above that of the atmosphere, and temperatures of -39° F. were obtained. The regenerator consisted of layers of wire gauze located in the pistons (2). The air machines of Hargreaves and Inglis (1878), Tuttle and Lugo, Lugo and McPherson, Hick Hargreaves, Stevenson, Haslam, Lightfoot, Hall, and Cole and Allen, have been described by Wallis-Taylor (3). The Bell-Coleman machine may be regarded as the forerunner of all of these, although many variations in construction and method of working have been introduced.

613. Bell-Coleman Machine. This is the Joule air engine of Art. 101, reversed. It operates in the net cycle given by an air compressor and an air engine, as in Art. 213. In Figs. 300 and 301, *C* is the room to be cooled, *A* a cooler, *M* a compressor, and *N* an expansive cylinder (air engine). In the position shown, with the pistons moving toward the left, air flows from *C* to *M* at the temperature T_c . On the return stroke, the valve *a* closes, the air is compressed along *cb*, Fig. 301, and the valve *s*

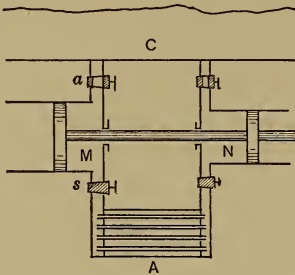

FIG. 300. Art. 613. — Bell-Coleman Machine.

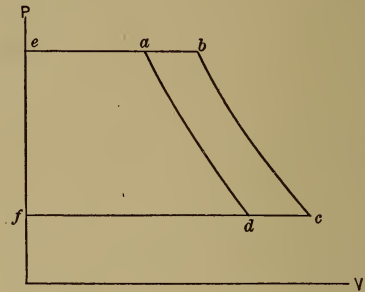

FIG. 301. Arts. 613, 614, 616, 622, 623. — Reversed Joule Cycle.

opens, permitting of discharge into *A* along *be*, at the temperature T_b . The operation is now repeated, the drawing in of air from *C* to *M* being represented by the line *fc*. Meanwhile an equal weight of air has been passing from *A* to *N* at the temperature T_a , less than T_b on account of the action of the cooler, along *ea*; expanding to the pressure in *C* along *ad*, reaching the temperature T_a , lower than that in *C*; and passing into *C* at constant pressure along *df*. The work expended in the compressor cylinder is *febe*; that done by the expansion cylinder is *fead*; the difference, *abcd*, represents work *required from without* to permit of the cyclic operation. If the lines *ad*, *bc*, are isothermals,

$$\frac{T_b}{T_c} = \frac{T_a}{T_d}$$

Suitable means are provided for cooling the air in the compressor cylinder, so as to avoid the losses due to a rise of temperature (Art. 195), and also for drying the air entering the expansion cylinder.

The expansion cylinder is necessary for the operation. Free expansion of the air through a valve from p_e to p_f would be unaccompanied by any drop in temperature.

614. Analysis of Action. Let air at 147 lb. pressure and 60° F., at *a*, Fig. 301, expand adiabatically behind a piston along *ad*, until its pressure is 14.7 lb. Its temperature at *d* is

$$T_d = T_a \div \left(\frac{P_a}{P_d}\right)^{\frac{\gamma-1}{\gamma}} = 519.6 \div (10)^{0.2875} = 269^\circ \text{ absolute or } -191^\circ \text{ F.}$$

Let this cold air absorb heat along dc at constant pressure, until its temperature rises to 0° F. Then let it be compressed adiabatically until its pressure is again 147 lb., along cb . Since

$$\frac{T_a}{T_d} = \frac{T_b}{T_c}, T_b = 459.6 \left(\frac{519.6}{269} \right) = 890^\circ \text{ absolute, or } 430^\circ \text{ F.}$$

The air now rejects heat at constant pressure along ba to cold water, or some other suitable agent, and the action recommences. In practice, the paths ad and bc are very nearly adiabatic, but if $n < \gamma$, the changes of temperature are less than those just computed.

615. Entropy Diagram. Let $aenfbc$, Fig. 302, represent the pv and nt diagrams of a Bell-Coleman machine working in two compressive stages. Choosing the point c on the entropy plane arbitrarily as to entropy, but in its proper vertical location, we plot the line of constant pressure ca up to the line of temperature at a . Then ae is drawn as an adiabetic, intersected

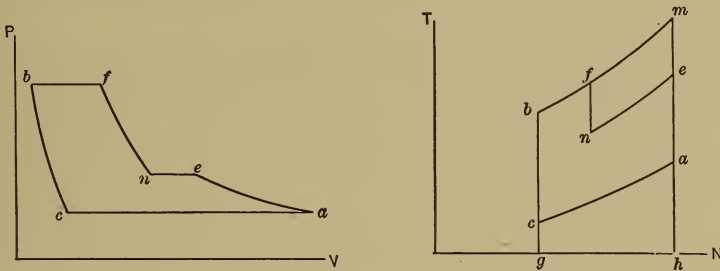

Fig. 302. Art. 615.— Two-stage Joule Cycle.

by the constant pressure curve ne , with nf , cb , and bf as the remaining paths. The area $aenfbc$ measures the expenditure of work to effect the process. Along ca , theoretically, heat is taken from the cold chamber to the extent $cgha$. The work expended in single-stage compression would have been $camb$. We have then the following ratios of heat extracted to work expended:

$$\text{single-stage compression, } \frac{cgha}{camb}; \text{ two-stage compression, } \frac{cgha}{aenfbc}.$$

616. Work of Compression. In Fig. 301, for M pounds of air circulated per minute, the heat withdrawn from the cold chamber along dc is $Q = Mk(T_c - T_d)$. The work expended in compression is

$$\begin{aligned} W_c &= M \left(P_b V_b + \frac{P_b V_b - P_c V_c}{n-1} - P_c V_c \right) = \frac{Mn}{n-1} (P_b V_b - P_c V_c) \\ &= \frac{Mn}{n-1} \left(P_b^{\frac{n-1}{n}} P_c^{\frac{1}{n}} V_c - P_c V_c \right) = \frac{Mn P_b V_b}{n-1} \left[\left(\frac{P_b}{P_c} \right)^{\frac{n-1}{n}} - 1 \right]. \end{aligned}$$

If compression is **adiabatic**, $n = \gamma$, $\left(\frac{P_b}{P_c}\right)^{\frac{n-1}{n}} = \frac{T_b}{T_c}$, $P_c V_c = R T_c$, $R = k \left(\frac{\gamma - 1}{\gamma}\right)$, and $W_c = M k T_c \left(\frac{T_b}{T_c} - 1\right) = M k (T_b - T_c)$. Similarly, for the engine (clearance being ignored in both cases), $W_E = M k (T_a - T_d)$. The net work expended is then

$$W_c - W_E = M k (T_b - T_c - T_a + T_d).$$

We might also write, heat delivered to the cooler $= q = M k (T_b - T_a)$,

$$W_c - W_E = q - Q = M k (T_b - T_a - T_c + T_d).$$

Practical imperfections will increase the power consumption 30 to 50 per cent above this.

617. Cooling Water. The heat carried away at the cooler must be equal to the heat extracted along dc plus the heat equivalent of the net work expended; it is

$$M k (T_c - T_d + T_b - T_c - T_a + T_d) = M k (T_b - T_a),$$

as the path indicates. Let the rise in temperature of the cooling water be $T - t$: then the weight of water required is $M k (T_b - T_a) \div (T - t)$.

618. Size of Cylinders. At N revolutions per M pounds of air circulated, the displacement per stroke of the double-acting compressor piston must be, ignoring clearance, $D = M V_c \div 2 N = \frac{M R T_c}{2 N P_c}$.

The same air must pass through the expansion cylinder; its displacement is $\frac{M R T_d}{2 N P_d}$; the two displacements have the ratio $\frac{T_c}{T_d}$ if the cylinders run at equal r. p. m.

The piston displacements may be corrected for clearance as in Art. 233. They should be further increased from 5 to 10 per cent to allow for imperfect valve action, etc. A slight drop in pressure at the end of expansion is not objectionable. The temperature T_d and the capacity of the machine may be varied by changing the point of cut-off of the expansion cylinder.

619. Practical Proportions. In air machines of the so-called "open type," the pressure in the cold chamber is that of the atmosphere; the temperature may be anywhere between 0 and 50° F. The maximum pressure is often made four atmospheres absolute. The cooling water may be warmed from 60 to 80° F., and the air may leave the condenser at 90° F. Clearance may be from 2 per cent upward; piston speeds range from 75 to 300 ft. per minute, according to the type of compressor.

620. Objections to Air Machines. The size of apparatus is inordinate as compared with that of the vapor-compression machines to be described. The size may

be considerably reduced by operating under pressure, as in the Kirk and Allen "dense air" machines, in which the suction pressure exceeds that of the atmosphere. Small machines of the latter type are frequently used in marine service for cooling pantries and for making ice for table use. The suction pressure is about 65 lb., the discharge pressure 225 lb. Coils must be used in the vaporizer. The regenerative modification (Art. 612) may be applied, resulting in temperatures as low as -80° F. Much difficulty has been experienced in open air machines from the presence of water vapor, which congeals in the pipes and passages at low temperatures. This objection is avoided by working on the "dense air" principle. Light-foot (4) has introduced a form in which *expansion* is conducted in two stages. The temperature of the air in the first stage is reduced to only about 35° F., at which most of the vapor is precipitated and carried off, before the air enters the second cylinder. In many air machines, ordinary mechanical separators are used to dry the air.

621. Coefficient of Performance. In all cases, we have the relation *heat taken from the cold body + work done = heat rejected to the cooler*; or $Q + W = q$. The ratio $Q \div W$ is described as the **coefficient of performance**. For the Carnot cycle, it is obviously $t \div (T - t)$, the limiting values being unity and infinity. This ratio is sometimes spoken of as the **efficiency**, a designation sufficiently correct so far as work expenditure goes, but which is apparently not in conformity with the principle that no physical transformation can have an efficiency equalling unity. Figure 302 *b* explains the anomaly. The Carnot cycle is *abcd*; *an* and *bN* are indefinite adiabatics. Now $ndcN \div abcd = Q \div W$ may have any value whatever exceeding 1; but these two areas do not represent all of the heat actions occurring in the cycle. Heat has been removed by the condenser along *ba*, equivalent to $nabN = q$. We may indefinitely lower the "efficiency" by increasing the upper temperature, as by the paths *ef*, *gh*, etc., without at all increasing the useful refrigerating effect obtained. We may, in fact, regard refrigeration as a *negative effect produced by the cooling in the condenser*, the negative work done being regarded as a by-product of this cause: $-q = -Q - W$. A reversal of the argument of Art. 139 serves to show that no cycle can give a higher coefficient of performance than that of Carnot.

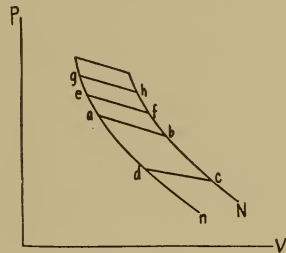

FIG. 302 *b*. Art. 621.—Coefficient of Performance.

622. Desirable Range. The value of the coefficient of performance is increased as that of $(T - t)$ decreases; *i.e., for efficient refrigeration, the range of temperature must be small*, a result of extreme practical importance. It is more economical to cool the given body of air or other substance directly through the required range of temperature, than to cool

one tenth, say, of this body, through ten times the temperature range, afterward cooling the remainder by mixture. This is a special example of the general thermodynamic principle that mixtures of substances at different temperatures are wasteful, such processes being irreversible. In practice, T is fixed by the temperature of the cooling water. It is seldom less than 60° F. The refrigerant temperature t should then be kept as high as possible, for the service in question, if operation is to be efficient; it must, however, be somewhat below the desired room or solution temperature, in order that the heat transfer may be reasonably rapid. In making ice, for example, t must be considerably below 32° F.

A reversal of the demonstration in Art. 255, as applied to Fig. 301, shows that the coefficient of performance for the Joule cycle (Bell-Coleman machine), with adiabatic paths, is $\frac{T_a}{T_a - T_d} = \frac{T_c}{T_b - T_c}$; for the corresponding Carnot cycle it would have been $T_c \div (T_a - T_c)$, a naturally higher value.*

Since any heat motor using air is bulky, it is necessary, in order to keep the size of these machines within reasonable limits, to make the temperature range large. This lowers the coefficient of performance, which in practice is usually only about one fifth that of a good ammonia refrigerating machine. Air, however, is the least expensive of fluids, is everywhere obtainable, is safe, and may be worked at high temperatures without excessive pressure.

623. The Kelvin Warming Machine. In Fig. 301, let an air engine receive its supply along ea at normal temperature and high pressure. The air expands along ad , falling in temperature, after which it is warmed by transmission from the external atmosphere along dc and compressed in a separate cylinder along cb . The temperature at c is equal to that at a . The compression along cb increases the temperature, and the hot air may be discharged into coils in an apartment to be heated. The ratio of heating done to power expended is

$$\frac{T_b \cdot T_a}{T_b - T_a - T_c + T_d} = \frac{T_a}{T_a - T_d}$$

The entropy diagram is that of Fig. 302, and the ratio of heat delivered to the room to work expended is here $bmhg \div bmac$, which exceeds unity, because of the heat supplied by the external air. This is consequently an ideal method for heating. Its advantage increases as the range of temperature decreases. Considering an ideal heat engine and an ideal warming machine, both working in the same Carnot cycle, the combined efficiency so far as power is concerned would be unity. The efficiency would exceed that of direct stove heating without any loss whatever, whenever the range of temperature in the engine exceeded that in the warming machine. Practically, the economical range of temperature would be low, the machine of immense size, and the operation slow.

* T_c is the highest temperature at which refrigeration may be performed; and T_a is the lowest temperature at which the cooling water is effective.

624. The Vapor Compression Machine. In the air machine, the temperature is reduced by expansion in a working cylinder. The mere flow of the air through a valve would not perceptibly lower its temperature (Art. 73). With a *vapor*, a decided lowering of temperature occurs when the pressure is reduced by free expansion. The expansion cylinder may, therefore, be omitted, and this omission is made in spite of the fact that an opportunity for saving some power is thereby lost.

625. Principle. If a small quantity of ether be poured into the palm of the hand, a sensation of cold is produced. This is due to the rapid evaporation of the ether at the temperature of the body; the heat thus absorbed by the ether is received from the hand, decreasing the temperature of the latter. In Fig. 303, let the closed

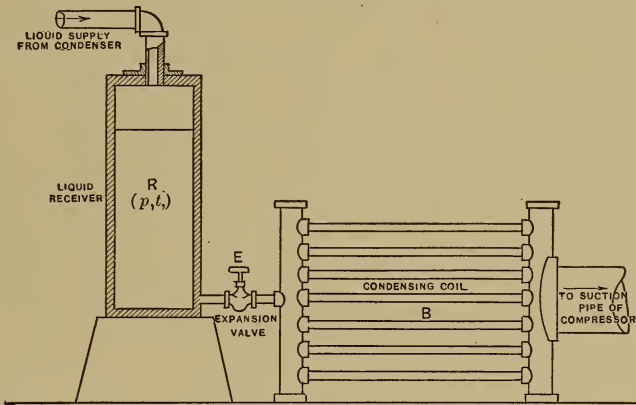

FIG. 303. Art. 625. — Vapor Refrigeration.

vessel R be partly filled with a liquid at the temperature t , having above it its saturated vapor. Then the pressure in R will be that at which the boiling point of the liquid is t . If the liquid is anhydrous ammonia, for example, and $t = 68^\circ \text{ F.}$, $p = 125.056 \text{ lb. absolute.}$ Let some of the liquid pass through E to the condensing coil B , in which the pressure is P , less than p . Its heat per pound tends to change from h to H ; since h exceeds H , a certain amount of liquid must be evaporated in B to reestablish thermal equilibrium; thus,

$$h = H + XL, \text{ or } X = \frac{h - H}{L}.$$

If, now, the coil B be immersed in water at a temperature higher than its own, the remaining $(1 - X)$ pounds of liquid may evapo-

rate; the surrounding water will be cooled, giving up heat $(1 - X)L$ if the substance in the coil be completely evaporated, and the pressure in B be kept constantly at P , by artificially removing the added vapor from B as rapidly as it is formed. The substance used must be one having a low boiling point even under heavy pressure, if the surrounding water is to be cooled much below the temperature of the air.

626. Action of Compressor. In Fig. 304, A represents the compressor, B the condenser, C the vaporizer, and D the expansion valve.

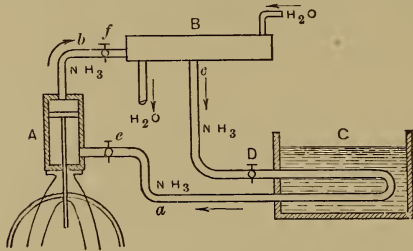

FIG. 304. Art. 626.—Vapor Compression Machine.

The compressor piston first moves upward, drawing in vapor from C . On the return stroke, the valve e is closed (the valves are, in practice, built in the compressor cylinder) and the vapor is compressed. When its pressure equals that in B , the valve f is opened, and discharge occurs. The valve f is now closed

and D is opened, the pressure falling from that in B to that in C . Described as a plant cycle, vapor is compressed along cb , Fig. 305, condensed in the condenser along ba , becoming liquid at a , and expands through the valve D along ad , its pressure falling so that it begins to boil violently. Further boiling gives the path dc , along which heat is removed from the vaporizer C . Refrigeration begins at d , as soon as the vapor has passed the expansion valve. The pipes beyond this valve are usually covered with snow. The vapor process always involves (1)

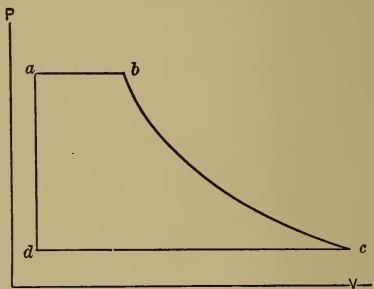

FIG. 305. Art. 626.—Vapor Cycle.

(2) the condensation of the vapor, (3) a lowering of its pressure and temperature by expansion, (4) evaporation of the liquid in the vaporizer, and (5) compression to the initial state. The underlying principles are two: the raising of the boiling point by pres-

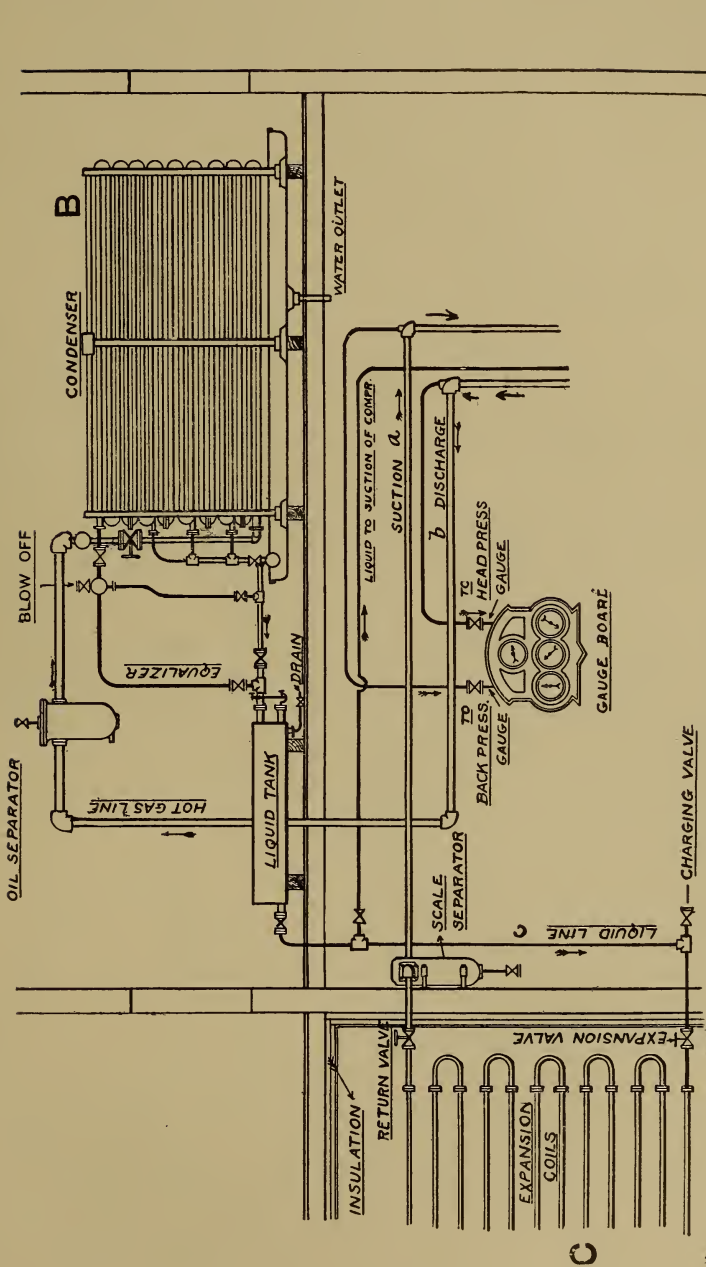

FIG. 306. Arts. 626, 647. — Refrigerating Plant. (De La Vergne Machine Company.)

sure, and the absorption of heat from surrounding bodies during evaporation. The pump analogy is useful. The vaporizer may be likened to a pit or well in which a fixed water level is to be maintained; by using a pump, the water may be raised to a level at which it will of itself flow away. The "pump" is the compressor, which raises the low-temperature heat of the vaporizer to a high-temperature heat which can flow away with the condensed water. The heat absorbed by the water is usually valueless for further service, as its temperature seldom exceeds 80° F.

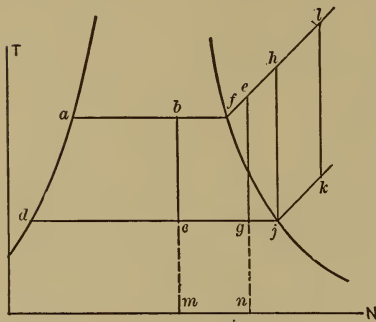

FIG. 307. Arts. 627, 628, 629, 630 — Vapor Refrigeration, Entropy Diagram.

Figure 306 represents a complete plant. The pipes *a, b* correspond to those similarly lettered in Fig. 304. The vaporizer may be merely an insulated room to be cooled, or a vessel of water or brine the temperature of which is to be lowered. There should be no loss of liquid in operation excepting by leakage.

627. Entropy Diagram. Figure 307 shows the various forms of entropy diagram, according as the substance is wet (*deba, dgefa*), dry (*djhfa*), or superheated (*djklfa*) as

it leaves the vaporizer. These are based on adiabatic paths. The actual operation is not a perfect Clausius cycle. During expansion the condition is one of constant total heat, giving such a path as *axd*, Fig. 308. This decreases the useful refrigerating effect area to *ydjz*. Compression may be made more economical than adiabatic, as in air compressors, by jacketing or spraying with oil or other liquid; the compressive path may then be, say, *jb*, decreasing the work expenditure to *axdj'b*, without altering the refrigerating effect. The path *jb*, if represented exponentially, will show a value of *n* less than that of *y* for the vapor in question. An actual indicator diagram from a vapor compressor is given in Fig. 309.

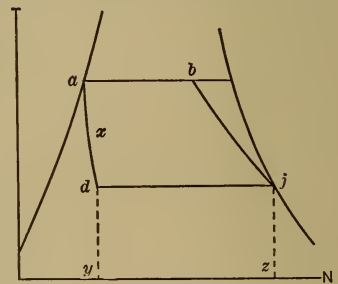

FIG. 308. Art. 627.—Modifications of Refrigerative Cycle.

628. Coefficient of Performance. For the cycle *dcba* of Fig. 307, in which the vapor at no state becomes superheated, maximum heat removed from the vaporizer is, say, xl . Heat is returned to it, however, along *ad*,* the liquid being lowered in temperature, to the extent $H - h$. The net refrigerating effect is

$$Q = xl - (H - h).$$

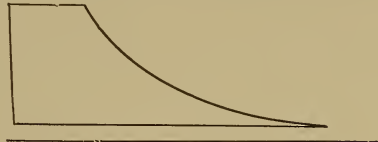

FIG. 309. Art. 627. — Ammonia Compressor Indicator Diagram.

The heat delivered to the condenser is XL , and the work done is

$$W = XL + H - h - xl.$$

The coefficient of performance is then

$$\frac{Q}{W} = (xl - H + h) \div (XL + H - h - xl).$$

Formulas may readily be derived for the coefficient when the vapor becomes superheated during compression or even before compression begins.

629. Multi-stage Operation: Superheat. A gain is possible by compressing in two or more stages. This gives an entropy diagram like that of Fig. 309 *a*. Fig. 307 shows that the highest coefficient of performance is attained when the

vapor remains saturated (wet or dry), throughout the cycle. Comparing the cycles *abcd* and *afegd*, for example, the added refrigeration effect *cgm* is gained at the cost of the proportionately greater expenditure of external work *cgef**b*. Superheating may be prevented by keeping the vapor always sufficiently wet at the beginning of compression, or by cooling during compression so as to avoid the adiabatic path, as described in Art. 198. "Dry" compression (in which superheating occurs) involves the use of jackets to permit of lubrication. Wet compression is far more frequently practiced. Heat interchanges with the cylinder walls probably justify a slight

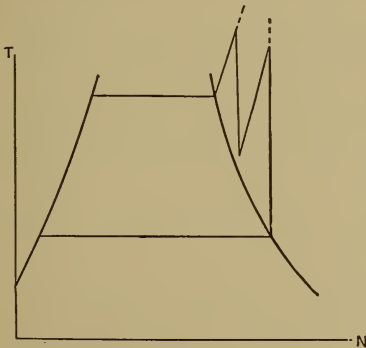

FIG. 309 *a*. Art. 629. — Two-stage Compression.

amount of superheating at the end of compression, just sufficient to ensure the absence of liquid at the beginning of the following suction stroke.

* In this ideal case, no cooling occurs between the condenser and the expansion valve or between the expansion valve and the vaporizer.

630. Choice of Liquid. The entropy diagram, Fig. 307, shows clearly one consideration which should influence the choice of a working fluid. The net refrigerating effect is reduced by the area under da , as explained in Art. 627. The steeper this line, the less the reduction; the longer the line dc , the greater is the refrigerating effect. Steepness of the line da means a *low specific heat of liquid*; a long line dc means a *high latent heat*. The best fluids for refrigeration are therefore those in which the ratio of **latent heat to specific heat of liquid** is large. From this standpoint, ammonia is among the most efficient of the vapors used. With carbon dioxide, the area under da forms a large deduction from the gross refrigerating effect.

631. Fluids Used. The vapors used for refrigeration include sulphuric ether, sulphur dioxide, methylic ether, ammonia, carbon dioxide, ethyl chloride, Pictet fluid (a mixture of carbon dioxide and sulphur dioxide), and steam. The vapor chosen must not be too expensive, and it must not exert a detrimental influence on the machinery. **Ether**, once commonly employed, is quite costly; its specific volume is so great that the machines were excessively bulky. The inward leakage of air resulting from the extremely low pressures necessary often heated the compressor cylinder. **Sulphur dioxide** unites with water to form sulphurous acid, which rapidly corrodes the cylinder when any moisture enters the system. The Pictet fluid has been used only by its inventor. Carbon dioxide, though inefficient, has been commercially satisfactory excepting where its low critical temperature (Art. 379) was objectionable. Ammonia is the fluid principally employed, especially in this country; the only serious objection to it seems to be the presence of occasional traces of moisture. It costs 20 to 25 cents per pound. The ordinary ammonia of commerce is a weak aqueous solution of the gas, H_3N . The ammonia employed in refrigerating machines is the nearly pure anhydrous liquefied gas, which has an intensely irritating and dangerous odor. It boils at $-26^\circ F.$ at atmospheric pressure.

Nitrous oxide, N_2O , has been lately introduced for refrigeration at very low temperatures (around $-100^\circ F.$). At such temperatures, NH_3 and SO_2 would have to be worked at high vacua, while CO_2 would solidify. The boiling point of N_2O at atmospheric pressure is below $330^\circ F.$ absolute. Its pressure-temperature curve lies between those of ammonia and of the more "permanent" gases. A table of its properties is given by Planck, *Zeits. f. d. gesammte Kälte-Industrie*, Oct., Nov., 1911.

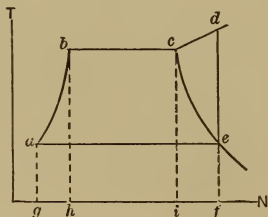

FIG. 309 b. Art. 632. — Dry Compression Cycle.

632. Comparisons. It is interesting to compare the effects following the use of various fluids between assigned temperature limits. Let the cycle be one in which the vapor is dry at the beginning of compression, $abcde$, Fig. 309 b. We have³

$$Q = aefg - gabh = L_e - (hb - ha).$$

$$W = g - L_e.$$

$$\begin{aligned} q &= gabcdf = gabh + hbc i + icdf \\ &= hb - ha + L_c + k(T_a - T_c). \end{aligned}$$

The value of T_d is $T_c \left(\frac{P_d}{P_c} \right)^{\frac{y-1}{y}}$, where y is the adiabatic exponent. The value of k is variable; but we have

$$k \log_e \frac{T_d}{T_c} = n_e - n_c, \text{ or } k \log T_d - k \log T_c = (n_e - n_c) \div 2.3,$$

in which T_d , T_c , n_e , and n_c are known. The following are specimen results (see tables, pp. 247, 248, 422, 424):

	NH ₃	SO ₂	H ₂ O
T_b	64.4° F.	64.4° F.	116° F.
T_a	5° F.	5° F.	32° F.
L_c	520.22	153.81	1038
L_e	582.1	169.745	1060
h_b	36.86	10.44	84
h_a	- 25.63	- 8.449	0
$P = P_b$	117.42	44.537	1.5
$P_e = P_a$	33.667	11.756	0.0886
T_d	175° F.	159° F.	484° F.
k	0.70	0.2023	0.493
n_e	1.20	0.3478	2.1832
n_c	1.065	0.3140	1.9412
y	1.33	1.272	1.298
q	659.91	191.8	1303
Q	519.61	150.86	976
W	77.81	22.05	243
$Q \div W$	6.68	6.82	4.02

633. Capacity. The common basis for rating refrigerating machines is in *tons of ice-melting effect* per 24 hr. The "ice-melting" effect is a conventional term denoting *the performance of 142 B. t. u. of refrigeration.* (The latent heat of fusion of ice is approximately 142 B. t. u.) Let Q be the heat removed from the vaporizer per cubic foot of fluid measured at its maximum volume during the cycle; then the tonnage per cubic foot is, theoretically,

$$T = Q \div (142 \times 2000).$$

Let D be the piston displacement, per 24 hr., in cubic feet; then the "rating" of the machine is

$$t = DT = DQ \div 284000.$$

In practice, this does not exactly hold, because the vapor is superheated by the cylinder walls during the suction stroke, its density being thus decreased below that of the saturated vapor. The reduction of capacity due to this superheating may be represented by the empirical expression

$0.04p \div P$, in which p is the pressure in the condenser, and P that at the vaporizer. The actual tonnage is then

$$\left(1 - 0.04 \frac{p}{P}\right) DQ \div 284000.$$

634. Economy. A practical unit of economy is the *pounds of ice-melting effect per pound of coal* burned in the boiler which drives the compressor engine. The refrigerating effect per cubic foot of fluid is, if we ignore self-evaporation (Art. 625),

$$\left(1 - 0.04 \frac{p}{P}\right) Q;$$

the work done in the compressor cylinder is $(q - Q)$; that in the engine cylinder is $C(q - Q)$, in which C is the *reciprocal of the combined mechanical efficiency of engine and compressor*, ranging from 1.15 to 1.25 for direct connected units. The foot-pounds of refrigerating effect per foot-pound of indicated work in the engine cylinder are then

$$\left(1 - 0.04 \frac{p}{P}\right) Q \div C(q - Q).$$

The **ice-melting effect** per horse power hour is then

$$\frac{1980000}{142 \times 778} \left(1 - 0.04 \frac{p}{P}\right) Q \div C(q - Q).$$

If, as in ordinary average practice, three pounds of coal are used per Ihp.-hr., the ice-melting effect per pound of coal is

$$\frac{1980000}{142 \times 3 \times 778} \left(1 - 0.04 \frac{p}{P}\right) Q \div C(q - Q).$$

635. Cooling Water. The heat absorbed by the condenser per cubic foot of piston displacement is

$$\left(1 - 0.04 \frac{p}{P}\right) q.$$

The number of pounds of water required per 24 hr. to absorb this heat, assuming the temperature rise of the water to be 30° , is

$$\left(1 - 0.04 \frac{p}{P}\right) Dq \div 30.$$

The gallons of water necessary per minute for each ton of "rating" (as defined in Art. 633) then become,

$$\left\{ \left(1 - 0.04 \frac{p}{P}\right) Dq \div \left(30 \times 60 \times 24 \times 8\frac{1}{3}\right) \right\} \div \left\{ \left(1 - 0.04 \frac{p}{P}\right) QD \div \left(142 \times 2000\right) \right\}.$$

This is about one gallon for the given range of water temperature; the usual range, however, is only about 15°.

636. Size of Compressor. If the fluid at the beginning of compression be just dry, and v be the specific volume and M the weight of this dry vapor circulated per minute, the total volume displaced per minute is Mv ; if N be the number of single strokes per minute, the piston displacement per single stroke of a double-acting compressor must be $D = Mv \div N$. This must be increased for superheating, as in Art. 633, the displacement becoming

$$Mv \div N \left(1 - 0.04 \frac{p}{P} \right),$$

and must be further corrected for clearance, as in Art. 233. A small additional increase is made in practice, to allow for the presence of air and moisture, etc.

637. Compressor Design. The refrigerating effect being assigned, the normal (unrefrigerated) vaporizer temperature and the possible condenser temperature are ascertained. These determine the cyclic limits. The type (single- or double-acting) and rotative speed of the compressor are then fixed. The refrigerating effect per pound of fluid under the assumed temperature conditions is now computed, and the necessary weight of fluid determined. The piston displacement may then be calculated and the power consumption and cooling water supply ascertained.

In most vapor computations, the specific volume of the liquid may be ignored. This does not hold with carbon dioxide, which is worked so near its critical temperature that the specific volume of the liquid closely approaches that of the vapor. The losses in the vapor compressor are similar in nature, though opposite in effect, to those in the steam engine cylinder. The transfer of heat between cylinder walls and working fluid causes the most serious loss; it is to be overcome in the same ways as are employed in steam engine practice.

638. Steam Compressors. In these, the working fluid is water, injected at ordinary temperature into a vacuum chamber. A portion of the water vaporizes, absorbing heat from the remainder and thus chilling it. The vapor is then slightly compressed, condensed, and **pumped** away or back to the vaporizer. The principle of action is the same as that of any vapor machine, but the pressure throughout is less than that of the atmosphere. The temperature cannot be lowered below 32° F. (Art. 632).

639. Ammonia Absorption Machine. This was invented by Carré. The theory has been presented by Ledoux and others (5); numerous developments of the original Carré apparatus have been described by Wallis-Taylor (6). Instead of using the mechanical force exerted by a compressor to raise the temperature of the fluid emerging from the vaporizer, this

elevation of temperature is produced by the application of external heat from fuel or steam coils in what is called the *generator*. The fluid then passes to the condenser, and through an expansion valve to the vaporizer. It cannot be returned directly to the generator, because the pressure there exceeds that in the vaporizer. An intermediate element, called the *absorber*, is used. The operation depends upon the well-known fact that water has the power of dissolving large volumes of volatile vapors; at 59° F., it dissolves 727 times its own volume of ammonia.* This solution produces an exothermic reaction; heat is evolved, amounting to about 926 B. t. u. per pound of water.† “The mechanical force which draws the vapor from the vaporizer in the compression system is here replaced by the affinity of water for ammonia vapor; and the mechanical force required for compressing the vapor is replaced by the heat of the generator, which severs this affinity and sets the vapor at liberty” (Kent). Ammonia is among the most soluble of the substances considered; other vapors may, however, be used (7).

640. Arrangement of Apparatus. The absorption apparatus is shown in outline in Fig. 310. At *A* is the **generator**, containing a strong solution of ammonia in water and suitably heated. The heat liberates ammonia gas, which passes through the pipe *a* to the **condenser** *B*. From this the liquefied ammonia passes out at *b* and is expanded through the valve *h*, taking up heat from the **vaporizer** *C*, as in the compression system. The **absorber** *D* is a vessel containing water or a weak solution of ammonia in water. The solution of vapor in this water produces a suction which continually draws vapor over from *C* to *D*. The solubility of ammonia in water decreases as the temperature increases, so that the evolution of heat in the absorber must be counteracted by jacketing that vessel with water

* The absorption increases as the temperature decreases and as the pressure increases.

† Generally, the heat evolved per pound of water is $(927x_0 - 142x_0^2)$ B. t. u., where x is the proportion of NH_3 to water, by weight.

‡ The boiling point of the solution is less than that of water at the same pressure. When x is the proportion by weight of NH_3 , the amount of such reduction is in deg. F.,

$$5.58a - 0.0868a^2 + 0.000591a^3,$$

in which $a = \frac{180000x}{1700 - 1700x}$. The approximate density of the solution is (water = 1) $1 - 0.43(x - x^2 + x^3)$.

The partial vapor pressure due to the steam is approximately

$$p \left(\frac{1700 - 1700x}{1700 + 100x} \right),$$

where p is the saturation pressure of pure steam at the generator temperature.

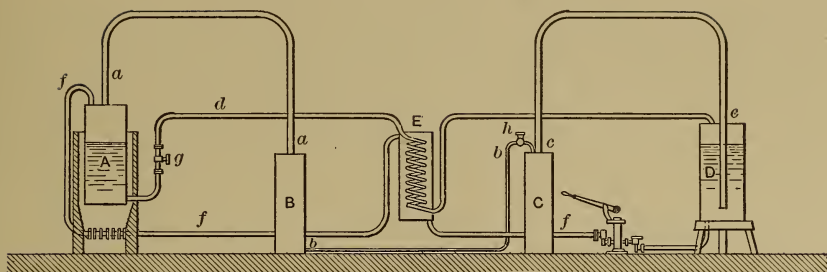

FIG. 310. Arts. 640, 642.—Ammonia Absorption Apparatus.

or installing water coils in the solution. The waste water from the condenser may be used for this cooling. The more concentrated portion of the liquid in *D* is now pumped through *f* to *A*, while the weaker solution is drawn off from the bottom of *A* and returned to the top of *D* through *d*. A coil heater at *E* provides for the interchange of heat, thus warming the liquid entering *A* and cooling that entering *D*, as is to be desired.

641. Cycle. From the condenser to the vaporizer, the operation is identical with that in a compression plant. The absorber and generator replace the compressor. The rise in pressure occurs between the pump *f* and the generator outlet *a*. In Fig. 311, *B* may be taken as the state of the gas entering the condenser, in which it is liquefied along *BA*. Expansion reduces its pressure, giving the path *AJ*. In passing through the vaporizer, the liquid is evaporated along *JC*. It cannot be returned directly to the generator; nor can it advantageously be returned by pumping, because very little solution would occur at the high temperature maintained in the generator. It is therefore absorbed by water in *D*, Fig. 310, at a pressure nearly equal to that in *C*, and transferred to the generator,

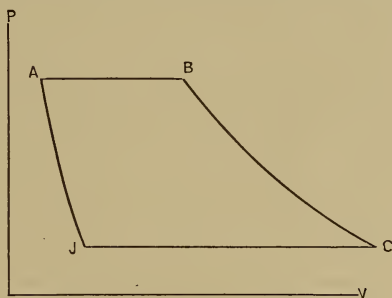

FIG. 311. Arts. 641, 642.—Absorption Cycle.

where its pressure rises, as along *CB*, Fig. 311. From *C* to *B*, the vapor is in solution; but its pressure and temperature are increased by the application of heat, just as in compression machines they are increased at the expenditure of external work. The cycle is the same as that of the compressive apparatus.

642. Comparison of Systems. The temperature attained at *B*, Fig. 311, is practically the same as in dry compressive systems; it is $T_B = T_C \left(\frac{P_B}{P_C} \right)^{\frac{\gamma-1}{\gamma}} = T_C \left(\frac{P_B}{P_C} \right)^{0.25}$

for ammonia ($y = 1.33$). The refrigeration per pound of pure dry vapor is $Q = (1 - X)L$, as with the compressor. Ideally, the heat evolved in the absorber should be approximately sufficient to evaporate the solution in the generator. Actually, this heat is largely lost, on account of the necessity of cooling the absorber. Assuming that all the steam consumed by the pumps is afterward employed in the generator, the heat consumption of the absorption apparatus includes the following four items:

R , that necessary to evaporate the cold water drained back from a portion of the condenser tubes;

E , that necessary to raise the temperature of the solution entering the generator to that of saturation;

S , that necessary to distill the ammonia in the generator (latent heat plus heat of decomposition);

W , necessary to raise the temperature of the vapor during superheating.

Symbolically, $H = W + S + E + R$. Items E and R may be regarded as offset by the friction losses in the compressor system. We may then put $H = W + S$ in the absorption system. "A rough comparison of the two systems is as follows: At a suction pressure of about 34 lb. absolute, at which the vaporizer temperature is 5° (with ammonia), a good non-condensing steam engine will consume heat amounting to about 969 B. t. u. per pound of ammonia circulated, the condenser temperature being 65° . Under the same conditions, the absorption machine will consume about 72 B. t. u. in raising the temperature and about 897 B. t. u. in distilling the ammonia; whence $H = 72 + 897 = 969$. The two machines are thus equal in economy for a suction pressure of 34 lb." As the vaporizer temperature falls below 5° , the economy of the absorption system, though reduced, becomes better than that of a compressor with a non-condensing engine. The reverse is the case when the vaporizer temperature rises. Compared with condensing engine driven compressors, the economy is about equal for the two types when the vaporizer room temperature is zero. Where a low back-pressure is required, as in ice-making, the absorption system is thermodynamically superior. The absorption system requires about the same total amount of cooling water as is needed in a compression system operated by a *condensing* steam engine.

A fairly satisfactory computation of the heat balance presented by Spangler (5) is as follows: *Let steam at 35 lb. absolute pressure, 0.9 dry, be supplied for heating the generator of a 15-ton machine (24-hour actual capacity). The condenser temperature is $80^\circ F.$, that of the vaporizer is $10^\circ F.$ and that of the absorber is kept at $100^\circ F.$ The generator solution contains 25 per cent of NH_3 , the absorber holds a 12 per cent solution. All cooling water rises from 60° to 80° in temperature.*

The temperature in B (Fig. 310) being 80° , the ammonia pressure (page 486) is 154.7. The steam pressure at this temperature is negligible. Since the passage between A and B is open, the pressure in A will be the same as that in B —154.7 lb.; the vapor being somewhat superheated in A .

The solution in A is 0.25 NH_3 . If it were pure water, its temperature would at the given pressure be $360.9^\circ F.$ The third foot-note to Art. 640 gives

$$a = \frac{180000 \times 0.25}{1700 - 425} = 35.4, \text{ temperature reduction} = (5.58 \times 35.4) - (0.0868 \times 35.4^2) \\ + (0.000591 \times 35.4^3) = 115^\circ F.,$$

so that the boiling point of the solution is $360.9 - 115 = 246^\circ \text{ F}$. At this temperature, the pressure of saturated steam is 27.8 lb.; the partial steam pressure in the generator is then (Art. 640)

$$27.8 \left(\frac{1700 - 425}{1700 + 25} \right) = 20.5 \text{ lb.},$$

and the partial pressure of NH_3 is $154.7 - 20.5 = 134.2 \text{ lb}$.

The pressure in *C* and *D* is that corresponding with the temperature (10° F) in *C*; 37.9 lb.

Each cubic foot of vapor leaving the generator consists of 1 cu. ft. of superheated steam at 20.5 lb. pressure and 246° F ., and 1 cu. ft. of superheated NH_3 at 134.2 lb. pressure and 246° F . The density of the steam is found to be 0.0495. That of the ammonia (Art. 403) is about 0.3088.

Any vapor condensing between *A* and *B* is not allowed to enter *B*, but is separately drawn off through a *rectifier*, as shown in Fig. 310, and drained back to the generator. If this condensation were not removed, the NH_3 absorbed by the water formed would be carried to the absorber. The temperature at the rectifier will be slightly above that at the condenser, say 85° F . The density of water vapor at this temperature is 0.00183. The ammonia has now been brought to a pressure of 154.7 lb. and a temperature of 85° , at which its specific volume (Art. 403) is, nearly, 2.09 cu. ft. Its actual volume is $0.3088 \times 2.09 = 0.641 \text{ cu. ft}$. It contains $0.641 \times 0.00183 = 0.0012 \text{ lb}$. of water. The rectifier has then removed $0.0495 - 0.0012 = 0.0483 \text{ lb}$. of water.

The condensed water absorbs some of the ammonia vapor. Under the pressure of 154.7 lb. and at 85° F ., 1 lb. of water absorbs 2.36 lb. of NH_3 . The weight of NH_3 absorbed is then $0.0483 \times 2.36 = 0.114 \text{ lb}$. The quantity of NH_3 passing on to the condenser is consequently $0.3088 - 0.114 = 0.1948 \text{ lb}$., accompanied by 0.0012 lb. of steam.

Upon condensation in *B*, the 0.0012 lb. of water absorbs $0.0012 \times 2.33 = 0.0028 \text{ lb}$. of NH_3 , and must be drained back to the generator. The anhydrous liquid NH_3 leaving the condenser now amounts to $0.1948 - 0.0028 = 0.192 \text{ lb}$.

The pump must handle a sufficient amount of strong liquor from *D*, and the generator must return a sufficient amount of weak liquor to *D*, to cause a decrease in strength of solution from 25 per cent to 12 per cent. When the pump draws off 100 parts of solution, containing 25 of ammonia, the generator must return 100 parts, containing 12 of ammonia. The weight of ammonia decreases $25 - 12 = 13$, and the weight of solution increases 13, or from 75 to $75 + 13 = 88$. The quantity of strong liquor that must be handled per pound of ammonia is then $\frac{88}{13} = 6.77 \text{ lb}$., and that of weak liquor is $6.77 - 1.0 = 5.77 \text{ lb}$.

The pump must handle $6.77 \times 0.192 = 1.3 \text{ lb}$. of strong liquor, and the generator must return $5.77 \times 0.192 = 1.108 \text{ lb}$. of weak liquor, per cubic foot of NH_3 discharged from the generator.

In passing the valve *h*, the pressure falls from 154.7 lb. to that corresponding with the temperature 10° F . — 37.9 lb., and there will be vaporized

$$0.192 \frac{h_{80} - h_{10}}{L_{10}} = \frac{0.192(55 + 30)}{585} = 0.0279 \text{ lb.}, \text{ (Art. 625),}$$

the remaining liquid, $0.192 - 0.028 = 0.164 \text{ lb}$., being evaporated at *C*.

Heat Computation. In the *rectifier*, 0.0495 lb. of H_2O at 20.5 lb. pressure and 246° F. is reduced to 85° F. and saturation (0.59 lb. pressure). Of this amount 0.0483 lb. is condensed. The heat given up is $\{0.0495k(T-t)=0.0495 \times 0.48 \times (246-85)=3.82 \text{ B. t. u.}\} + \{0.0483L_{85}=0.0483 \times 1044=50.5 \text{ B. t. u.}\}$ Besides this, 0.3088 lb. of NH_3 at 134.2 lb. pressure and 246° F. is reduced to 85° F. and 154.7 lb. pressure; of which weight, 0.114 lb. is absorbed by the water. The ammonia gives up in cooling $0.3088 \times 0.508 * (246-85)=25.1 \text{ B. t. u.}$ The absorption of NH_3 evolves

$$0.0483 \left\{ 927 \left(\frac{0.114}{0.0483} \right) - 142 \left(\frac{0.114}{0.0483} \right)^2 \right\} = 0.114 \left\{ 927 - 142 \left(\frac{0.114}{0.0483} \right) \right\} \\ = 67.6 \text{ B. t. u.} \quad (\text{Art. 640}).$$

In the *condenser*, 0.0012 lb. of water is reduced from 85° to 80° and condensed, giving up $0.0012 \{ (0.48 \times 5) + 1047 \} = 1.26 \text{ B. t. u.}$ Also, 0.1948 lb. of ammonia is cooled from 85° to 80° ($0.1948 \times 0.508 \times 5 = 0.5 \text{ B. t. u.}$) and 0.0028 lb. is absorbed by water $\left(0.0028 \left\{ 927 - 142 \left(\frac{0.0028}{0.0012} \right) \right\} = 1.67 \text{ B. t. u.} \right)$. The remaining 0.192 lb. of ammonia is now condensed, giving up $0.192L_{80}=0.192 \times 499.4=95.9 \text{ B. t. u.}$

At the *expansion valve* and *vaporizer*, 0.192 lb. NH_3 is converted from liquid at 80° to dry vapor at 10°, absorbing $0.192 (h_{10} - h_{80} + L_{10}) = 0.192 (-30 - 55 + 585) = 96 \text{ B. t. u.}$

In the *absorber*, 0.192 lb. NH_3 is raised in temperature from 10° to 100° ($0.192 \times 0.508 \times 90 = 8.75 \text{ B. t. u.}$); this is absorbed so as to raise the strength from 12 to 25 per cent. The heat evolved is (Art. 640),

$$(927x_0 - 142x_0^2) \text{ B. t. u. per lb. of water,}$$

where x_0 = proportion of NH_3 to water. This gives, for an increase of strength from A to B (percentage of total), per pound of *ammonia*, a heat evolution of

$$927 - 142 \left(\frac{B}{100-B} + \frac{A}{100-A} \right) \text{ B. t. u.,}$$

which for our conditions gives

$$0.192 \left\{ 927 - 142 \left(\frac{25}{75} + \frac{12}{88} \right) \right\} = 164.3 \text{ B. t. u.,}$$

as the heat liberated by solution.

The *generator* must raise the temperature of 0.192 lb. NH_3 from 100° to 246° and reduce the strength from 25 to 12 per cent. In raising the temperature, $(0.192 \times 0.508 \times 146) = 14.2 \text{ B. t. u.}$ are employed. In the partial distillation, the same amount of heat is consumed as was liberated at the absorber, *viz.*, 164.3 B. t. u. Besides this, the generator raises the temperature of the 0.0483 lb. of water (received from the rectifier) from 85° to saturation, evaporates it and raises its temperature

* Art. 403.

to 246°. This requires $0.0483 \{h_{20.5} - h_{85} + L_{20.5} + 0.48(246 - t_{20.5})\} = 0.0483 \{197.45 - 53.02 + 959.15 + (0.48 \times 16.7)\} = 53.75$ B. t. u. In addition, the 0.114 lb. of NH_3 received with the water from the rectifier must be heated to 246°, and distilled off. This requires $0.114 \times 0.508 \times 161 = 9.3$ B. t. u. for the former operation and

$$0.114 \left\{ 927 - 142 \left(\frac{0.114}{0.0483} \right) \right\} = 67.5 \text{ B. t. u. for the latter.}$$

The condenser also returns to the generator 0.0012 lb. of water and 0.0028 lb. of NH_3 , both at 80° F. The heat necessary to handle these amounts in the same way as the rectifier drainage is

$$0.0012 \{197.45 - 48.03 + 959.15 + (0.48 \times 16.7)\} = 1.33 \text{ B. t. u. (water);}$$

$$0.0028 \times 0.508 \times 161 = 0.23 \text{ B. t. u. (to superheat the ammonia);}$$

$$0.0028 \left\{ 927 - 142 \left(\frac{0.0028}{0.0012} \right) \right\} = 1.67 \text{ B. t. u. (to distil the ammonia).}$$

At the pump, 1.3 lb. of strong liquor must be raised in pressure from 37.9 lb. to 154.7 lb. The absolute density of the 25 per cent solution being 56.9 (see Art. 640), the work of the pump is

$$\frac{1.3}{56.9} \times \frac{144(154.7 - 37.9)}{778} = 0.5 \text{ B. t. u.}$$

Summary: In the rectifier, there were lost $3.82 + 50.5 + 25.1 = 79.42$ B. t. u. Adding the heat contributed by the absorbed ammonia, 67.6, we have 147.02 B. t. u. as the net expenditure of heat at that point.

At the condenser, there were losses of $1.26 + 0.5 + 1.67 + 95.9 = 99.33$ B. t. u. At the vaporizer, the fluid received 96 B. t. u.

At the absorber, absorption caused a loss of 164.3 B. t. u. but the heat added to the ammonia consumed 8.75 B. t. u., so that only 155.55 B. t. u. were rejected to the cooling water.

At the generator, the supply of heat was $14.2 + 164.3 + 53.75 + 9.3 + 67.5 + 1.33 + 0.23 + 1.67 = 312.28$ B. t. u.

<i>Total Heat Received.</i>		<i>Total Heat Accounted for.</i>	
Generator,	312.28	Rectifier,	147.02
Pump,	0.5	Condenser,	99.33
Vaporizer,	96.0	Absorber,	155.55
	<hr/>		<hr/>
	408.78		401.90
		Unaccounted for,	6.88
			<hr/>
			408.78

The error in the heat balance is thus about $1\frac{1}{2}$ per cent.

For a 15 ton machine, the effect required at the vaporizer is $15 \times 2000 \times 142 = 4,260,000$ B. t. u. per 24 hours. The generator effect necessary per minute is then

$$\frac{4,260,000}{24 \times 60} \times \frac{312.28}{96} = 9650 \text{ B. t. u.}$$

Each pound of steam contributing $0.9 L = 0.9 \times 938.9 = 845$ B. t. u., the weight of steam needed per minute is $\frac{96 \times 845}{8 \frac{1}{2}} = 11.4$ lb. A total effect of 401.9 B. t. u. is produced by cooling water per 96 B. t. u. of refrigeration. The weight of water required per minute is then

$$\frac{4,260,000}{24 \times 60} \times \frac{401.9}{96} \div (80 - 60) = 620 \text{ lb.}$$

643. Steam Absorption Machines. A water-vapor machine of the class described in Art. 638 may dispense with the compressor, the steam being absorbed by and generated from solutions in sulphuric acid. This form of apparatus has been in use for at least a century, having been successfully developed by Carré and others (8).

DETAILS AND COMMERCIAL STANDARDS

644. Direct Expansion. When the refrigerating fluid is itself circulated in the room or through the material to be cooled, the system is that of **direct expansion**. While simple and economical, there are objections to this type of plant. The least movement of the expansion valve changes the lower pressure and temperature, and consequently the temperature of the room to be cooled. The introduction of a substance like ammonia is often considered too hazardous in rooms where valuable materials like furs would be damaged by any leakage.

645. Brine Circulation. By expanding the refrigerating fluid in coils immersed in some harmless liquid, like salt water, the former may be kept wholly within the power plant; the cooled water is then circulated through the rooms to be refrigerated by means of a pump. The operation is wasteful, because it involves an irreversible rise in temperature between working fluid and brine, but is often preferred for the reasons given. The brine serves as a "fly wheel for heat," smoothing out the variations in temperature which occur with direct expansion; but a secondary circulating system is more expensive in installation and operation. In addition to the usual apparatus, there must be supplied a **brine tank**, which now becomes the **vaporizer**, coils within the brine tank, and a **brine pump**. The cooling coils in the refrigerated room, and the piping thereto, must be supplied as in direct expansion; they are, however, rather less expensive.

646. Fluids. Salt brine is commonly used rather than water, since the freezing point of the former may be as low as -5° F. This fluid is detrimental to cast-iron fittings, and these are ordinarily made extra heavy when used for brine circulation. Chloride of calcium in solution* permits of a still lower temperature; it may solidify at as low a temperature as -54° F. A solution of magnesium chloride is occasionally used. Salt brine cannot be left in the system after the circulation ceases, as the salt settles out and the freezing point is raised.

* A study of the specific heats of some calcium chloride solutions is contained in the *Bulletin of the Bureau of Standards*, 6, 3.

647. Brine Circulation Plant. Figure 312 shows a complete plant. In operation, the compressor is first started, drawing the air out of the pipe coils. A drum of anhydrous ammonia is placed at *B*, and the contents allowed to run into the liquid receiver through the valve *C*. The expansion valve *D* is then opened and liquid ammonia passes through to the brine tank. The valves *A* and *F* are kept open until the odor of ammonia is evident. They are then closed, the valve *L* is opened, and the water turned on at the condenser. The compressed vapor is now liquefied in the condenser, its temperature falling within 20° of that of the cooling water in usual practice. The brine pump *G* is started, circulating the chilled brine through the refrigerated room *H*, and the speed of the compressor is increased until the temperature of the fluid in the brine tank is about 20° below the required temperature in *H*. Ammonia is supplied at *C* until the level in the receiver remains constant. The supply is then cut off. At the beginning of the operation, all of the ammonia will be evaporated in *E*, and the vapor will be highly superheated during compression. As the brine is chilled, the temperature of the discharged vapor falls, and frost forms on the outside of the pipe *I*, gradually approaching the compressor. If the supply of fresh liquid is stopped at this point, superheating will continue to occur, producing "dry" compression. In "wet" compression, the compressor inlet becomes heavily frosted and the outlet pipe is sufficiently cool to be touched by the hand. With adequate jacketing, etc., the dry system may be in practice as economical as the wet (Art. 629), but additional care is necessary to avoid leakage at the stuffing boxes. A direct expansion system has already been shown in Fig. 306.

648. Indirect Refrigeration. In some cases, neither brine circulating coils nor direct expansion coils are used in the cooling room, but air is blown over a bank of coils and thence through ducts to the room. This constitutes *indirect refrigeration*, providing ventilation as well as cooling. In direct refrigeration, provision is sometimes made for drawing off foul air by vertical flues. In certain applications, arrangements are made for washing or filtering and drying the air supply introduced.

649. Abattoirs, Packing Houses. Refrigeration here plays an important part. Either direct expansion or brine circulation may be employed, the coils being located along the side walls near the ceiling, or suspended from the ceiling, if head room will permit. The latter is the better arrangement. Moisture from the atmosphere of the room rapidly condenses on the outside of the pipes, and provision must be made for removal of the drip. The atmosphere of the room rapidly becomes dry.

650. Cold Storage. For preserving vegetables, fruits, poultry, eggs, butter, milk, cheese, fish, meats, etc., either in permanent storage or during transportation, mechanical refrigeration has been widely applied. Temperatures of from 25° to 40° F. are usually maintained, the temperature being lowered gradually. Some substances keep best when actually frozen. Mechanically cooled refrigerator cars have been described by Miller (9). For all storage-room applications, the fundamental principles underlying the computation of the amount and dis-

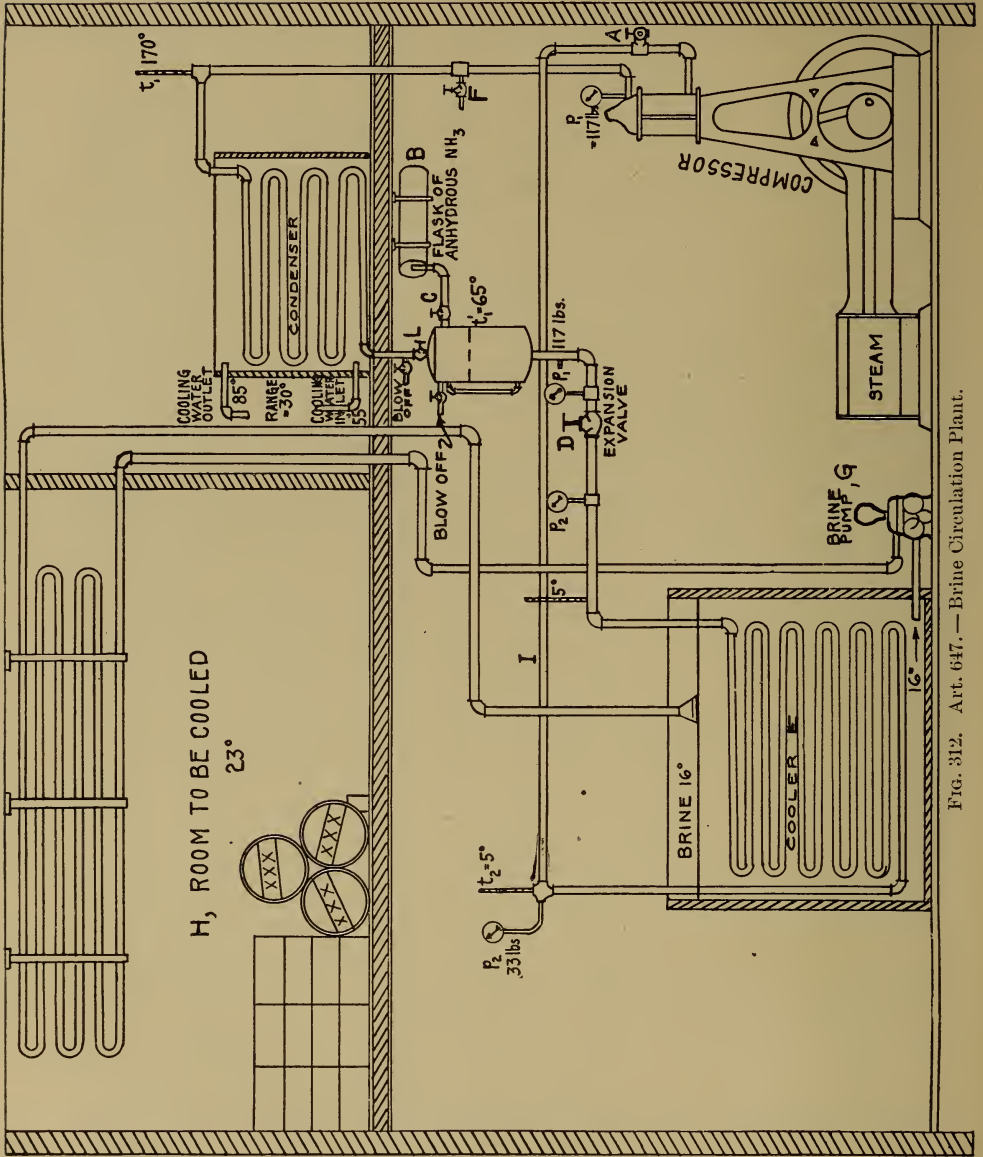

Fig. 312. Art. 647. — Brine Circulation Plant.

tribution of coil surface are precisely those employed in the design of heating and ventilating systems. Reference should be made to the works of Siebel (10) and Wallis-Taylor (11). The thorough insulation of the rooms and of the conducting pipes is of much importance.

651. Other Applications. Mechanical refrigeration is universally employed in breweries, for cooling of the cellars and the wort, as well as for cooling during fermentation (attemperator system) (12). It is popular in marine service, where the space occupied by stored ice, and its shrinkage, would be serious items of expense. It is applied in candy factories, for cooling chocolate; in candle and paraffin works and linseed-oil refineries for precipitating out solid waxes from mixtures; in dairies for cooling the milk; in tea warehouses, dynamite factories, in the manufacture of photographic dry plates, in wine cellars, soda-water establishments, sugar refineries, chemical works, glue factories, and for the winter storage of furs. The losses experienced in marine transportation of cattle on the hoof have been greatly reduced by cooling the space between decks. Refrigeration has also been used for congealing quicksand during excavation and tunneling operations in loose soil.

A recent application is in the formation of indoor skating ponds. These are frozen by direct expansion through submerged coils. A fresh surface is frozen on whenever necessary, and this is kept smooth by the use of a planing machine. Pipe-line refrigeration from central stations is being practiced in at least nine American cities; the present status of this public service has been studied by Hart (13).

652. Ice Making. This is one of the most important applications. The manufacture of ice may be carried on as an adjunct to the ordinary operation of any refrigerating plant. The product is from an hygienic standpoint immeasurably superior to the usual natural ice. In practice, three systems are used: the plate, the stationary cell, and the can, the last being of most importance.

653. Plate System. Large, shallow, hollow, rectangular boxes are immersed in a tank containing the water to be frozen, dividing the body of water into narrow sections, corresponding to the "plates" of ice to be formed. Through the hollow boxes, a solution of chilled brine circulates; in some cases, however, this brine is quiescent, being chilled by coils immersed in it, in which coils brine from the compressor plant circulates. A "plate" 14 in. thick may be produced in from 9 to 14 days. The plates when formed are loosened by circulating warm brine for a few moments, and are then hoisted out by cranes.

654. Stationary Cell System. A large number of approximately cubical tanks, with hollow walls and bottoms, are set in a frame. Brine is circulated through the walls. A "cake" of ice is gradually formed within the tanks. This is loosened in the same manner as plate ice.

655. Clear Ice. Much difficulty has been experienced in securing a product free from the characteristic porous, granular structure. A clear ice has been

found to be most probable when the temperature of the operation is not too low, when the water is agitated during cooling, and when the layers are thin, as in the plate system or with shallow, stationary cells. To provide these conditions usually involves delay, trouble, or expense. The clear ice of the present day is produced by the use of *distilled water*. This may be obtained by condensing the exhaust from the compressor engine, or by using that exhaust in an *evaporator* to distill in vacuo a fresh supply of water. Traces of cylinder oil must in the former case be thoroughly eliminated, and the water carefully filtered.

656. Can System. The use of distilled water from the engine exhaust in portable cans is at present standard practice. The cans, of plain galvanized iron, stand in a tank containing a circulating solution of brine, the temperature being somewhat below 32° . Blocks of 300 lb. weight are produced in from 50 to 60 hr. — about one fourth the time usually required with the plate system. The ice is loosened by lowering the cans for a moment in warm water. The various wastes of water, when the condensation from the engine is employed, require that the amount fed the boiler shall be about 33 per cent in excess of the amount of ice to be made. A highly economical steam engine is thus undesirable. "The can system requires about one fourth the floor area and one twelfth the cubical space that are needed by the plate system for the same output, while it is about four times as rapid, and costs initially about 25 per cent less."

In a system recently introduced, large hollow cylinders, through which ammonia circulates, are revolved in a freezing tank. A thin film of ice forms on the outside of the cylinders, and is scraped off by knives and pumped in slushy condition to a hydraulic press, where it is formed into cakes. The process is continuous and requires little labor. The clearness of the ice depends upon the pressure to which it is subjected.

657. Details. The pressure range is usually from 190 to 15 lb. gauge approximately. The brine may be ordinary salt brine, consisting of 3 lb. of medium ground salt per gallon of water (specific heat about 0.8), or calcium chloride brine, in the proportion of 3 to 5 lb. of chloride to one gallon, or, on the average, at about 23° Bé., weighing $13\frac{1}{2}$ lb. per gallon and permitting of a temperature of -9° F. The specific heat of this solution is about 0.9. The brine must be periodically examined with a salinometer. The ice-making capacity is *not the same* as the *ice-melting effect* described in Art. 633. To produce actual ice, the water must be cooled from its initial temperature to the freezing point, while the ice is usually formed at a temperature considerably below 32° . Roughly speaking, about one-half ton of actual ice may be made per ton of rated capacity. The productive capacity is further reduced by the losses attending the handling of the ice.

658. Tonnage Rating. The ice-melting effect of a machine working between the pressures p and P is, from Art. 633,

$$t = m \left(1 - 0.94 \frac{p}{P} \right) D (1 - X) L \div (142 \times 2000),$$

in which m is the density of the vapor at the suction pressure.

Since X is determined by p and P , the capacity depends directly upon the pressure range and the piston displacement. The American Society of Mechanical Engineers (14) has standardized these pressures by assigning 90° and 0° F. as the corresponding temperature limits. This makes the lowest possible room temperature about 15° F. with direct expansion and about 25° F. with brine circulation. Lower temperatures are frequently required. The lower of the assigned temperatures also fixes the value of m . For any other pressures, q , Q , at the state M , x , l , the tonnage capacity would be

$$T = M \left(1 - 0.04 \frac{q}{Q} \right) D(1-x)l \div (142 \times 2000); \text{ whence}$$

$$\frac{T}{t} = \frac{M \left(1 - 0.04 \frac{q}{Q} \right) (1-x)l}{m \left(1 - 0.04 \frac{p}{P} \right) (1-X)L}$$

659. Compressor Proportions. The builders of machinery do not in all cases rate their machines on this basis. Many of them merely state the piston displacement (which may range from 6500 to 8700 cubic inches per minute per ton of nominal capacity) or the weight of vapor circulated under given pressure conditions. Power rates usually range from one to two horse power at the engine per ton of capacity; piston speeds vary from 125 to 600 ft. per minute.

660. Tests. A standard code for trials of refrigerating machines is under consideration by a committee of the American Society of Mechanical Engineers, a preliminary report having already been made (15). Results of tests are stated in **ice melting effect in pounds per pound of coal or per indicated horse power hour** at the compressor engine. Where the coal is not measured, 3 lb. of coal per hour are often assumed to be equivalent to one horse power. Let a be the ice melting effect per indicated horse power: then

$$142 a \div (1980000 \div 778) = 0.0557 a$$

is the efficiency from engine cylinder to cooling room. Let b be the ice-melting effect per pound of coal containing 14,000 B. t. u.; then

$$142 b \div 14000 = 0.01015 b$$

is the efficiency from coal to cooling room. A few well-known tests will be quoted.

661. Air Machines. Ledoux quotes tests (16) in which the ice-melting effect per pound of coal was from 3.0 to 3.42 at 3 lb. coal per Ihp.; the efficiencies from coal to cooling room being respectively only 0.0304 and 0.0346. A Bell-Coleman machine at Hamburg, tested by Schröter (17) gave from 354 to 371 calories of refrigeration per Ihp.-hr., the efficiency from the engine to cooling room being therefore from 0.551 to 0.580. The range of temperatures was very low. About half the power expended in the compressor is ordinarily recovered in the expansion cylinder.

662. Compression Machines. Most tests have been made with ammonia. Ledoux tabulates (18) ice-making effects per pound of coal ranging from 9.86 to 46.29, based on 3 lb. of coal per horse power; the corresponding efficiencies being from 0.10 to 0.469. A number of tests by Schröter gave from 19.1 to 37.4 lb., or from 0.194 to 0.379 efficiency. Shreve and Anderson obtained 21 lb., or 0.213 efficiency (19). Anderson and Page (20) obtained 18.261 lb. of ice-melting effect per pound of coal containing 12,229.6 B. t. u. per pound; or 65.79 lb. per Ihp. The efficiency from engine to refrigeration was 3.65; from coal, it was 0.211. The pressure range was from 28.88 to 132.01 lb. absolute. Denton (21) reported 23.37 lb. of ice-melting effect per pound of coal on the 3 lb. basis, working between 27.5 and 161 lb. pressure. The ice-melting capacity for 24 hr. was 74.8 tons, the average steam cylinder horse power, 85; whence the engine to room efficiency was $(23.37 \times 3 \times 142) \div 2545 = 3.92$, and the coal to room efficiency about 0.236. The efficiency from coal to engine cylinder was then $0.236 \div 3.92 = 0.0602$. A series of tests by Schröter (22) gave from 1674 to 4444 calories of refrigeration per **compressor** horse power, the corresponding efficiencies being therefore from 2.61 to 6.91; the engine to room efficiency might be 15 per cent less, say from 2.21 to 5.87. A Pictet fluid machine (23) gave 3507 calories per horse power in the steam cylinder, or 5.5 efficiency. The reason for these high values, exceeding unity, has been stated in Art. 621. The steam engine efficiencies in none of these tests exceeded 15 per cent; it did not average much over 5 per cent; an average efficiency of 0.237 from coal to room corresponds to a coefficient of performance of about

$$0.237 \div 0.05 = 4.74 \text{ (neglecting friction of mechanism).}$$

The engine to room efficiency is equal to the actual coefficient of performance multiplied by the mechanical efficiency of engine and compressor.

663. Ammonia Absorption Machines. Assuming an evaporation of 11.1 lb. of water from and at 212° F. per pound of combustible, Ledoux (24) reports a test in which 20.1 lb. of ice-melting effect were produced per pound of coal, the overall efficiency being thus 0.204. A seven-day test by Denton (25) gave 17.1 lb., based on 10 lb. of steam per pound of coal, the corresponding efficiency being about 0.173. The pressure range was from 23.4 to 150.77 lb. absolute. The tem-

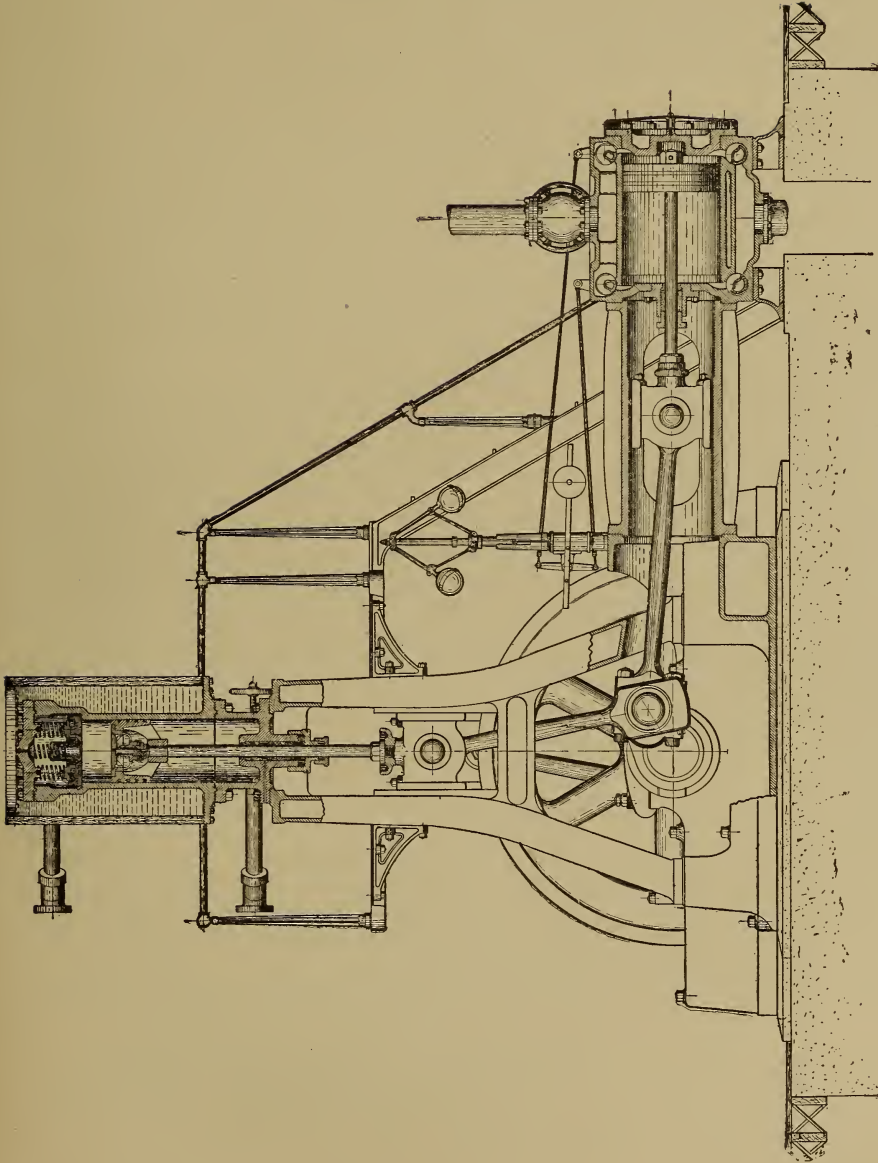

FIG. 313. Art. 604. — York Refrigerating Machine.

perature range was from 272° to 80° F.; the coefficient of performance for the Carnot cycle would have been 2.83. The equivalent efficiency from coal to compressor cylinder in a compression machine must then have been at least

$$0.173 \div 2.83 = 0.0613;$$

or from coal to engine cylinder, about

$$1.2 \times 0.0612 = 0.07344.$$

664. Commercial Types. Compressors may be driven directly from a steam cylinder, or by belt. Any form of slow-speed engine may be used for driving; a favorite arrangement is to have the steam cylinder horizontal and the ammonia cylinder vertical, as in Fig. 313. Tandem or cross-compound engines may be used. The ammonia condenser may be an ordinary surface condenser, or an atmospheric condenser of the form described in Art. 585, consisting of a coil of exposed pipes over which streams of water trickle. In other types, the ammonia coils are submerged in a tank of circulating water. Cooling towers are used where there is an inadequate water supply.

(1) Wallis-Taylor, *Refrigeration, Cold Storage, and Ice Making*, 1902. (2) Zeuner, *Technical Thermodynamics* (Klein tr.), I, 384. (3) *Op. cit.* (4) *Proc. Inst. Mech. Eng.*, 1881, 105; 1886, 201. (5) *Ice-making Machines*, D. Van Nostrand Co., 1903; Spangler, *Applied Thermodynamics*, 1910. (6) *Op. cit.*, p. 154 *et seq.* (See also the paper by Ophuls, in *Power*, Apr. 23, 1912.) (7) Wallis-Taylor, *op. cit.*, p. 25. (8) Wallis-Taylor, *op. cit.*, pp. 24-32. (9) *Stevens Indicator*, April, 1904; *Railroad Gazette*, October 23, 1903. (10) *Compend of Mechanical Refrigeration*. (11) *Op. cit.* (12) *Op. cit.*, 381. (13) *Engineering Magazine*, June, 1908, p. 412. (14) *Transactions*, 1904. (15) *Transactions*, XXVIII, 8, 1249. (16) *Ice-making Machines*, 1906, Table A. (17) *Untersuchungen an Kaltemaschinen*, 1887. (18) *Loc. cit.* (19) Wood, *Thermodynamics*, 1905, 352. (20) *Ibid.*, 348. (21) *Trans. A. S. M. E.*, XII. (22) Peabody, *Thermodynamics*, 1907, 414. (23) Schröter, *Verg. Vers. an Kaltemaschinen*. (24) *Loc. cit.* (25) *Trans. A. S. M. E.*, X.

SYNOPSIS OF CHAPTER XVIII

A heat cycle may be reversed, the heat rejected exceeding that absorbed by the external work done.

The *Carnot cycle* would lead to a bulky machine. Actual air machines work with a *regenerator* or in the *Joule cycle*. In this latter, the low-temperature heat extracted from the body to be cooled is mechanically raised in temperature so that it may be carried away at a comparatively high temperature. The mechanical compression may occur in one or more stages.

The Joule cycle is bounded by two constant pressure lines and two like polytropics. If the latter are adiabatics,

$$W = Mk(T_b - T_c - T_a + T_d), \quad Q = Mk(T_c - T_d), \quad q = Mk(T_b - T_a).$$

The *displacement* per stroke of a double-acting compressor is $MRT_c \div 2NP_c$; that of the engine is $MRT_d \div 2NP_d$; the two displacements ordinarily have the ratio

$$\frac{T_c}{T_d}. \quad \text{These are to be modified for clearance, etc.}$$

Open type air machines work between pressures of 14.7 and 70 to 85 lb.; "*dense air machines*" between 65 and 225 lb., using closed circulation and, in some cases, a regenerator.

Coefficient of performance = $\frac{Q_c}{W}$; its value usually exceeds unity; the temperature range should be low. Value for Joule cycle = $\frac{T_a}{T_a - T_a'} = \frac{T_c}{T_b - T_c}$, if paths are adiabatic.

The *Kelvin warming machine* works in the Joule cycle and delivers heat proportional to the work expended in the ratio $\frac{T_a}{T_a - T_a'} = \frac{T_b}{T_b - T_c}$, which may greatly exceed unity.

The *vapor compression machine* uses no expansion cylinder. Refrigeration results from evaporation, but is reduced by the excess liquid heat carried to the cold chamber.

The *vaporizer* is the body to be cooled; the *condenser* removes the heat to be rejected; the *compressor* mechanically raises the temperature without the addition of heat; cooling of the fluid occurs during its passage through the *expansion valve*.

The path through the expansion valve is one of constant total heat; otherwise, the cycle is ideally that of *Clausius*.

$Q = xl - (H - h)$, $q = XL$, $W = XL + H - h - xl$, for vapor wet throughout, compression.

The vapor may be wet, dry, or superheated at the beginning of compression.

The *fluid used* should be one having a large latent heat and small specific heat. NH_3 , SO_2 , and CO_2 are those principally employed. N_2O is used for very low temperatures.

Capacity = ice-melting effect in tons per 24 hours = $\frac{Q \text{ per 24 hours}}{142 \times 2000}$, corrected for superheating.

Economy = ice-melting effect per pound of coal per Ihp.-hr.

Calculations of economy, capacity, and dimensions must include the corrective factor $\left(1 - 0.04 \frac{P}{P'}\right)$.

The *absorption machine* replaces the compressor by the *absorber* and the *generator*.

For low vaporizer temperatures it is theoretically superior to the compression apparatus. The absorption apparatus should give an efficiency equal to that in a non-condensing engine-driven compression system when the vaporizer temperature is 5° , and to that in a condensing engine system when it is 0° . Computation of heat balance.

Refrigeration may be *indirect*, by *direct expansion* or by *brine circulation*.

In *ice making* the can system is more rapid and occupies less space, while costing less, than the stationary cell or plate system. Clear ice is produced by using distilled water and as high a temperature as possible. An economical compressor engine is unnecessary. The pressure range is usually from 30 to 205 lb. The actual ice production is about one half the "ice-melting capacity."

The *A. S. M. E. basis* for rating machines is at temperatures of 0° and 90° F.

Usual *piston displacements* are from 6500 to 8700 cu. in. per minute per ton of rated capacity; engine *power rates*, from 1 to 2 Ihp. per ton.

Efficiency from engine cylinder to cooling room = $0.0557 \times$ ice-melting effect per Ihp.-hr.

Efficiency from coal to cooling room = $0.01015 \times$ ice-melting effect per pound of coal (14,000 B. t. u.).

Usual efficiencies from coal to cooling room, with vapor machines, range from 0.100 to 0.469, the average in good tests being about 0.237; say $23\frac{1}{2}$ lb. of ice-melting effect per pound of coal. Absorption machines have not shown efficiencies quite as high; those of air machines are extremely low.

PROPERTIES OF DRY SATURATED AMMONIA

(Condensed from Zeuner's *Technical Thermodynamics*, Klein Ed., by permission of D. Van Nostrand Co.)

T	P	V	h	L	H	r	n_w	n_e	n_s	T
- 22	16.912	15.956	- 47.88	593.8	545.92	543.6	- 0.1029	1.3576	1.2547	- 22
- 13	21.456	12.707	- 40.84	590.4	549.56	539.3	- 0.0870	1.3225	1.2355	- 13
- 4	27.030	10.306	- 33.43	586.4	552.97	534.8	- 0.0706	1.2879	1.2173	- 4
5	33.667	8.390	- 25.63	582.1	556.47	529.7	- 0.0536	1.2536	1.2000	5
14	41.571	6.888	- 17.46	577.4	559.94	524.3	- 0.0362	1.2198	1.1836	14
23	50.904	5.699	- 8.93	572.4	563.47	518.6	- 0.0183	1.1864	1.1681	23
32	61.836	4.709	0	557.5	557.50	503.8	0	1.1344	1.1344	32
41	74.539	3.933	10.12	548.5	558.62	494.6	0.0203	1.0943	1.1146	41
50	89.195	3.300	20.30	537.5	557.80	483.5	0.0405	1.0544	1.0949	50
59	105.974	2.787	30.60	526.7	557.30	472.5	0.0660	1.0132	1.0792	59
68	125.056	2.371	41.04	515.9	556.94	461.7	0.0804	0.9741	1.0545	68
77	146.612	2.026	51.48	503.8	555.28	449.6	0.1001	0.9359	1.0360	77
86	170.807	1.738	62.10	490.5	552.60	436.5	0.1196	0.8984	1.0180	86
95	197.796	1.493	72.72	474.8	547.52	421.2	0.1391	0.8636	1.0027	95
104	227.727	1.296	83.48	461.9	545.38	408.4	0.1583	0.8252	0.9837	104

For explanation of symbols, see Art. 420.

PROPERTIES OF DRY SATURATED CARBON DIOXIDE

(Condensed from Zeuner's *Technical Thermodynamics*, Klein Ed., by permission of D. Van Nostrand Co.)

T	P	h	Z	H	r	n_w	n_e	n_s	V	Specific Volume of the Liquid	T
- 22	213	- 24.80	126.72	101.92	110.25	- 0.053	0.290	0.236	0.432	0.0155	- 22
- 13	249	- 21.06	123.25	102.19	107.00	- 0.045	0.276	0.231	0.367	0.0157	- 13
- 4	289	- 17.19	119.43	102.21	103.46	- 0.036	0.262	0.226	0.312	0.0160	- 4
5	334	- 13.18	115.25	102.07	99.64	- 0.028	0.248	0.221	0.267	0.0163	5
14	385	- 9.00	110.65	101.65	95.49	- 0.019	0.234	0.215	0.228	0.0167	14
23	441	- 4.63	105.53	100.90	90.91	- 0.010	0.219	0.209	0.195	0.0171	23
32	504	0	99.81	99.81	85.84	0	0.203	0.203	0.167	0.0176	32
41	573	4.93	93.35	98.28	80.14	0.010	0.187	0.197	0.143	0.0181	41
50	650	10.28	85.93	96.21	73.65	0.021	0.169	0.189	0.120	0.0187	50
59	734	16.22	77.20	93.42	66.06	0.032	0.149	0.181	0.101	0.0197	59
68	826	23.08	66.47	89.55	56.80	0.045	0.126	0.171	0.083	0.0210	68
77	930	31.63	52.16	83.79	44.49	0.061	0.097	0.159	0.067	0.0227	77
86	1040	45.45	27.00	72.45	23.00	0.087	0.050	0.136	0.048	0.0268	86
87.8	1062	51.61	15.12	66.73	12.87	0.098	0.028	0.126	0.042	0.0298	87.8
88.43	1071	59.24	0	59.24	0	0.112	0	0.112	0.035	0.0346	88.43

For explanation of symbols, see Art. 420.

PROPERTIES OF DRY SATURATED SULPHUR DIOXIDE

(Condensed from Zeuner's *Technical Thermodynamics*, Klein Ed., by permission of D. Van Nostrand Co.)

T	P	V	h	L	H	r	n_w	n_e	n_s	T
- 22	5.564	12.720	-- 16.075	172.597	155.922	159.419	-- 0.0359	0.3946	0.3589	- 22
- 13	7.228	10.074	-- 13.957	171.950	157.993	158.396	-- 0.0298	0.3852	0.3554	- 13
- 4	9.272	8.051	-- 11.216	171.000	159.784	157.111	-- 0.0237	0.3755	0.3518	- 4
5	11.756	6.486	-- 8.449	169.745	161.296	155.563	-- 0.0177	0.3655	0.3478	5
14	14.745	5.265	-- 5.657	168.187	162.530	153.753	-- 0.0117	0.3553	0.3436	14
23	18.311	4.304	-- 2.842	166.325	163.483	151.680	-- 0.0058	0.3448	0.3390	23
32	22.530	3.540	0	164.160	164.160	149.346	0	0.3341	0.3341	32
41	27.483	2.930	2.866	161.690	164.556	146.748	0.0058	0.3231	0.3289	41
50	33.253	2.436	5.758	158.917	164.675	143.889	0.0115	0.3120	0.3235	50
59	39.931	2.037	8.674	155.840	164.514	140.767	0.0172	0.3006	0.3178	59
68	47.611	1.711	11.615	152.460	164.075	137.383	0.0228	0.2891	0.3119	68
77	56.386	1.445	14.582	148.775	163.357	133.718	0.0284	0.2773	0.3057	77
86	66.359	1.220	17.572	144.787	162.359	129.827	0.0339	0.2655	0.2994	86
95	77.630	1.036	20.588	140.495	161.083	125.656	0.0394	0.2534	0.2928	95
104	90.300	0.884	23.629	135.900	159.529	121.223	0.0448	0.2412	0.2860	104

For explanation of symbols, see Art. 420.

PROBLEMS

NOTE. Our knowledge of the properties of some of the vapors used in refrigeration is far from accurate. Any general conclusions drawn from the results of the problems are therefore to be regarded with caution. (See Art. 402.)

1. Plot to scale to PV coordinates a Carnot cycle for air in which $T = 80^\circ \text{ F.}$, $t = 0^\circ \text{ F.}$, and the extreme range of specific volumes is from 1 to 4. Compare its area with that of the Joule cycle between the same volume and pressure limits.

2. In a Bell-Coleman machine working between atmospheric and 73.5 lb. pressure, the temperature of the air at the condenser outlet is 80° , and that at the compressor inlet is 0° . Find the temperatures after expansion and after compression, the curves following the law $PV^{1.35} = c$.

3. Find the coefficient of performance for a Bell-Coleman machine with pressures and temperatures as given above, but with compression in two stages and intercooling to 80° . (The intermediate pressure stage to be determined as in Art. 211.) Compare with that of the single-stage apparatus.*

4. Compare the consumption of water for cooling in jackets and condenser and for intercooling, in the two cases suggested. (See Art. 234.)

5. The machine in Problem 2 is to handle 10,000 cu. ft. of free air at 32° F. per hour. Find the sizes of the double-acting expansion and compression cylinders ideally necessary at 100 r. p. m. and 400 ft. per minute piston speed.

6. What would be the sizes of compressive cylinders, under these conditions, if compression were in two stages?

7. Find the theoretical cylinder dimensions, power consumed, coefficient of performance, and cooling water consumption, for a single-stage, double-acting, dense air machine at 60 r. p. m., 300 ft. per minute piston speed, the pressures being 65 and 225 lb., the compressor inlet temperature 5° , the condenser outlet temperature of air 95° , and the circulating water rising from 65° to 80° . The apparatus is to make $\frac{1}{2}$ ton of ice per hour from water at 65° . The curves follow the law $pv^{1.35} = c$.

8. Find the theoretical coefficient of performance of a sulphur dioxide machine working between temperatures of 64.4° and 5° F. , the condition at the beginning of compression being, (a) dry, (b) 60 per cent dry. Also (c) if the substance is dry at the end of compression.

9. Check all values in Art. 632.

10. What is the theoretical ice-melting capacity of the machine in Problem 5?

11. Find the ice-melting capacity per horse power hour in Problem 7.

12. Find the results in Problem 7 for an ammonia machine working between 5° and 95° , the vapor being just dry at the end of adiabatic compression. How do the coefficients of performance in the two cases compare with those of the corresponding Carnot cycles?

13. What is the loss in Problem 2, if a brine circulation system is employed, requiring that the temperature at the compressor inlet be -25° F. ?

* The formula for coefficient of performance of the Joule cycle, given in Art. 622, will be found not to apply when the paths are not adiabatic.

14. In a Kelvin warming machine, the temperature limits for the engine are 300°F . and 110°F .; those for the warming cycle are 150°F . and 60°F . Assume that the cycles are those of Carnot, and introduce reasonable efficiency ratios, determining the probable efficiency (referred to power only) of the entire apparatus.

15. Compare the coefficient of performance in Problem 12 with those in which the vapor is (a) 80 per cent dry, (b) dry, as it leaves the vaporizer.

16. Find the coefficient of performance in Problem 15 (b) if the compressive path is $PV^{1.25} = c$. (Compare the Pambour cycle, Art. 413.)

17. Compare the ratio $\frac{\text{latent heat}}{\text{specific heat of liquid}}$ at 5° and 64.4°F . (Art. 632), for ammonia, carbon dioxide, and sulphur dioxide. Draw inferences.

18. Plot on the entropy diagram in Problem 12 the path of the substance through the expansion valve, determining five points.

19. Find the temperature at the generator discharge of an ammonia absorption machine, the liquid from the absorber being delivered at 110°F . and 30 lb. pressure, and the pressure of vapor leaving the generator being 198 lb.

20. An ammonia compression apparatus is required to make 200 tons of ice per 24 hr.; in addition it must cool 1,000,000 cu. ft. of air from 90° to 40° each hour by indirect refrigeration. Making allowances for practical imperfections, find the tonnage rating, cylinder dimensions, power consumed, cooling water consumption, and ice-melting effect per Ihp.-hr., the machine being double-acting, 70 r. p. m., 560 ft. per minute piston speed, operating between 33.67 and 198 lb. pressure with vapor dry at the end of adiabatic compression, water being available at 65° . Estimate whether the exhaust steam from the engine will provide sufficient water for ice making.

21. Make an estimate of the production of ice per pound of coal in a good plant.

22. What is the tonnage rating of the machine in Problem 20 on the A.S.M.E. basis?

23. Coal containing 13,500 B. t. u. per pound drives a simple non-condensing engine operating an ammonia compression apparatus. The ice-melting effect is 84 lb. per Ihp.-hr. at the engine cylinder. The coal consumption is 3 lb. per Ihp.-hr., and the mechanical efficiency of the combined engine and compressor is 0.80. Find the ice-melting effect per pound of coal, the coefficient of performance, the efficiency from fuel to engine cylinder, and the efficiency from fuel to refrigeration. May this last exceed unity?

24. An absorption apparatus gives an ice-melting effect of 1.8 lb. per pound of dry steam at 27 lb. pressure from feed water at 55°F . Prove that this performance may be excelled by a compression plant.

25. Find a relation between *coefficient of performance* and ice-melting effect per Ihp.-hr. at the compressor cylinder.

26. Find the tonnage on the A.S.M.E. standard basis of a 12×30 inch double-acting compressor at 60 r. p. m., using (a) ammonia, (b) carbon dioxide.

27. Find the A.S.M.E. tonnage rating for an ammonia absorption apparatus working between 30 and 182.83 lb. pressure with 10,000 lb. of dry vapor entering the generator per hour.

28. Check all derived values in Art. 660 to Art. 663.

29. Compare the coefficients of performance, in Art. 632 and in Problem 8, with those of the corresponding Carnot cycles.
30. Compute the value of X in Art. 658.
31. Compute as in Art. 632 the results for carbon dioxide. Why might not ether be included in a similar comparison?
32. Ether at 52° F. is compressed adiabatically to 232° F., becoming wholly liquid. What was its initial condition? (Fig. 315.)

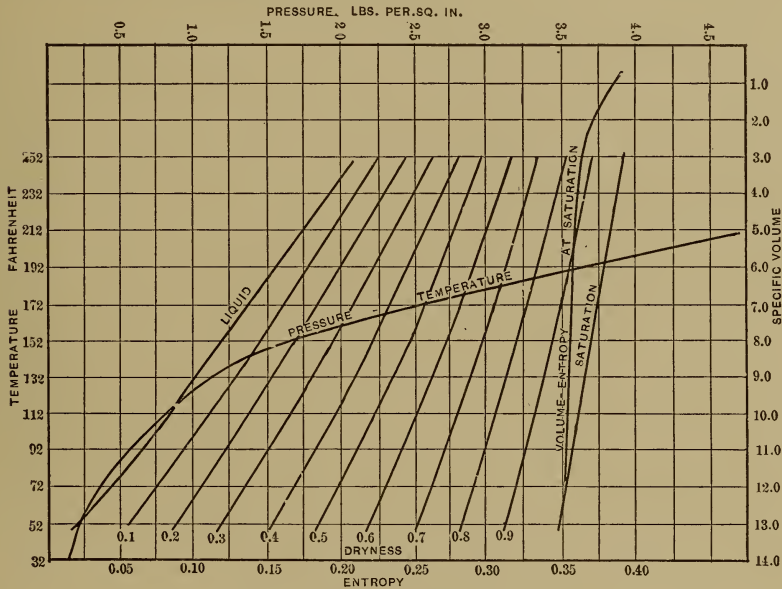

Fig. 315. — Entropy Chart for Ether.

33. Discuss variations with temperature of the *total heat* of ammonia, sulphur dioxide, carbon dioxide. (See tables, pp. 422-424.)
34. Plot a total-heat entropy diagram for carbon dioxide.
35. Find the ratio $\frac{\text{cubic inches of piston displacement per minute}}{\text{rated tonnage}}$ for the A.S.M.E. temperature limits, with vapor dry at the beginning of compression. (Art. 659.)
36. Find a general expression for the coefficient of performance in the Joule cycle, the paths *not* being adiabatic.
37. Discuss the economy and general desirability of using the exhaust steam from the engine driving an ammonia compressor, to distill *in vacuo* the water from which ice is to be made.

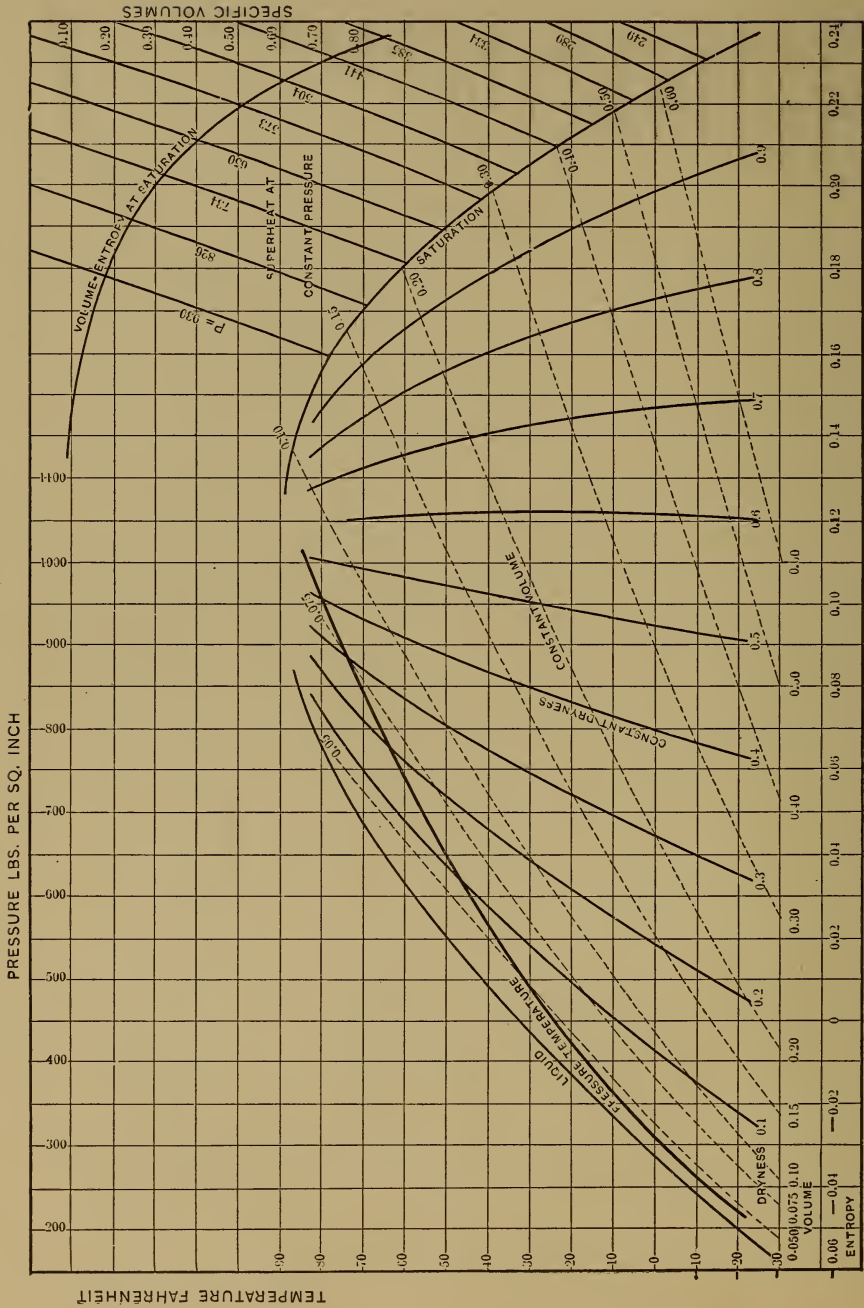

Fig. 314. — Entropy Chart for Carbon Dioxide. (Plotted with the constant value 0.20 for the specific heat of the superheated vapor.)

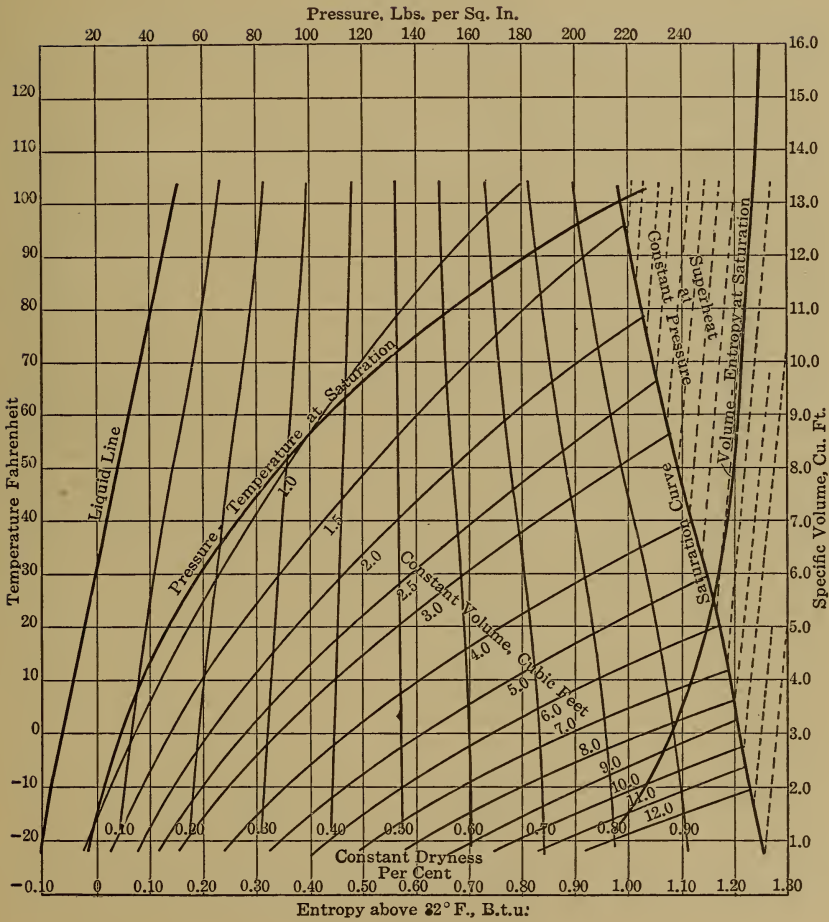

FIG. 316. — Entropy Chart for Ammonia.

INDEX

(Referring to Art. Nos.)

- Absolute humidity, 382c.
Absolute temperature, 152-156, 167.
Absolute zero, 44, 45, 156.
Absorption refrigerating machine, 639-643.
Accumulator, 541.
Adiabatic, 83, 100-105, 168, 173, 176, 325.
Adiabatic expansion of steam, 372, 373, 416, 431a, 432, 513, 515, 517-520.
 of mixture, 382f, 382h.
 specific heat variable, 329a.
Adiabatics of vapors, 391-397.
Afterburning, 325.
Aftercooler, 208.
Air, Carnot cycle for, 249.
 free, 233.
 moisture in, 182, 208; page 246.
 liquid, 246, 355, 609-610.
 saturated, 382c.
 in solutions, 591.
 specific heat, 71, 72.
Air compressor, 193-212, 215, 216, 221-242, 540.
Air cooling in compressor, 199.
Air engine, 177, 180-192, 245, 254.
Air refrigerating machine, 227, 612-620, 661.
Air-steam mixture, 382c, 382f, 382g.
Air supply, boiler furnace, 560, 563-567, 573, 575.
 gas engine, 309.
Air thermometer, 41, 42, 48, 49, 152.
Air transmission, 243, 245.
Alcohol engine, 279, 280, 341.
Alcohol thermometer, 7.
Altitude, 52a.
Ammonia, 403, 606, 630-632, 640, 644, Table, p. 486, Fig. 316.
Ammonia absorption machine, 639-643, 663.
Analysis of producer gas, 285.
Andrews' critical temperature, 379, 380, 605, 607.
Anthracite coal, 560.
Apparent ratio of expansion, 450.
Apparent specific heat, 61.
Atkinson gas engine, 276, 296, 297.
Atmosphere, pressure of, 52a.
Atmospheric condenser, 664.
Atomic heat, 59.
Automatic engine, 507.
Automatic ignition, 322.
Automobile engine, 335, 340, 348.
 self-starter, 351.
Auxiliaries, gas producer, 281.
Avogadro's principle, 40, 53, 56.
Back pressure, 405a, 448, 459, 549h.
Ballonet, 52a.
Balloon, 52a.
Barometric condenser, 584.
Barrel calorimeter, 489.
Bell-Coleman refrigerating machine, 613-620, 661.
Bicycle, motor, 340.
Binary vapor engine, 483.
Blading, turbine, 530, 535.
Blast furnace gas, 276, 278, 329, 353.
Blowing engine, 179, 211, 239.
Boiler, 143, 566, 568-573.
Boiler efficiency, 569, 571-573.
Boiler horse-power, 570.
Boiling points of ammonia solutions, 640.
Boulvin's method, 455, 456.
Boyle's law, 38, 39, 84.
Brake horse power, 554.
Brauer's method, 117.
Brayton cycle, 299, 300, 302, 304.
Brine, 646, 657.
Brine circulation, 645-647.
British thermal unit, 22.
Bucket, 512, 527-530.
Calcium chloride brine, 646.
Caloric theory, 2, 131.
Calorie, 23.
Calorimeter, 488-494.
Calorimeter testing of steam engine, 504, 505, 511.
Capacity, air compressor, 222-229, 230-237.
 air engine, 182, 183, 188, 190.
 air refrigerating machine, 616, 618, 619.
 compound steam engine, 476-477.
 gas engine, 277, 330.
 hot-air engine, 248, 249, 275, 277.
 Otto-cycle gas engine, 293.
 steam cycles, 418.
 steam engine, 445, 447, 449.
 vapor compressor, 633, 636, 637.

- Carbon dioxide, 379, 402, 605-608, 611, 630-632, 637, Fig. 314, Table, p. 487.
- Carbon monoxide, 565.
- Carbon tetrachloride, 382*h*.
- Carbureted air, 279.
- Carburetor, 279, 282, 310, 336.
- Cardinal property, 10, 76, 81, 88, 160, 162, 169, 176, 370, 399.
- Carnot, 28, 130.
- Carnot cycle, 128-143, 253, 451.
 air engine, 250.
 entropy diagram, 159, 166.
 for air, 249.
 for steam, 406.
 reversed, 138, 612, 621.
- Carnot function, 155.
- Cascade system, 603.
- Centigrade heat unit, 23.
- Centigrade thermometer, 8.
- Change of state, 15-18.
- Characteristic equation, 10, 50, 84, 302, 390, 401, 403, 404.
- Characteristic surface, 84.
- Characteristic symbols, p. xiii.
- Charles' law, 41-49, 84.
- Chimney, 575.
- Circulation in steam boiler, 569.
- Clapeyron's equation, 368.
- Clausius cycle, 408, 410, 447, 514.
- Clausius ratio, 127*a*.
- Clearance, 188.
 air compressor, 222, 223.
 gas engine, 295, 313, 324.
 steam engine, 450, 451, 462, 471, 549*l*.
 vapor compressor, 616, 618.
- Clerk's gas engine, 300, 303-305.
- Closed feed-water heater, 581.
- Closed hot-air engine, 248, 275.
- Coal, 560, 578.
- Coal gas, 276, 278, 329.
- Coefficient of performance, 621, 622, 628.
- Coil calorimeter, 490.
- Combined diagrams, 466-468, 475-479.
- Combustion, 127*b*, 560, 561, 563-567, 569, 573, 575.
 surface, 569.
- Complete pressure gas engine cycle, 300, 303-305.
- Compound steam engine, 438, 459-483, 510, 548*a*, 548*b*, 550.
- Compound locomotive, 510.
- Compressed air, 177-247.
 distributing system, 212-221.
 refrigeration by, 227.
 storage system, 185, 245.
 transmission, 243-245.
 uses, 177, 178.
- Compression, in air compressor, 105-211.
 air engine, 189, 191.
 Carnot cycle, 132, 134.
 gas engine, 276, 295, 297, 299, 312, 313, 325, 348.
- Compression, steam engine, 451, 462, 549*l*.
- Compressive efficiency, 213.
- Compressor, air, 193-212, 215, 216, 221-242, 540.
 vapor, 624-638, 642, 658, 660, 662, 664.
- Condensation in steam cylinder, 428-443, 448, 460.
- Condenser, 496, 502, 584, 585, 591, 617, 635, 664.
- Condenser pumps, 584.
- Constant dryness curve, 369.
- Constant heat curve, 370, 398.
- Constant volume curve, 377.
- Constant weight curve, 365.
- Constrained expansion, 124.
- Cooling of gas engine cylinder, 312, 314-318, 325.
- Cooling pond, 585.
- Cooling tower, 585, 664.
- Cooling water in refrigerating plant, 617, 635.
- Coordinate diagrams, 81-127, 158.
- Criterion of reversibility, 139-141, 144-149.
- Critical temperature, 379, 380, 605, 607.
- Cross-compound steam engine, 464, 477, 478.
- Curtis steam turbine, 524, 531, 537.
- Cushion air, 262, 264.
- Cushion steam, 453, 457*a*, 575.
- Cycle, Carnot, 128-143, 253, 451.
- Cycle, external work, 89.
 forms, 130.
 heat engine, 129.
 heat expended in, 90.
 regenerative, 259.
 reversed, 90.
 reversible, 138-141, 147, 148, 152, 175, 176.
- Cycles, air:
 air compressor, 194-211.
 air engine, 180-183.
 air refrigeration, 615.
 air system, 218-221.
 Bell-Coleman, 615.
 Eriasson, 270.
 hot-air engine, 256.
 Joule, 254, 255, 613, 622.
 Lorenz, 252.
 polytropic, 251.
 regenerative air engine, 259.
 Reitlinger, 253, 259.
 Stirling, 264.
- Cycles, gas, 276, 287-308, 329*a*.
 Brayton, 299.
 Clerk, 300, 303-305.
 complete pressure, 300, 303-305.
 Diesel, 306, 307, 307*b*.
 Frith, 295*b*.
 Lenoir, 298, 300, 301, 304.
 Otto, 276, 287-297, 300, 309-329, 329*a*.
 Sargent, 295*a*.
 two-stroke, 289-292, 329.

- Cycles, refrigerative:
 air machine, 254, 255, 613, 615, 622.
 regenerative, 259, 610, 612.
 vapor machine, 627.
- Cycles, steam, 417, 418, 422-458, 544.
 binary, 483.
 Clausius, 408-410, 417, 447, 514.
 non-expansive, 412, 417, 423.
 Pambour, 413, 417.
 Rankine, 411, 417, 424, 429, 447, 544.
 regenerative, 544.
 superheated, 414-418, 544.
 turbine, 514.
- Cylinder condensation, 428-444, 447, 460.
 Cylinder efficiency, 212, 215, 216, 229.
 Cylinder feed, 453, 466.
 Cylinder ratios, 474, 480, 543*a*, 549*n*.
 Cylinder walls, 429, 431*a*, 432, 504, 505.
 vapor compressor, 637.
- Dalton's law, 40, 52*b*, 382*b*.
 Davis' method for determining *H*, 360, 388.
 De Laval steam turbine, 512, 524, 530, 536.
 Dense air refrigerating machine, 620.
 Design of compound engine, 469-472.
 Desormes' apparatus, 110.
 Development of steam engine, 543*a*.
 Diagram, coordinate, 81-127, 158.
 entropy, 158-160, 164, 166, 169-171, 174, 184, 218-221, 255, 266, 295*a*, 295*b*, 307, 347, 367, 376-378, 398, 453-458, 615, 627.
 indicator, 437, 452, 454, 486-487, 500, 501.
 indicator, gas engine, 311.
 Mollier, 399, 516, 532.
 of energy, 86-90.
 temperature-entropy, 158-160, 164, 166, 169-171, 174, 184, 218-221, 255, 266, 295*a*, 295*b*, 307, 347, 367, 376-378, 398, 453-458, 615, 627.
 total heat entropy, 399, 516, 532.
 total heat-pressure, 399.
 velocity, 527-529, 534.
- Diagram factor, 329, 334, 445, 466, 633.
 Diesel engine, 306, 307, 307*b*.
 Difference of specific heats, 65, 67, 77, 165.
 Diffusion of gases, 127*b*.
 Direct expansion, 644.
 Disgregation work, 3, 12, 15-17, 53, 56, 64, 75, 76, 78, 80, 359, 360.
 Dissipation of energy, 176.
 Dissipation of gases, 127*b*.
 Dissociation, 63, 127*b*, 318, 325.
 Distillation, 591-601.
 Distribution of work, compound steam cylinders, 469-472.
 Double-acting engine, 423.
 Down-draft furnace, 578.
 Draft, 560, 567, 570, 575-577, 582.
 Drop, 181, 436, 447, 465, 467, 468, 479.
- Dry compression, 629, 647.
 Dry vacuum pump, 237, 584.
 Dryness curve, 369.
 Duplex compressor, 239.
 Duty, 503.
- Economizer, 282, 582.
 Effects of heat, 12-17.
 Efficiency, air engine, 180, 185, 190, 192.
 boiler, 569, 571-573.
 Brayton cycle, 299.
 Carnot cycle, 135, 136, 142, 166.
 Clausius cycle, 409.
 compressed air system, 212-217.
 compressive, 213.
 Diesel engine, 307, 307*b*.
 Ericsson engine, 248, 249, 269-273.
 Frith engine, 295*b*.
 gas engine, 295, 295*a*, 295*b*, 308*a*, 329*a*, 334, 342-346.
 gas producer, 284-286.
 heat engine, 128, 142, 143, 149.
 Humphrey pump, 308*a*.
 injector, 588, 590.
 Joule air engine, 235.
 Lenoir cycle, 298, 301.
 mechanical, 212, 214, 216, 342, 345, 487, 503, 511, 553-558.
 multiple-effect evaporation, 599.
 non-expansive cycle, 412.
 nozzle, 518.
 Otto gas engine, 295-297, 300, 329*a*.
 Pambour cycle, 413, 417.
 plant, 503.
 Rankine cycle, 411, 544.
 ratio, 544, 551.
 refrigerating machine, 621, 622, 634, 642, 661-663.
 refrigerating plant, 621, 622, 628.
 regenerative steam cycle, 544.
 Sargent cycle, 295*a*.
 steam engine, 496, 543*a*, 545-549*o*, 551.
 steam turbine, 526, 529, 552.
 Stirling engine, 265, 267, 268.
 superheated cycles, 415, 544.
 thermal, 342, 496.
 transmissive, 212-216, 243, 244.
 volumetric, 222-229, 233.
- Ejector, 587.
 Electrical ignition, 323.
 Electrical resistance pyrometer, 9.
 Electric calorimeter, 494.
 Energy, 10, 12, 76-78, 81, 100, 109, 113, 119-123, 359, 374, 375, 382*d*.
 Engine, air, 177, 180-192, 245.
 binary vapor, 483.
 blowing, 179, 211, 239.
 Clerk's, 300, 303-305.
 Diesel, 306-307, 307*b*.
 Frith, 295*b*.
 gas, 248, 276, 277, 287-308, 312, 313, 324, 325, 329*a*, 330, 348.

- Engine, heat, 128, 130, 132, 139, 142, 143.
 hot-air, 248-275, 277.
 internal combustion, 248, 276, 277, 287-308, 329*a*.
 Joule, 235, 254.
 for mixed vapors, 382*i*.
 oil, 276, 279, 280, 299.
 rotary steam, 177, 192.
 Sargent, 295*a*.
 for special vapors, 405*a*.
 steam, 143, 408-419, 422-511, 514, 543*a*, 550.
 turbine, 239, 512-542, 555.
 Engineering vapors, 402.
 Entropy, 10, 157-176.
 formulas, 169.
 gases, 169.
 mixtures, 169*a*, 382*i*-382*h*.
 physical significance, 160.
 specific heats variable, 329*b*.
 units, 171.
 Entropy diagram, 158, 174.
 air engine, 184.
 Bell-Coleman machine, 615.
 Carnot cycle, 159, 166.
 compressed air system, 218-221.
 Diesel engine, 307, 307*b*.
 Frith cycle, 295*b*.
 gas engine, 347.
 Joule engine, 255.
 Sargent cycle, 295*a*.
 specific heats of gases, 164.
 steam, 398.
 steam engine, 453-458.
 steam formation, 367, 376-378.
 Stirling engine, 266.
 vapor refrigeration, 627.
 Equalization of work, 469-472.
 Equation, characteristic, 10, 50, 84, 363, 390, 401, 403, 404.
 of condition, 10, 50, 84, 363, 390, 401, 403, 404.
 Equation of flow, 522.
 Equivalent evaporation, 361, 367, 386, 572.
 Equivalent simple engine, 473.
 Ericsson hot-air engine, 270.
 Ether, 371, 372, 402, 483, 611, 631, 663, Fig. 315.
 Evaporation, factor of, 361, 367, 389, 572.
 latent heat of, 359, 360.
 rate of, 569.
 in vacuo, 691-601.
 Evaporative condenser, 585.
 Evaporator, 593, 595, 600, 601.
 Exhaust gas heat, 346.
 Exhaust line, gas engine diagram, 326.
 Exhaust steam injector, 589.
 Exhaust steam turbine, 540, 541, 552.
 Expansion, constrained, 124.
 direct, 644.
 Expansion, free, 73, 75, 79, 124-127, 513, 515, 517, 607, 610, 613.
 Expansion, latent heat of, 58, 107.
 regenerative, 610, 612.
 steam cylinder, 428-447, 450, 479, 486, 557.
 steam turbine, 513, 515, 517.
 Expansion curve, gas engine, 325.
 Explosion waves, 319, 325.
 Exponential equation, 391, 394, 395; pp. 71, 72.
 External work, 14, 15, 86-90, 95, 98, 121-123, 160, 359, 374, 375.
 Externally fired boiler, 568.
 Factor, heat, 170.
 Factor of effect, 123*a*.
 Factor of evaporation, 361, 367, 389, 572.
 Feed pump, 586.
 Feed-water heater, 580-582.
 Figure of merit, 286.
 Fire-tube boiler, 568, 569.
 First law of thermodynamics, 28-37, 79, 128, 167, 505.
 Fixed point, 6, 16, 18.
 Flame propagation, 309, 310, 319, 320, 325.
 Flow, equation of, 522.
 in nozzle, 518, 521-523.
 in orifice, 523.
 Fluid friction, 326, 342.
 Forced draft, 570, 577.
 Formation of steam, 354-360, 366, 381, 386.
 Free air, 233.
 Free expansion, 73, 75, 79, 124-127, 513, 515, 517, 607, 610, 613.
 Freezing mixtures, 15, 611.
 Friction, fluid, 326, 342, 518.
 in Joule's experiment, 76, 127.
 in nozzles, 518-520, 523.
 in steam engine, 554-558.
 in turbine buckets, 527.
 Frith cycle, 295*b*.
 Fuel oil, 280.
 Fuels, 560, 561.
 Function, Carnot's, 155.
 thermodynamic, 170.
 Furnace for soft coal, 578.
 Fusion, 602-604.
 Gas, coal, 276, 278, 329.
 liquefaction of, 605-610.
 monatomic, 127*a*.
 natural, 276, 278, 329.
 oil, 279.
 perfect, 39, 50, 51, 53, 56, 74, 80, 607.
 permanent, 16, 63, 605.
 polyatomic, 127*a*, 127*b*.
 producer, 276-286, 312, 329.
 steam, 357, 390, 391.
 water, 278, 281, 329.
 Gas engine, 248, 276, 277, 287-308, 308*a*, 312, 313, 324, 325, 329*a*, 330, 348.
 Clerk's, 300, 303-305.
 Gas-engine design, 330-335.

- Gasoline, 279, 280.
 Gas power, 276-353.
 Gas producer, 276-286.
 Gas producer auxiliaries, 281.
 Gas transmission, 276.
 Gas turbine, 540.
 Gas-vapor mixtures, 382*b*-382*i*.
 Gases, dissipation of, 127*a*.
 diffusion of, 127*b*.
 Gases, kinetic theory, 53-56, 80.
 mixtures of, 52*b*.
 properties of, 52, 63.
 Gay-Lussac's law, 41-49.
 Goss evaporator, 601.
 Governing, air compressor, 238.
 gas engine, 290, 336-338, 348, 349.
 steam engine, 462, 468, 478, 505*a*.
 Gram-calorie, 23.
 Grate area, 284, 569.
 Gravity return drip system, 583.
 Guarantees, steam engine performance, 549*o*.
 Gunpowder, 123*a*.
- H*, 359, 360, 388.
 Heat absorbed, graphical representation, 106, 123, 167.
 Heat, mechanical theory, 2-5.
 Heat balance, 345, 346, 496.
 Heat of combustion, 127*b*, 561*a*.
 Heat consumption, 544.
 Heat drop, 515-519.
 Heat engine, 128, 130, 132, 139, 142, 143.
 Heater, feed-water, 580-582.
 Heat factor, 170.
 Heat of formation, 561*a*.
 Heat of liquid, 359.
 Heat unit, 20-23.
 Heat value, 561, 561*a*.
 Heat weight, 170, 172.
 Heating surface, 569.
 High-speed steam engine, 434, 507.
 High steam pressure, 143, 444, 459, 462.
 Hirn, 32.
 Hirn's analysis, 504, 505, 511.
 Hit-or-miss governing, 349.
 Horse power, boiler, 570.
 brake, 554.
 Hot-air engine, 248-275, 277.
 Hot-air jacket, 439.
 Hot-tube ignition, 322, 336, 337.
 Humidity, 382*c*.
 Humphrey pump, 308*a*.
 Hydraulic compressor, 241.
 Hydraulic piston compressor, 240.
 Hydrogen, 60, 355, 609.
 in producer gas, 284, 285, 312.
 Hygrometry, 382 *c*.
 Hyperbolic curve, 444, 450, 479, 486.
 Hyperbolic functions, p. 71.
- Ice, 2, 85, 602-604.
 Ice making, 652-657.
 Ice-melting effect, 634.
 Ignition, 105*a*, 314-323, 325, 336, 337.
 Impulse turbine, 524, 530-533, 536-538.
 Incomplete expansion, 181, 436, 447, 465, 467, 468.
 Indicated thermal efficiency, 342.
 Indicator, 424, 484-485.
 Indicator diagram, 437, 452, 454, 486-487, 500-501.
 gas engine, 311.
 Indirect refrigeration, 648.
 Induced draft, 577.
 Initial condensation, 430, 433, 436, 437, 442, 448, 460.
 formula for, 437.
 Injector, 587-590.
 Injection of water, 195, 200.
 Injector condenser, 584.
 Intercooler, 206, 207.
 Intermediate compound, 474, 480, 549*n*.
 Internal combustion engine, 248, 276, 277, 287-308, 308*a*, 329*a*.
 Internal combustion pump, 308*a*.
 Internal energy, 10, 12, 76-78, 81, 100, 109, 113, 119-123, 359, 374, 375, 382*d*-382*h*.
 Internal work of vaporization, 359, 360.
 Internally fired boiler, 568, 569.
 Inversion, 373, 395, 401.
 Irreversibility, 11, 73-76, 78, 175, 176.
 Irreversible process, 124-127, 160, 426, 513.
 Isentropic, 168, 176.
 Isodiabatic, 108, 112.
 Isodynamic, 83, 96, 120-122.
 Isodynamic vapor, 382.
 Isoenergetic, 83, 96, 120-122, 382.
 Isometric, 83.
 Isopiestic, 83.
 Isothermal, 78, 83, 91-95, 122, 366, 382*f*.
- Jacket, gas engine, 352, 353.
 hot-air, 439.
 steam, 413, 438-441, 466, 482, 505, 549*b*, 549*m*.
 vapor compressor, 635.
 Jet condenser, 496, 502, 584.
 Joule air engine, 254.
 Joule apparatus, 2, 30.
 Joule cycle, 254, 255, 613, 622.
 Joule experiment, 73-80, 124-127, 156, 176.
 Joule's law, 75-80, 109.
 Junkers engine, 307*b*.
- Kelvin scale of absolute temperature, 153-156, 167.
 Kelvin warming machine, 623.
 Kerosene, 279, 280, 310.
 Kinetic theory of gases, 53-56, 80, 127*a*, 127*b*.

- Kirk air refrigerating machine, 612.
Knoblauch and Jakob, 384.
- Lagging, 439.
Latent heat of expansion, 58, 107.
 of fusion, 602-604.
 of evaporation, 359, 360.
Leakage, 431*b*, 452, 549*k*.
Lenoir cycle, 298, 300, 301, 304.
Linde apparatus, 246, 610.
Line of inversion, 373.
Liquefaction of gases, 605-610.
 of steam during expansion, 372, 373, 431*a*, 432.
Liquid air, 246, 355, 609, 610.
Liquids, mixtures, 169*a*.
Locomotive boiler, 568.
 superheater, 443, 509, 553.
 tests, 497, 511, 533.
 theory, 509.
 turbo-, 540.
 types, 509, 510.
Logarithms, pp. 71, 72.
Logarithmic diagram, 431*b*, 446.
Loop, steam, 583.
Lorenz cycle, 252.
Losses in steam boiler, 566.
 in steam turbine, 514.
- Mariotte's law, 38, 39.
Marine boiler, 568.
Marine turbine, 540.
Mathematical thermodynamic method, 400, 401.
Mayer, 29, 72.
Mayer's principle, 94.
Mean effective pressure, 329, 331, 445, 471, 486.
Mean specific heat, 61, 164.
Mechanical draft, 576, 582.
Mechanical efficiency, 212, 214, 216, 487, 503, 511, 553-558.
 gas engine, 342, 345.
Mechanical equivalent of heat, 2, 28-37, 79, 505.
Mechanical theory of heat, 2-5.
Mercurial thermometer, 7.
Metallic pyrometer, 9.
Mixtures, 20, 21, 25.
 air and moisture, 182, 208, 382*a*.
 expansion of, 382*d*-382*f*, 382*h*.
 entropy of, 169*a*, 382*d*-382*h*.
 freezing, 15, 611.
 gas and vapor, 52*b*, 382*b*-382*i*.
 in gas engine, 309, 310, 321, 348.
 in heat engines, 382*i*.
 internal energy of, 382*d*-382*h*.
 liquids, 169*a*.
 steam and air, 382*c*, 382*f*, 382*g*.
 specific heat, 382*c*.
Moisture in air, 182, 208, 382*a*.
 in steam, 549*f*.
- Molecular heat, 59.
Mollier diagram, 399, 516, 532.
Monatomic gas, 127*a*.
Mond gas, 278, 283.
Motor-bicycle, 340.
Multiple-effect evaporization, 594-601.
Multiple expansion, 438, 459-483, 510, 548*a*, 548*b*, 549*n*, 550.
Multi-stage air compression, 205-211, 221, 226, 232, 234, 235, 239.
Multi-stage vapor compression, 629.
- n*, 91, 97, 115-118, 164, 329*b*, 382*f*, 431*b*, 446.
- Natural gas, 276, 278, 329.
Negative specific heat, 115, 371.
Negative work, 87, 89, 99.
Neutrals, 319, 320.
Newhall evaporator, 593.
Nitrous oxide, 631.
Non-expansive cycle, 412, 423.
Nozzle, 512-515, 518-523, 525.
- Oil engine, 276, 279, 280, 299, 306, 307.
Oil fuel, 280.
Oil gas, 279.
Open feed-water heater, 581.
Opposed beam engine, 464*a*.
Optical pyrometer, 9.
Ordnance, 123*a*.
Orifice, 523.
Osmosis, 127*b*.
Otto cycle, 276, 287-297, 300, 309-329, 329*a*.
Overload capacity, gas engine, 330, 333.
 steam engine, 447.
Oxygen, 606, 608, 609.
- Pambour cycle, 413.
Parsons turbine, 524, 533, 539, 555.
Path, 83, 85, 88, 97-99, 111-118.
Paths of vapors, 392-399.
Paths of mixtures, 382*d*, 382*e*.
Pelton bucket, 529.
Perfect gas, 39, 50, 51, 53, 56, 74, 80, 607.
Permanent gas, 16, 63, 605.
Petletole evaporator, 601.
Pictet apparatus, 608.
Pictet fluid, 631.
Piston speeds, gas engine, 320.
 steam engine, 445.
Plant efficiency, 503.
Pneumatic tools, 178.
Polyatomic gas, 127*a*, 127*b*.
Polytropic cycle, 251.
Polytropic paths, 97-99, 111-118, 125, 161, 164, 165.
Pond, cooling, 585.
Porous plug experiment, 73-80, 124-127, 156, 176.
Power plant, steam, 407, 408, 560-590.

- Preheater, 186, 187.
 Pressure in gun, 123*a*.
 Pressure, high steam, 143, 444, 459, 462, 549*e*.
 Pressure in internal combustion engines, 316.
 Pressure-temperature relation, 355, 358, 362, 368, 382*a*.
 Pressure turbine, 524, 533-535, 539.
 Problems, pages, 10, 17-18, 30-31, 41-42, 73-75, 82-83, 89-91, 104-105, 143-144, 160-161, 226-229, 292-297, 358-362, 395-396, 413-414, 436-438, 452-453, 489-491.
 Producer, 276-286.
 Producer gas, 276-286, 312, 329.
 Projectile, 123*a*.
 Propagation of flame, 105*a*, 309, 310, 316, 319, 320, 325.
 Properties of gases, 52, 63.
 Properties of steam, 360, 367, 376, 405, 420, 421.
 Pump, feed, 586.
 condenser, 584.
 internal combustion, 308*a*.
 turbo-, 540.
 vacuum, 236, 237, 584, 591.
 Pyrometer, 9.
- Quadruple expansion engine, 461, 543*a*, 550.
- R*, 51, 52, 65, 66, 68, 70, 382*b*, 382*c*, footnote 3, page 41.
 Rankine, 151.
 Rankine cycle, 411, 424, 429, 447, 544.
 Rankine's theorem, 106, 157, 158, 167.
 Rateau turbine, 524, 531, 538, 541.
 Rate of combustion, 560, 569.
 of evaporation, 569.
 of flame propagation, 309, 310, 319, 320, 325.
 of gasification, 284.
 of heat transmission, 582, 584.
 Rating automobile engines, 335.
 Ratio of expansion, 433, 436, 445, 447, 459, 549*i*.
 compound engines, 474, 476.
 real and apparent, 450.
 specific heats, 69, 70.
 Reaction in producer, 285*a*.
 Reaction turbine, 524, 533-535, 539.
 Real ratio of expansion, 450.
 Real specific heat, 61, 78.
 Réaumur thermometer, 8.
 Receiver compound engine, 464*a*-478.
 Receiver pressure, air compressor, 211.
 Recuperator, 281.
 Reevaporation, 431*a*, 444, 448, 460.
 Reeves' method, 457*a*.
 Refrigerating machine, 612, 616, 618-620, 629, 633, 636, 637, 647, 658-660, 663, 664.
 Refrigeration, 611-664.
 applications of, 649-657.
 compressed air, 227, 247.
 vapors used, 400-405.
 Regenerative expansion, 544, 610, 612.
 Regenerator, 246, 257-259, 271, 281, 295*b*, 541, 610.
 Regnault, 43, 46, 49.
 Regnault's law, 63.
 Regulation, air compressor, 238.
 gas engine, 336-338, 348, 349.
 steam engine, 462, 505*a*.
 Reheating, 481, 549*m*.
 Reitlinger cycle, 253, 259.
 Relative efficiency, 544, 551.
 Relative humidity, 382*c*.
 Representation of heat absorbed, 106, 123, 167.
 Research problems, gas power, p. 223.
 Reversibility, 139-141, 144-149.
 cycle, 138-141, 147, 148, 152, 175, 176.
 path, 125, 126, 162, 168, 175, 176.
 Rotary steam engine, 177, 192.
 Rotative speed, 445.
- Sargent cycle, 295*a*.
 Saturated air, 382*c*.
 Saturated steam, 356, 358-382.
 Saturated vapor, 356.
 Saturation curve, 365.
 Scales, thermometric, 8.
 Scavenging, 312, 327, 339.
 Second law of thermodynamics, 138-142, 144-156.
 Self-starter, 351.
 Simple engine, tests, 546, 547.
 Single-acting gas engine, 345.
 Siphon condenser, 584.
 Size of engine, 549*o*.
 Sleeve valve, 350.
 Small calorie, 23.
 Soft coal, 560, 578.
 Solution, 15, 591, 604.
 Sommeiller compressor, 240.
 Specific heat, 20, 21, 24-27, 57, 58.
 air, 71, 72.
 apparent, 61.
 difference, 65, 67, 77, 165.
 entropy diagram, 164.
 gases, 57-72.
 mean, 61, 164.
 mixtures, 382*c*.
 negative, 115, 371.
 polytropics, 112, 115, 164.
 ratio, 68, 70.
 real, 61, 78.
 saturated vapor, 401.
 superheated steam, 383-385, 387, 388.
 variable, 329*a*, 329*b*.
 volumetric, 60, 67.
 water, 24, 26, 359.

- Specific volume of steam, page 296; 360, 363, 368.
- Speed of engines, 549*a*.
of ignition, 105*a*.
piston, 445.
regulation, 505*a*.
rotative, 445.
- Starting gas engines, 351.
- Steam-air mixtures, 382*a*, 382*c*, 382*f*, 382*g*.
- Steam, formation, 354-359, 366, 381.
pressure-temperature relation, 355, 358, 362, 368.
saturated, 356, 358-382.
superheated, 355, 358, 365, 366, 380, 382*c*, 383-397.
- Steam adiabatic, 372, 373, 431, 432, 513, 515, 517-520.
- Steam boiler, 143, 566, 568-573.
- Steam consumption from indicator diagram, 437, 487, 500, 501.
- Steam cycles, 408-412, 414-418, 422-458, 483, 514, 544.
- Steam engine, 143, 419, 422-511, 550.
cycle, 408-412, 414-418, 422-458, 483, 514, 543-558.
description, 422.
entropy diagram, 453-458, 475.
governing, 462.
- Steam in gas producer, 285*a*.
- Steam-ether engine, 483.
- Steam gas, 357, 390, 391.
- Steam jacket, 413, 438-441, 466, 482, 505.
- Steam loop, 583.
- Steam power plant, 407, 508, 560-590.
- Steam refrigeration, 631, 632, 638, 643.
- Steam table, 360, 367, 376, 405, 420, 421.
- Steam turbine, 512-542, 552, 555.
- Steam, wet, 364, 367.
- Still, 591.
- Stirling hot-air engine, 260-268.
- Stoker, 578.
- Storage, compressed air, 185, 245.
- Straight-line compressor, 239.
- Stumpf engine, 507*a*.
- Stumpf turbine, 536.
- Sublimation, 17, 382*a*.
- Suction producer, 281, 282.
- Suction stroke, gas engine, 328.
- Sulphur dioxide, 404, 483, 606, 608, 611, 631, 632, Table, p. 488.
- Superheat, locomotives, 443, 509, 553.
refrigeration, 629, 633, 636, 647.
turbines, 517, 552.
use of, 438, 442-444, 482, 579.
- Superheated adiabatic, 416.
- Superheated steam, 355, 358, 365, 366, 380, 382*c*, 383-397, 544, 549*c*, 549*d*, 549*g*.
cycles, 414-418.
table, 421.
- Superheated vapor, 356.
- Superheaters, 579.
- Superheating calorimeter, 491.
- Surface condenser, 496, 502, 569, 584.
- Surface-condensing calorimeter, 490.
- Symbols, p. xiii.
- Synopses, pp. 10, 17, 29-30, 41, 70-71, 82, 89, 103-104, 141-143, 159-160, 224-226, 289-292, 355-358, 394-395, 412-413, 435-436, 451, 484-485.
- Table, air and moisture mixtures, 382*b*.
combustion data, 561.
properties of gases, 52, 63.
symbols, p. xiii.
- Table, steam, 360, 367, 376, 405, 420, 421.
- Tandem-compound, 464*a*, 467, 475, 476.
- Tank calorimeter, 489.
- Temperature, 6, 19-21.
absolute, 152-156, 167.
gas engine cylinder, 312, 314-318.
inversion, 373, 395, 401.
measurement, 6-9.
- Temperature-volume equation, footnote, p. 296.
- Testing hot air engines, 274.
- Tests, heat values, 561*a*.
- Tests, locomotive, 497, 511, 553.
refrigerating machine, 660-663
speed regulation, 505*a*.
steam boiler, 572.
steam engine, 484-505, 543-551, 554-558.
steam turbine, 543, 552, 554, 555.
- Thermal capacity, 57, 58.
- Thermal efficiency, 342, 496.
- Thermal line, 83.
- Thermochemistry, 4, 40, 53, 56, 59, 561*a*.
- Thermodynamic function, 170.
- Thermodynamic surface, 84.
- Thermo-electric pyrometer, 9.
- Thermometer, 7, 8.
air, 41, 42, 48, 49, 152.
- Thermometric scales, 8.
- Thermometry, 6-9.
- Theta-phi diagram, 170.
- Thomas' experiments, 385.
- Three-stage compressor, 211.
- Throttling, 388, 426.
- Throttling calorimeter, 491.
- Throttling engine, 427, 507.
- Throttling, gas engine, 326, 348.
- Thrust in turbines, 528.
- Time of ignition, 321.
- Tonnage rating, 658, 659.
- Total heat-entropy diagram, 399.
- Total heat-pressure diagram, 399.
- Total heat, saturated steam, 359, 360, 388.
superheated steam, 386.
- Tower, cooling, 585, 664.
- Trajectory of steam, 530.
- Transmission, air, 243-245.
gas, 276.
rate_of, 582, 584.

- Transmissive efficiency, 212, 216, 243, 244.
 Triple-expansion engine, 461, 474, 480, 543*a*, 549*a*.
 Tubes in boilers, 569.
 Turbine, gas, 540.
 exhaust steam, 540, 552.
 steam, 512-542, 552, 555, 584.
 Turbo-compressor, 239, 540.
 Turbo-locomotive, 540.
 Turbo-pump, 540.
 Two-cycle gas engine, 289-292, 329, 339.
 Two specific heats of gases, 57, 58, 62, 64-72, 107, 127*a*, 165.
 Types, air compressor, 238-242.
 gas engine, 336-341, 350-351.
 locomotive, 509, 510.
 multiple-expansion engine, 461.
 steam engine, 507.
 vapor compressor, 664.
 Uniflow engine, 507*a*.
 Universal gas constant, 52, 69.
 Vacuum, footnote, page 358.
 Vacuum distillation, 591-601.
 Vacuum pump, 236, 237, 584, 591.
 Valves, air compressor, 195, 242.
 gas engine, 310, 326, 350.
 steam engine, 350, 452, 507.
 Vapor, paths, 392-399.
 specific heat, 401.
 Vapor adiabatic, 391-397.
 Vapor compressor, 624-638, 642, 658, 660, 662, 664.
 Vapor refrigeration, 624-643, 647, 662.
 Vaporization, internal work, 359, 360.
 latent heat, 359, 360.
 Vaporizer, 279, 282, 310, 336, 612, 626.
 Vapors, 16, 17, 354-421.
 for heat engines, 402, 405*a*.
 mixtures, 382*b*.
 for refrigeration, 400-405, 630-632.
 saturated, 356.
 superheated, 356.
 Variable specific heat, 329*a*, 329*b*, 564.
 Variables, steam engine economy, 545-549*o*.
 Velocity diagram, 527, 529, 534.
 Velocity of molecules, 127*b*.
 of projectiles, 123*a*.
 in throat of nozzle, 522.
 Velocity turbine, 524, 530-533, 536-538.
 Velocity, wave, 105*a*, 316.
 Velocity work, 127, 176, 512, 518, 525.
 Vibration work, 3, 12, 13, 54-56.
 Volume curves, 377.
 Volume temperature equation, page 296.
 Volumetric efficiency, 222-229, 233.
 Volumetric specific heat, 66, 67.
 Volume, vapor, 360, 363, 368, 369, 401.
 Walls, gas engine cylinder, 312, 317, 325, 347.
 steam cylinder, 429, 431*a*, 432, 504, 505.
 vapor compressor, 637.
 Warming machine, Kelvin, 623.
 Water, air compressor, 195-200, 206, 207.
 in refrigerating plant, 617, 635.
 specific heat, 24, 26, 359.
 Water gas, 278, 281, 329.
 Water jacket, air compressor, 201, 204.
 gas engine, 312, 317, 325, 352, 353.
 Water supply, evaporator, 600.
 Water-tube boiler, 568, 569.
 Watt's diagram, 86-90.
 Watt's law, 359.
 Waves, explosion, 319, 325.
 Wave velocity, 105*a*, 316.
 Westinghouse-Parsons turbine, 539.
 Wet-bulb thermometer, 382*c*.
 Wet compression, 629, 647.
 Wet steam, 364, 367.
 Willans' line, 555.
 Wiredrawing, 426, 442, 448, 451, 474, 518, 549*j*.
 Woolf engine, 463.
 Work, Clausius cycle, 410.
 compression, 210.
 external, 14, 15, 86-90, 95, 98, 121-123, 160, 359, 374, 375.
 negative, 87, 89, 99.
 superheated adiabatic, 416.
 vapor adiabatic, 396.
 velocity, 127, 176, 512, 515, 518.
 vibration, 3, 12, 13, 54-56.
 Wormell's theorem, 36.
n, 57, 58, 62, 64-72, 101, 102, 105, 107, 110, 127*a*, 165.
 Yaryan evaporator, 595-600.
 Zero, absolute, 44, 45, 156.
 of entropy, 171.
 Zero line, 373. ■

D. VAN NOSTRAND COMPANY

25 PARK PLACE

New York

SHORT-TITLE CATALOG

OF

Publications and Importations

OF

SCIENTIFIC AND ENGINEERING
BOOKS

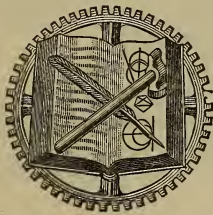

This list includes the technical publications of the following English publishers:

SCOTT, GREENWOOD & CO. CROSBY LOCKWOOD & SON
CONSTABLE & COMPANY, Ltd. TECHNICAL PUBLISHING CO.
ELECTRICIAN PRINTING & PUBLISHING CO.

for whom D. Van Nostrand Company are American agents.

FEBRUARY, 1913

SHORT-TITLE CATALOG

OF THE

Publications and Importations

OF

D. VAN NOSTRAND COMPANY

25 PARK PLACE, N. Y.

Prices marked with an asterisk () are NET.*

All bindings are in cloth unless otherwise noted.

A B C Code. (See Clausen-Thue.)

A1 Code. (See Clausen-Thue.)

Abbott, A. V. The Electrical Transmission of Energy.....	8vo,	*\$5 00
— A Treatise on Fuel. (Science Series No. 9.).....	16mo,	0 50
— Testing Machines. (Science Series No. 74.).....	16mo,	0 50
Adam, P. Practical Bookbinding. Trans. by T. E. Maw.....	12mo,	*2 50
Adams, H. Theory and Practice in Designing.....	8vo,	*2 50
Adams, H. C. Sewage of Sea Coast Towns.....	8vo,	*2 00
Adams, J. W. Sewers and Drains for Populous Districts.....	8vo,	2 50
Addyman, F. T. Practical X-Ray Work.....	8vo,	*4 00
Adler, A. A. Theory of Engineering Drawing.....	8vo,	*2 00
— Principles of Parallel Projecting-line Drawing.....	8vo,	*1 00
Aikman, C. M. Manures and the Principles of Manuring.....	8vo,	2 50
Aitken, W. Manual of the Telephone.....	8vo,	*8 00
d'Albe, E. E. F., Contemporary Chemistry.....	12mo,	*1 25
Alexander, J. H. Elementary Electrical Engineering.....	12mo,	2 00
— Universal Dictionary of Weights and Measures.....	8vo,	3 50
"Alfred." Wireless Telegraph Designs.....		
Allan, W. Strength of Beams Under Transverse Loads. (Science Series No. 19.).....	16mo,	0 50
— Theory of Arches. (Science Series No. 11.).....	16mo,	
Allen, H. Modern Power Gas Producer Practice and Applications.....	12mo,	*2 50
— Gas and Oil Engines.....	8vo,	*4 50
Anderson, F. A. Boiler Feed Water.....	8vo,	*2 50
Anderson, Capt. G. L. Handbook for the Use of Electricians.....	8vo,	3 00
Anderson, J. W. Prospector's Handbook.....	12mo,	1 50
Andés, L. Vegetable Fats and Oils.....	8vo,	*4 00
— Animal Fats and Oils. Trans. by C. Salter.....	8vo,	*4 00
— Drying Oils, Boiled Oil, and Solid and Liquid Driers.....	8vo,	*5 00
— Iron Corrosion, Anti-fouling and Anti-corrosive Paints. Trans. by C. Salter.....	8vo,	*4 00

Andés, L. Oil Colors, and Printers' Ink. Trans. by A. Morris and H. Robson.....	8vo,	*2 50
— Treatment of Paper for Special Purposes. Trans. by C. Salter.	12mo,	*2 50
Andrews, E. S. Reinforced Concrete Construction.....	12mo,	*1 25
Annual Reports on the Progress of Chemistry.		
Vol. I. (1904).....	8vo,	*2 00
Vol. II. (1905).....	8vo,	*2 00
Vol. III. (1906).....	8vo,	*2 00
Vol. IV. (1907).....	8vo,	*2 00
Vol. V. (1908).....	8vo,	*2 00
Vol. VI. (1909).....	8vo,	*2 00
Vol. VII. (1910).....	8vo,	*2 00
Vol. VIII. (1911).....	8vo,	*2 00
Argand, M. Imaginary Quantities. Translated from the French by A. S. Hardy. (Science Series No. 52.).....	16mo,	0 50
Armstrong, R., and Idell, F. E. Chimneys for Furnaces and Steam Boilers. (Science Series No. 1.).....	16mo,	0 50
Arnold, E. Armature Windings of Direct-Current Dynamos. Trans. by F. B. DeGress.....	8vo,	*2 00
Ashe, S. W., and Keiley, J. D. Electric Railways. Theoretically and Practically Treated. Vol. I. Rolling Stock.....	12mo,	*2 50
Ashe, S. W. Electric Railways. Vol. II. Engineering Preliminaries and Direct Current Sub-Stations.....	12mo,	*2 50
— Electricity: Experimentally and Practically Applied.....	12mo,	*2 00
Atkins, W. Common Battery Telephony Simplified.....	12mo,	
Atkinson, A. A. Electrical and Magnetic Calculations.....	8vo,	*1 50
Atkinson, J. J. Friction of Air in Mines. (Science Series No. 14.).....	16mo,	0 50
Atkinson, J. J., and Williams, Jr., E. H. Gases Met with in Coal Mines. (Science Series No. 13.).....	16mo,	0 50
Atkinson, P. The Elements of Electric Lighting.....	12mo,	1 50
— The Elements of Dynamic Electricity and Magnetism.....	12mo,	2 00
— Power Transmitted by Electricity.....	12mo,	2 00
Auchincloss, W. S. Link and Valve Motions Simplified.....	8vo,	*1 50
Ayrton, H. The Electric Arc.....	8vo,	*5 00
Bacon, F. W. Treatise on the Richards Steam-Engine Indicator ..	12mo,	1 00
Bailes, G. M. Modern Mining Practice. Five Volumes	8vo, each,	3 50
Bailey, R. D. The Brewers' Analyst.....	8vo,	*5 00
Baker, A. L. Quaternions.....	8vo,	*1 25
— Thick-Lens Optics.....	12mo,	*1 50
Baker, Benj. Pressure of Earthwork. (Science Series No. 56.).....	16mo)	
Baker, I. O. Levelling. (Science Series No. 91.).....	16mo,	0 50
Baker, M. N. Potable Water. (Science Series No. 61.).....	16mo,	0 50
— Sewerage and Sewage Purification. (Science Series No. 18.).....	16mo,	0 50
Baker, T. T. Telegraphic Transmission of Photographs.....	12mo,	*1 25
Bale, G. R. Modern Iron Foundry Practice. Two Volumes. 12mo.		
Vol. I. Foundry Equipment, Materials Used.....		*2 50
Vol. II. Machine Moulding and Moulding Machines.....		*1 50
Bale, M. P. Pumps and Pumping.....	12mo,	1 50
Ball, J. W. Concrete Structures in Railways. (<i>In Press.</i>).....	8vo,	

Ball, R. S. Popular Guide to the Heavens.....	8vo,	*4 50
— Natural Sources of Power. (Westminster Series.)	8vo,	*2 00
Ball, W. V. Law Affecting Engineers.....	8vo,	*3 50
Bankson, Lloyd. Slide Valve Diagrams. (Science Series No. 108.) ..	16mo,	0 50
Barba, J. Use of Steel for Constructive Purposes.....	12mo,	1 00
Barham, G. B. Development of the Incandescent Electric Lamp....	8vo,	*2 00
Barker, A. Textiles and Their Manufacture. (Westminster Series.) ..	8vo,	2 00
Barker, A. H. Graphic Methods of Engine Design.....	12mo,	*1 50
Barnard, F. A. P. Report on Machinery and Processes of the Industrial Arts and Apparatus of the Exact Sciences at the Paris Universal Exposition, 1867.....	8vo,	5 00
Barnard, J. H. The Naval Militiaman's Guide.....	16mo, leather	1 25
Barnard, Major J. G. Rotary Motion. (Science Series No. 90.)....	16mo,	0 50
Barrus, G. H. Boiler Tests.....	8vo,	*3 00
— Engine Tests.....	8vo,	*4 00
The above two purchased together.....		*6 00
Barwise, S. The Purification of Sewage.....	12mo,	3 50
Baterden, J. R. Timber. (Westminster Series.).....	8vo,	*2 00
Bates, E. L., and Charlesworth, F. Practical Mathematics.....	12mo,	
Part I. Preliminary and Elementary Course.....		*1 50
Part II. Advanced Course.....		*1 50
— Practical Mathematics.....	12mo,	*1 50
— Practical Geometry and Graphics.....	12mo,	*2 00
Beadle, C. Chapters on Papermaking. Five Volumes.....	12mo, each,	*2 00
Beaumont, R. Color in Woven Design.....	8vo,	*6 00
— Finishing of Textile Fabrics.....	8vo,	*4 00
Beaumont, W. W. The Steam-Engine Indicator.....	8vo,	2 50
Bechhold. Colloids in Biology and Medicine. Trans. by J. G. Bullowa (In Press.).....		
Beckwith, A. Pottery.....	8vo, paper,	0 60
Bedell, F., and Pierce, C. A. Direct and Alternating Current Manual.....	8vo,	*2 00
Beech, F. Dyeing of Cotton Fabrics.....	8vo,	*3 00
— Dyeing of Woolen Fabrics.....	8vo,	*3 50
Begtrup, J. The Slide Valve.....	8vo,	*2 00
Beggs, G. E. Stresses in Railway Girders and Bridges..... (In Press.)		
Bender, C. E. Continuous Bridges. (Science Series No. 26.)....	16mo,	0 50
— Proportions of Piers used in Bridges. (Science Series No. 4.)	16mo,	0 50
Bennett, H. G. The Manufacture of Leather.....	8vo,	*4 50
— Leather Trades (Outlines of Industrial Chemistry). 8vo. (In Press.)		
Bernthsen, A. A Text-book of Organic Chemistry. Trans. by G. M'Gowan.....	12mo,	*2 50
Berry, W. J. Differential Equations of the First Species. 12mo. (In Preparation.)		
Bersch, J. Manufacture of Mineral and Lake Pigments. Trans. by A. C. Wright.....	8vo,	*5 00
Bertin, L. E. Marine Boilers. Trans. by L. S. Robertson.....	8vo,	5 00
Beveridge, J. Papermaker's Pocket Book.....	12mo,	*4 00
Binns, C. F. Ceramic Technology.....	8vo,	*5 00
— Manual of Practical Potting.....	8vo,	*7 50
— The Potter's Craft.....	12mo,	*2 00
Birchmore, W. H. Interpretation of Gas Analysis.....	12mo,	*1 25

Blaine, R. G.	The Calculus and Its Applications.....	12mo,	*1 50
Blake, W. H.	Brewers' Vade Mecum.....	8vo,	*4 00
Blake, W. P.	Report upon the Precious Metals.....	8vo,	2 00
Bligh, W. G.	The Practical Design of Irrigation Works.....	8vo,	*6 00
Blücher, H.	Modern Industrial Chemistry. Trans. by J. P. Millington	8vo,	*7 50
Blyth, A. W.	Foods: Their Composition and Analysis.....	8vo,	7 50
—	Poisons: Their Effects and Detection.....	8vo,	7 50
Böckmann, F.	Celluloid.....	12mo,	*2 50
Bodmer, G. R.	Hydraulic Motors and Turbines.....	12mo,	5 00
Boileau, J. T.	Traverse Tables.....	8vo,	5 00
Bonney, G. E.	The Electro-platers' Handbook.....	12mo,	1 20
Booth, N.	Guide to the Ring-spinning Frame.....	12mo,	*1 25
Booth, W. H.	Water Softening and Treatment.....	8vo,	*2 50
—	Superheaters and Superheating and Their Control.....	8vo,	*1 50
Bottcher, A.	Cranes: Their Construction, Mechanical Equipment and Working. Trans. by A. Tolhausen.....	4to,	*10 00
Bottler, M.	Modern Bleaching Agents. Trans. by C. Salter.....	12mo,	*2 50
Bottone, S. R.	Magnetos for Automobilists.....	12mo,	*1 00
Boulton, S. B.	Preservation of Timber. (Science Series No. 82.).....	16mo,	0 50
Bourgougnon, A.	Physical Problems. (Science Series No. 113.).....	16mo,	0 50
Bourry, E.	Treatise on Ceramic Industries. Trans. by A. B. Searle.	8vo,	*5 00
Bow, R. H.	A Treatise on Bracing.....	8vo,	1 50
Bowie, A. J., Jr.	A Practical Treatise on Hydraulic Mining.....	8vo,	5 00
Bowker, W. R.	Dynamo, Motor and Switchboard Circuits.....	8vo,	*2 50
Bowles, O.	Tables of Common Rocks. (Science Series No. 125.).....	16mo,	0 50
Bowser, E. A.	Elementary Treatise on Analytic Geometry.....	12mo,	1 75
—	Elementary Treatise on the Differential and Integral Calculus.....	12mo,	2 25
—	Elementary Treatise on Analytic Mechanics.....	12mo,	3 00
—	Elementary Treatise on Hydro-mechanics.....	12mo,	2 50
—	A Treatise on Roofs and Bridges.....	12mo,	*2 25
Boycott, G. W. M.	Compressed Air Work and Diving.....	8vo,	*4 00
Bragg, E. M.	Marine Engine Design.....	12mo,	*2 00
Brainard, F. R.	The Sextant. (Science Series No. 101.).....	16mo,	
Brassey's Naval Annual for 1911.....		8vo,	*6 00
Brew, W.	Three-Phase Transmission.....	8vo,	*2 00
Brewer, R. W. A.	Motor Car Construction.....	8vo,	*2 00
Briggs, R., and Wolff, A. R.	Steam-Heating. (Science Series No. 67.).....	16mo,	0 50
Bright, C.	The Life Story of Sir Charles Tilson Bright.....	8vo,	*4 50
Brislee, T. J.	Introduction to the Study of Fuel. (Outlines of Industrial Chemistry).....	8vo,	*3 00
British Standard Sections.....		8x15	*1 00
Complete list of this series (45 parts) sent on application.			
Broadfoot, S. K.	Motors, Secondary Batteries. (Installation Manuals Series).....	12mo,	*0 75
Broughton, H. H.	Electric Cranes and Hoists.....		*9 00
Brown, G.	Healthy Foundations. (Science Series No. 80.).....	16mo,	0 50
Brown, H.	Irrigation.....	8vo,	*5 00
Brown, Wm. N.	The Art of Enamelling on Metal.....	12mo,	*1 00

Brown, Wm. N. Handbook on Japanning and Enamelling	12mo,	*1 50
— House Decorating and Painting	12mo,	*1 50
— History of Decorative Art	12mo,	*1 25
— Dipping, Burnishing, Lacquering and Bronzing Brass Ware	12mo,	*1 00
— Workshop Wrinkles	8vo,	*1 00
Browne, R. E. Water Meters. (Science Series No. 81.)	16mo,	0 50
Bruce, E. M. Pure Food Tests	12mo,	*1 25
Bruhns, Dr. New Manual of Logarithms	8vo, half morocco,	2 00
Brunner, R. Manufacture of Lubricants, Shoe Polishes and Leather Dressings. Trans. by C. Salter	8vo,	*3 00
Buel, R. H. Safety Valves. (Science Series No. 21.)	16mo,	0 50
Bulman, H. F., and Redmayne, R. S. A. Colliery Working and Management	8vo,	6 00
Burgh, N. P. Modern Marine Engineering	4to, half morocco,	10 00
Burstall, F. W. Energy Diagram for Gas. With Text	8vo,	1 50
— Diagram. Sold separately		*1 00
Burt, W. A. Key to the Solar Compass	16mo, leather,	2 50
Burton, F. G. Engineering Estimates and Cost Accounts	12mo,	*1 50
Buskett, E. W. Fire Assaying	12mo,	*1 25
Butler, H. J. Motor Bodies and Chassis	8vo,	*2 50
Byers, H. G., and Knight, H. G. Notes on Qualitative Analysis	8vo,	*1 50
Cain, W. Brief Course in the Calculus	12mo,	*1 75
— Elastic Arches. (Science Series No. 48.)	16mo,	0 50
— Maximum Stresses. (Science Series No. 38.)	16mo,	0 50
— Practical Designing Retaining of Walls. (Science Series No. 3.)	16mo,	0 50
— Theory of Steel-concrete Arches and of Vaulted Structures. (Science Series No. 42.)	16mo,	0 50
— Theory of Voussoir Arches. (Science Series No. 12.)	16mo,	0 50
— Symbolic Algebra. (Science Series No. 73.)	16mo,	0 50
Campin, F. The Construction of Iron Roofs	8vo,	2 00
Carpenter, F. D. Geographical Surveying. (Science Series No. 37.)	16mo,	
Carpenter, R. C., and Diederichs, H. Internal Combustion Engines	8vo,	*5 00
Carter, E. T. Motive Power and Gearing for Electrical Machinery	8vo,	*5 00
Carter, H. A. Ramie (Rhea), China Grass	12mo,	*2 00
Carter, H. R. Modern Flax, Hemp, and Jute Spinning	8vo,	*3 00
Cathcart, W. L. Machine Design. Part I. Fastenings	8vo,	*3 00
Cathcart, W. L., and Chaffee, J. I. Elements of Graphic Statics	8vo,	*3 00
— Short Course in Graphics	12mo,	1 50
Caven, R. M., and Lander, G. D. Systematic Inorganic Chemistry	12mo,	*2 00
Chalkley, A. P. Diesel Engines	8vo,	*3 00
Chambers' Mathematical Tables	8vo,	1 75
Charnock, G. F. Workshop Practice. (Westminster Series.)	8vo (In Press.)	
Charpentier, P. Timber	8vo,	*6 00
Chatley, H. Principles and Designs of Aeroplanes. (Science Series.)		
No. 126.)	16mo,	0 50
— How to Use Water Power	12mo,	*1 00
— Gyrostatic Balancing	8vo,	*1 00
Child, C. D. Electric Arc	8vo, *(In Press.)	

D. VAN NOSTRAND COMPANY'S SHORT TITLE CATALOG 7

Child, C. T. The How and Why of Electricity.....	12mo,	1 00
Christie, W. W. Boiler-waters, Scale, Corrosion, Foaming.....	8vo,	*3 00
— Chimney Design and Theory.....	8vo,	*3 00
— Furnace Draft. (Science Series No. 123.).....	16mo,	0 50
— Water: Its Purification and Use in the Industries.....	8vo,	*2 00
Church's Laboratory Guide. Rewritten by Edward Kinch.....	8vo,	*2 50
Clapperton, G. Practical Papermaking.....	8vo,	2 50
Clark, A. G. Motor Car Engineering ₃ .		
Vol. I. Construction.....		*3 00
Vol. II. Design.....	(In Press.)	
Clark, C. H. Marine Gas Engines.....	12mo,	*1 50
Clark, D. K. Rules, Tables and Data for Mechanical Engineers....	8vo,	5 00
— Fuel: Its Combustion and Economy.....	12mo,	1 50
— The Mechanical Engineer's Pocketbook.....	16mo,	2 00
— Tramways: Their Construction and Working.....	8vo,	5 00
Clark, J. M. New System of Laying Out Railway Turnouts.....	12mo,	1 00
Clausen-Thue, W. A B C Telegraphic Code. Fourth Edition....	12mo,	*5 00
Fifth Edition.....	8vo,	*7 00
— The A 1 Telegraphic Code.....	8vo,	*7 50
Cleemann, T. M. The Railroad Engineer's Practice.....	12mo,	*1 50
Clerk, D., and Idell, F. E. Theory of the Gas Engine. (Science Series No. 62.).....	16mo,	0 50
Clevenger, S. R. Treatise on the Method of Government Surveying. 16mo, morocco.....		2 50
Clouth, F. Rubber, Gutta-Percha, and Balata.....	8vo,	*5 00
Cochran, J. Treatise on Cement Specifications.....	8vo,	*1 00
Coffin, J. H. C. Navigation and Nautical Astronomy.....	12mo,	*3 50
Colburn, Z., and Thurston, R. H. Steam Boiler Explosions. (Science Series No. 2.).....	16mo,	0 50
Cole, R. S. Treatise on Photographic Optics.....	12mo,	1 50
Coles-Finch, W. Water, Its Origin and Use.....	8vo,	*5 00
Collins, J. E. Useful Alloys and Memoranda for Goldsmiths, Jewelers. 16mo.....		0 50
Constantine, E. Marine Engineers, Their Qualifications and Duties. 8vo,		*2 00
Coombs, H. A. Gear Teeth. (Science Series No. 120.).....	16mo,	0 50
Cooper, W. R. Primary Batteries.....	8vo,	*4 00
— "The Electrician" Primers.....	8vo,	*5 00
Part I.....		*1 50
Part II.....		*2 50
Part III.....		*2 00
Copperthwaite, W. C. Tunnel Shields.....	4to,	*9 00
Corey, H. T. Water Supply Engineering.....	8vo (In Press.)	
Corfield, W. H. Dwelling Houses. (Science Series No. 50.).....	16mo,	0 50
— Water and Water-Supply. (Science Series No. 17.).....	16mo,	0 50
Cornwall, H. B. Manual of Blow-pipe Analysis.....	8vo,	*2 50
Courtney, C. F. Masonry Dams.....	8vo,	3 50
Cowell, W. B. Pure Air, Ozone, and Water.....	12mo,	*2 00
Craig, T. Motion of a Solid in a Fuel. (Science Series No. 49.)....	16mo,	0 50
— Wave and Vortex Motion. (Science Series No. 43.).....	16mo,	0 50
Cramp, W. Continuous Current Machine Design.....	8vo,	*2 50

Crocker, F. B. Electric Lighting. Two Volumes. 8vo.		
Vol. I. The Generating Plant.....	3	00
Vol. II. Distributing Systems and Lamps.....	3	00
Crocker, F. B., and Arendt, M. Electric Motors.....	8vo,	*2 50
Crocker, F. B., and Wheeler, S. S. The Management of Electrical Machinery.....	12mo,	*1 00
Cross, C. F., Bevan, E. J., and Sindall, R. W. Wood Pulp and Its Applications. (Westminster Series.).....	8vo,	*2 00
Crosskey, L. R. Elementary Perspective.....	8vo,	1 00
Crosskey, L. R., and Thaw, J. Advanced Perspective.....	8vo,	1 50
Culley, J. L. Theory of Arches. (Science Series No. 87.).....	16mo,	0 50
Dadourian, H. M. Analytical Mechanics.....	12mo, (<i>In Press.</i>)	
Davenport, C. The Book. (Westminster Series.).....	8vo,	*2 00
Davies, D. C. Metalliferous Minerals and Mining.....	8vo,	5 00
— Earthy Minerals and Mining.....	8vo,	5 0c
Davies, E. H. Machinery for Metalliferous Mines.....	8vo,	8 00
Davies, F. H. Electric Power and Traction.....	8vo,	*2 00
— Foundations and Machinery Fixing. (Installation Manual Series.)	16mo, (<i>In Press.</i>)	
Dawson, P. Electric Traction on Railways.....	8vo,	*9 00
Day, C. The Indicator and Its Diagrams.....	12mo,	*2 00
Deerr, N. Sugar and the Sugar Cane.....	8vo,	*8 00
Deite, C. Manual of Soapmaking. Trans. by S. T. King.....	4to,	*5 00
De la Coux, H. The Industrial Uses of Water. Trans. by A. Morris.	8vo,	*4 50
Del Mar, W. A. Electric Power Conductors.....	8vo,	*2 00
Denny, G. A. Deep-level Mines of the Rand.....	4to,	*10 00
— Diamond Drilling for Gold.....		*5 00
De Roos, J. D. C. Linkages. (Science Series No. 47.).....	16mo,	0 50
Derr, W. L. Block Signal Operation.....	Oblong 12mo,	*1 50
— Maintenance-of-Way Engineering.....	(<i>In Preparation.</i>)	
Desaint, A. Three Hundred Shades and How to Mix Them.....	8vo,	*10 00
De Varona, A. Sewer Gases. (Science Series No. 55.).....	16mo,	0 50
Devey, R. G. Mill and Factory Wiring. (Installation Manuals Series.)	12mo,	*1 00
Dibdin, W. J. Public Lighting by Gas and Electricity.....	8vo,	*8 00
— Purification of Sewage and Water.....	8vo,	6 50
Dichmann, Carl. Basic Open-Hearth Steel Process.....	12mo,	*3 50
Dieterich, K. Analysis of Resins, Balsams, and Gum Resins.....	8vo,	*3 00
Dinger, Lieut. H. C. Care and Operation of Naval Machinery.....	12mo,	*2 00
Dixon, D. B. Machinist's and Steam Engineer's Practical Calculator.	16mo, morocco,	1 25
Doble, W. A. Power Plant Construction on the Pacific Coast (<i>In Press.</i>)		
Dodd, G. Dictionary of Manufactures, Mining, Machinery, and the Industrial Arts.....	12mo,	1 50
Dorr, B. F. The Surveyor's Guide and Pocket Table-book.	16mo, morocco,	2 00
Down, P. B. Handy Copper Wire Table.....	16mo,	*1 00
Draper, C. H. Elementary Text-book of Light, Heat and Sound.....	12mo,	1 00
— Heat and the Principles of Thermo-dynamics.....	12mo,	1 50

D. VAN NOSTRAND COMPANY'S SHORT TITLE CATALOG 9

Duckwall, E. W. Canning and Preserving of Food Products.....	8vo,	*5 00
Dumesny, P., and Noyer, J. Wood Products, Distillates, and Extracts.	8vo,	*4 50
Duncan, W. G., and Penman, D. The Electrical Equipment of Collieries.	8vo,	*4 00
Dunstan, A. E., and Thole, F. B. T. Textbook of Practical Chemistry.	12mo,	*1 40
Duthie, A. L. Decorative Glass Processes. (Westminster Series.)	8vo,	*2 00
Dwight, H. B. Transmission Line Formulas.....	8vo, (<i>In Press.</i>)	
Dyson, S. S. Practical Testing of Raw Materials.....	8vo,	*5 00
Dyson, S. S., and Clarkson, S. S. Chemical Works	8vo,	*7 50
Eccles, R. G., and Duckwall, E. W. Food Preservatives.....	8vo, paper	0 50
Eddy, H. T. Researches in Graphical Statics	8vo,	1 50
— Maximum Stresses under Concentrated Loads.....	8vo,	1 50
Edgcombe, K. Industrial Electrical Measuring Instruments.....	8vo,	*2 50
Eissler, M. The Metallurgy of Gold.....	8vo,	7 50
— The Hydrometallurgy of Copper.....	8vo,	*4 50
— The Metallurgy of Silver.....	8vo,	4 00
— The Metallurgy of Argentiferous Lead.....	8vo,	5 00
— Cyanide Process for the Extraction of Gold.....	8vo,	3 00
— A Handbook on Modern Explosives.....	8vo,	5 00
Ekin, T. C. Water Pipe and Sewage Discharge Diagrams.....	folio,	*3 00
Eliot, C. W., and Storer, F. H. Compendious Manual of Qualitative Chemical Analysis.....	12mo,	*1 25
Elliot, Major G. H. European Light-house Systems.....	8vo,	5 00
Ennis, Wm. D. Linseed Oil and Other Seed Oils.....	8vo,	*4 00
— Applied Thermodynamics.....	8vo	*4 50
— Flying Machines To-day.....	12mo,	*1 50
— Vapors for Heat Engines.....	12mo,	*1 00
Erfurt, J. Dyeing of Paper Pulp. Trans. by J. Hubner.....	8vo,	*7 50
Ermen, W. F. A. Materials Used in Sizing.....	8vo,	*2 00
Erskine-Murray, J. A Handbook of Wireless Telegraphy.....	8vo,	*3 50
Evans, C. A. Macadamized Roads.....	(<i>In Press.</i>)	
Ewing, A. J. Magnetic Induction in Iron.....	8vo,	*4 00
Fairie, J. Notes on Lead Ores.....	12mo,	*1 00
— Notes on Pottery Clays.....	12mo,	*1 50
Fairley, W., and Andre, Geo. J. Ventilation of Coal Mines. (<i>Science Series No. 58.</i>).....	16mo,	0 50
Fairweather, W. C. Foreign and Colonial Patent Laws.....	8vo,	*3 00
Fanning, J. T. Hydraulic and Water-supply Engineering.....	8vo,	*5 00
Fauth, P. The Moon in Modern Astronomy. Trans. by J. McCabe.	8vo,	*2 00
Fay, I. W. The Coal-tar Colors.....	8vo,	*4 00
Fernbach, R. L. Glue and Gelatine.....	8vo,	*3 00
— Chemical Aspects of Silk Manufacture.....	12mo,	*1 00
Fischer, E. The Preparation of Organic Compounds. Trans. by R. V. Stanford.....	12mo,	*1 25
Fish, J. C. L. Lettering of Working Drawings	Oblong 8vo,	1 00
Fisher, H. K. C., and Darby, W. C. Submarine Cable Testing.....	8vo,	*3 50

10 D. VAN NOSTRAND COMPANY'S SHORT TITLE CATALOG

Fiske, Lieut. B. A. Electricity in Theory and Practice.....	8vo,	2 50
Fleischmann, W. The Book of the Dairy. Trans. by C. M. Aikman.	8vo,	4 00
Fleming, J. A. The Alternate-current Transformer. Two Volumes. 8vo.		
Vol. I. The Induction of Electric Currents.....		*5 00
Vol. II. The Utilization of Induced Currents.....		*5 00
— Propagation of Electric Currents.....	8vo,	*3 00
— Centenary of the Electrical Current.....	8vo,	*0 50
— Electric Lamps and Electric Lighting.....	8vo,	*3 00
— Electrical Laboratory Notes and Forms.....	4to,	*5 00
— A Handbook for the Electrical Laboratory and Testing Room. Two Volumes.....	8vo, each,	*5 00
Fleury, P. Preparation and Uses of White Zinc Paints.....	8vo,	*2 50
Fluery, H. The Calculus Without Limits or Infinitesimals. Trans. by C. O. Mailloux.....	(In Press.)	
Flynn, P. J. Flow of Water. (Science Series No. 84.).....	16mo,	0 50
— Hydraulic Tables. (Science Series No. 66.).....	16mo,	0 50
Foley, N. British and American Customary and Metric Measures. folio,		*3 00
Foster, H. A. Electrical Engineers' Pocket-book. (Sixth Edition.)	12mo, leather,	5 00
— Engineering Valuation of Public Utilities and Factories.....	8vo,	*3 00
Foster, Gen. J. G. Submarine Blasting in Boston (Mass.) Harbor....	4to,	3 50
Fowle, F. F. Overhead Transmission Line Crossings.....	12mo,	*1 50
— The Solution of Alternating Current Problems.....	8vo (In Press.)	
Fox, W. G. Transition Curves. (Science Series No. 110.).....	16mo,	0 50
Fox, W., and Thomas, C. W. Practical Course in Mechanical Drawing.....	12mo,	1 25
Foye, J. C. Chemical Problems. (Science Series No. 69.).....	16mo,	0 50
— Handbook of Mineralogy. (Science Series No. 86.).....	16mo,	0 50
Francis, J. B. Lowell Hydraulic Experiments.....	4to,	15 00
Freudemacher, P. W. Electrical Mining Installations. (Installation Manuals Series.).....	12mo,	*1 00
Frith, J. Alternating Current Design.....	8vo,	*2 00
Fritsch, J. Manufacture of Chemical Manures. Trans. by D. Grant.	8vo,	*4 00
Frye, A. I. Civil Engineers' Pocket-book.....	12mo, leather,	*5 00
Fuller, G. W. Investigations into the Purification of the Ohio River.	4to.	*10 00
Furnell, J. Paints, Colors, Oils, and Varnishes.....	8vo,	*1 00
Gairdner, J. W. I. Earthwork.....	8vo, (In Press.)	
Gant, L. W. Elements of Electric Traction.....	8vo,	*2 50
Garcia, A. J. R. V. Spanish-English Railway Terms.....	8vo,	*4 50
Garforth, W. E. Rules for Recovering Coal Mines after Explosions and Fires.....	12mo, leather,	1 50
Gaudard, J. Foundations. (Science Series No. 34.).....	16mo,	0 50
Gear, H. B., and Williams, P. F. Electric Central Station Distribution Systems.....	8vo,	*3 00
Geerligs, H. C. P. Cane Sugar and Its Manufacture.....	8vo,	*5 00
— World's Cane Sugar Industry.....	8vo,	*5 00
Geikie, J. Structural and Field Geology.....	8vo,	*4 00

Gerber, N. Analysis of Milk, Condensed Milk, and Infants' Milk-Food. 8vo,	1	25
Gerhard, W. P. Sanitation, Watersupply and Sewage Disposal of Country Houses.	12mo,	*2 00
— Gas Lighting. (Science Series No. 111.).....	16mo,	0 50
— Household Wastes. (Science Series No. 97.).....	16mo,	0 50
— House Drainage. (Science Series No. 63.).....	16mo,	0 50
— Sanitary Drainage of Buildings. (Science Series No. 93.)....	16mo,	0 50
Gerhardi, C. W. H. Electricity Meters.....	8vo,	*4 00
Geschwind, L. Manufacture of Alum and Sulphates. Trans. by C. Salter.....	8vo,	*5 00
Gibbs, W. E. Lighting by Acetylene.....	12mo,	*1 50
— Physics of Solids and Fluids. (Carnegie Technical School's Text-books.).....		*1 50
Gibson, A. H. Hydraulics and Its Application.....	8vo,	*5 00
— Water Hammer in Hydraulic Pipe Lines.....	12mo,	*2 00
Gilbreth, F. B. Motion Study.....	12mo,	*2 00
— Primer of Scientific Management.....	12mo,	*1 00
Gillmore, Gen. Q. A. Limes, Hydraulic Cements and Mortars.....	8vo,	4 00
— Roads, Streets, and Pavements.....	12mo,	2 00
Golding, H. A. The Theta-Phi Diagram.....	12mo,	*1 25
Goldschmidt, R. Alternating Current Commutator Motor.....	8vo,	*3 00
Goodchild, W. Precious Stones. (Westminster Series.).....	8vo,	*2 00
Goodeve, T. M. Textbook on the Steam-engine.....	12mo,	2 00
Gore, G. Electrolytic Separation of Metals.....	8vo,	*3 50
Gould, E. S. Arithmetic of the Steam-engine.....	12mo,	1 00
— Calculus. (Science Series No. 112.).....	16mo,	0 50
— High Masonry Dams. (Science Series No. 22.).....	16mo,	0 50
— Practical Hydrostatics and Hydrostatic Formulas. (Science Series No. 117.).....	16mo,	0 50
Grant, J. Brewing and Distilling. (Westminster Series.) 8vo (<i>In Press.</i>)		
Gratacap, L. P. A Popular Guide to Minerals.....	8vo,	*3 00
Gray, J. Electrical Influence Machines.....	12mo,	2 00
— Marine Boiler Design.....	12mo,	*1 25
Greenhill, G. Dynamics of Mechanical Flight.....	8vo,	*2 50
Greenwood, E. Classified Guide to Technical and Commercial Books. 8vo,		*3 00
Gregorius, R. Mineral Waxes. Trans. by C. Salter.....	12mo,	*3 00
Griffiths, A. B. A Treatise on Manures.....	12mo,	3 00
— Dental Metallurgy.....	8vo,	*3 50
Gross, E. Hops.....	8vo,	*4 50
Grossman, J. Ammonia and Its Compounds.....	12mo,	*1 25
Groth, L. A. Welding and Cutting Metals by Gases or Electricity....	8vo,	*3 00
Grover, F. Modern Gas and Oil Engines.....	8vo,	*2 00
Gruner, A. Power-loom Weaving.....	8vo,	*3 00
Guldner, Hugo. Internal Combustion Engines. Trans. by H. Diederichs.	4to,	*10 00
Gunther, C. O. Integration.....	12mo,	*1 25
Gurden, R. L. Traverse Tables.....	folio, half morocco,	*7 50
Guy, A. E. Experiments on the Flexure of Beams.....	8vo,	*1 25
Haeder, H. Handbook on the Steam-engine. Trans. by H. H. P. Powles.....	12mo,	3 00

Hainbach, R. Pottery Decoration. Trans. by C. Slater.....	12mo,	*3 00
Haenig, A. Emery and Emery Industry.....	8vo,	*2 50
Hale, W. J. Calculations of General Chemistry.....	12mo,	*1 00
Hall, C. H. Chemistry of Paints and Paint Vehicles.....	12mo,	*2 00
Hall, R. H. Governors and Governing Mechanism.....	12mo,	*2 00
Hall, W. S. Elements of the Differential and Integral Calculus.....	8vo,	*2 25
— Descriptive Geometry.....	8vo volume and a 4to atlas,	*3 50
Haller, G. F., and Cunningham, E. T. The Tesla Coil.....	12mo,	*1 25
Halsey, F. A. Slide Valve Gears.....	12mo,	1 50
— The Use of the Slide Rule. (Science Series No. 114.).....	16mo,	0 50
— Worm and Spiral Gearing. (Science Series No. 116.).....	16mo,	0 50
Hamilton, W. G. Useful Information for Railway Men.....	16mo,	1 00
Hammer, W. J. Radium and Other Radio-active Substances.....	8vo,	*1 00
Hancock, H. Textbook of Mechanics and Hydrostatics.....	8vo,	1 50
Hardy, E. Elementary Principles of Graphic Statics.....	12mo,	*1 50
Harrison, W. B. The Mechanics' Tool-book.....	12mo,	1 50
Hart, J. W. External Plumbing Work.....	8vo,	*3 00
— Hints to Plumbers on Joint Wiping.....	8vo,	*3 00
— Principles of Hot Water Supply.....	8vo,	*3 00
— Sanitary Plumbing and Drainage.....	8vo,	*3 00
Haskins, C. H. The Galvanometer and Its Uses.....	16mo,	1 50
Hatt, J. A. H. The Colorist.....	square 12mo,	*1 50
Hausbrand, E. Drying by Means of Air and Steam. Trans. by A. C. Wright.....	12mo,	*2 00
— Evaporating, Condensing and Cooling Apparatus. Trans. by A. C. Wright.....	8vo,	*5 00
Hausner, A. Manufacture of Preserved Foods and Sweetmeats. Trans. by A. Morris and H. Robson.....	8vo,	*3 00
Hawke, W. H. Premier Cipher Telegraphic Code.....	4to,	*5 00
— 100,000 Words Supplement to the Premier Code.....	4to,	*5 00
Hawkesworth, J. Graphical Handbook for Reinforced Concrete Design.....	4to,	*2 50
Hay, A. Alternating Currents.....	8vo,	*2 50
— Electrical Distributing Networks and Distributing Lines.....	8vo,	*3 50
— Continuous Current Engineering.....	8vo,	*2 50
Heap, Major D. P. Electrical Appliances.....	8vo,	2 00
Heather, H. J. S. Electrical Engineering.....	8vo,	*3 50
Heaviside, O. Electromagnetic Theory. Vols. I and II.....	8vo, each,	*5 00
Vol. III.....	8vo,	*7 50
Heck, R. C. H. The Steam Engine and Turbine.....	8vo,	*5 00
— Steam-Engine and Other Steam Motors. Two Volumes.		
Vol. I. Thermodynamics and the Mechanics.....	8vo,	*3 50
Vol. II. Form, Construction, and Working.....	8vo,	*5 00
— Notes on Elementary Kinematics.....	8vo, boards,	*1 00
— Graphics of Machine Forces.....	8vo, boards,	*1 00
Hedges, K. Modern Lightning Conductors.....	8vo,	3 00
Heermann, P. Dyers' Materials. Trans. by A. C. Wright.....	12mo,	*2 50
Hellot, Macquer and D'Apligny. Art of Dyeing Wool, Silk and Cotton.....	8vo,	*2 00
Henrici, O. Skeleton Structures.....	8vo,	1 50
Hering, D. W. Essentials of Physics for College Students.....	8vo,	*1 60
Hering-Shaw, A. Domestic Sanitation and Plumbing. Two Vols.....	8vo,	*5 00

Hering-Shaw, A. Elementary Science	8vo,	*2 00
Herrmann, G. The Graphical Statics of Mechanism. Trans. by A. P. Smith.....	12mo,	2 00
Herzfeld, J. Testing of Yarns and Textile Fabrics.....	8vo,	*3 50
Hildebrandt, A. Airships, Past and Present.....	8vo,	*3 50
Hildenbrand, B. W. Cable-Making. (Science Series No. 32.).....	16mo,	0 50
Hilditch, T. P. A Concise History of Chemistry.....	12mo,	*1 25
Hill, J. W. The Purification of Public Water Supplies. New Edition. (In Press.)		
—— Interpretation of Water Analysis.....	(In Press.)	
Hiroi, I. Plate Girder Construction. (Science Series No. 95.).....	16mo,	0 50
—— Statically-Indeterminate Stresses.....	12mo,	*2 00
Hirshfeld, C. F. Engineering Thermodynamics. (Science Series No. 45.)	16mo,	0 50
Hobart, H. M. Heavy Electrical Engineering.....	8vo,	*4 50
—— Design of Static Transformers.....	12mo,	*2 00
—— Electricity.....	8vo,	*2 00
—— Electric Trains.....	8vo,	*2 50
Hobart, H. M. Electric Propulsion of Ships.....	8vo,	*2 00
Hobart, J. F. Hard Soldering, Soft Soldering and Brazing.....	12mo,	*1 00
Hobbs, W. R. P. The Arithmetic of Electrical Measurements.....	12mo,	0 50
Hoff, J. N. Paint and Varnish Facts and Formulas.....	12mo,	*1 50
Hoff, Com. W. B. The Avoidance of Collisions at Sea.....	16mo, morocco,	0 75
Hole, W. The Distribution of Gas.....	8vo,	*7 50
Holley, A. L. Railway Practice.....	folio,	12 00
Holmes, A. B. The Electric Light Popularly Explained.....	12mo, paper,	0 50
Hopkins, N. M. Experimental Electrochemistry.....	8vo,	*3 00
—— Model Engines and Small Boats.....	12mo,	1 25
Hopkinson, J. Shoolbred, J. N., and Day, R. E. Dynamic Electricity. (Science Series No. 71.).....	16mo,	0 50
Horner, J. Engineers' Turning.....	8vo,	*3 50
—— Metal Turning.....	12mo,	1 50
—— Toothed Gearing.....	12mo,	2 25
Houghton, C. E. The Elements of Mechanics of Materials.....	12mo,	*2 00
Houllevigue, L. The Evolution of the Sciences.....	8vo,	*2 00
Houstoun, R. A. Studies in Light Production.....	12mo,	*2 00
Howe, G. Mathematics for the Practical Man.....	12mo,	*1 25
Howorth, J. Repairing and Riveting Glass, China and Earthenware. 8vo, paper,		*0 50
Hubbard, E. The Utilization of Wood-waste.....	8vo,	*2 50
Hübner, J. Bleaching and Dyeing of Vegetable and Fibrous Materials (Outlines of Industrial Chemistry).....	8vo,	*5 00
Hudson, O. F. Iron and Steel. (Outlines of Industrial Chemistry.) 8vo, (In Press.)		
Humper, W. Calculation of Strains in Girders.....	12mo,	2 50
Humphreys, A. C. The Business Features of Engineering Practice. 8vo,		*1 25
Hunter, A. Bridge Work.....	8vo, (In Press.)	
Hurst, G. H. Handbook of the Theory of Color.....	8vo,	*2 50
—— Dictionary of Chemicals and Raw Products.....	8vo,	*3 00
—— Lubricating Oils, Fats and Greases.....	8vo,	*4 00
—— Soaps.....	8vo,	*5 00

14 D. VAN NOSTRAND COMPANY'S SHORT TITLE CATALOG

Hurst, G. H. Textile Soaps and Oils.....	8vo,	*2 50
Hurst, H. E., and Lattey, R. T. Text-book of Physics.....	8vo,	*3 00
— Also published in three parts.		
Part I. Dynamics and Heat.....		*1 25
Part II. Sound and Light.....		*1 25
Part III. Magnetism and Electricity.....		*1 50
Hutchinson, R. W., Jr. Long Distance Electric Power Transmission.		
	12mo,	*3 00
Hutchinson, R. W., Jr., and Ihlseng, M. C. Electricity in Mining.....	12mo,	
	(In Press)	
Hutchinson, W. B. Patents and How to Make Money Out of Them.	12mo,	1 25
Hutton, W. S. Steam-boiler Construction.....	8vo,	6 00
— Practical Engineer's Handbook.....	8vo,	7 00
— The Works' Manager's Handbook.....	8vo,	6 00
Hyde, E. W. Skew Arches. (Science Series No. 15.).....	16mo,	0 50
Induction Coils. (Science Series No. 53.).....	16mo,	0 50
Ingle, H. Manual of Agricultural Chemistry.....	8vo,	*3 00
Innes, C. H. Problems in Machine Design.....	12mo,	*2 00
— Air Compressors and Blowing Engines.....	12mo,	*2 00
— Centrifugal Pumps.....	12mo,	*2 00
— The Fan.....	12mo,	*2 00
Isherwood, B. F. Engineering Precedents for Steam Machinery....	8vo,	2 50
Ivatts, E. B. Railway Management at Stations.....	8vo,	*2 50
Jacob, A., and Gould, E. S. On the Designing and Construction of Storage Reservoirs. (Science Series No. 6.).....	16mo,	0 50
Jamieson, A. Text Book on Steam and Steam Engines.....	8vo,	3 00
— Elementary Manual on Steam and the Steam Engine.....	12mo,	1 50
Jannettaz, E. Guide to the Determination of Rocks. Trans. by G. W. Plympton.....	12mo,	1 50
Jehl, F. Manufacture of Carbons.....	8vo,	*4 00
Jennings, A. S. Commercial Paints and Painting. (Westminster Series.) 8vo (In Press.)		
Jennison, F. H. The Manufacture of Lake Pigments.....	8vo,	*3 00
Jepson, G. Cams and the Principles of their Construction.....	8vo,	*1 50
— Mechanical Drawing.....	8vo (In Preparation.)	
Jockin, W. Arithmetic of the Gold and Silversmith.....	12mo,	*1 00
Johnson, G. L. Photographic Optics and Color Photography.....	8vo,	*3 00
Johnson, J. H. Arc Lamps and Accessory Apparatus. (Installation Manuals Series.).....	12mo,	*0 75
Johnson, T. M. Ship Wiring and Fitting. (Installation Manuals Series).....	12mo,	*0 75
Johnson, W. H. The Cultivation and Preparation of Para Rubber...8vo,		*3 00
Johnson, W. McA. The Metallurgy of Nickel..... (In Preparation.)		
Johnston, J. F. W., and Cameron, C. Elements of Agricultural Chemistry and Geology.....	12mo,	2 60
Joly, J. Radioactivity and Geology.....	12mo,	*3 00
Jones, H. C. Electrical Nature of Matter and Radioactivity.....	12mo,	*2 00
Jones, M. W. Testing Raw Materials Used in Paint.....	12mo,	*2 00
Jones, L., and Scard, F. I. Manufacture of Cane Sugar.....	8vo,	*5 00

Jordan, L. C. Practical Railway Spiral.....	12mo, Leather,	*1 50
Joynson, F. H. Designing and Construction of Machine Gearing....	8vo,	2 00
Jüptner, H. F. V. Siderology: The Science of Iron.....	8vo,	*5 00
Kansas City Bridge.....	4to,	6 00
Kapp, G. Alternate Current Machinery. (Science Series No. 96.)	16mo,	0 50
— Electric Transmission of Energy.....	12mo,	3 50
Keim, A. W. Prevention of Dampness in Buildings.....	8vo,	*2 00
Keller, S. S. Mathematics for Engineering Students. 12mo, half leather.		
Algebra and Trigonometry, with a Chapter on Vectors.....		*1 75
Special Algebra Edition.....		*1 00
Plane and Solid Geometry.....		*1 25
Analytical Geometry and Calculus.....		*2 00
Kelsey, W. R. Continuous-current Dynamos and Motors.....	8vo,	*2 50
Kemble, W. T., and Underhill, C. R. The Periodic Law and the Hydrogen Spectrum.....	8vo, paper,	*0 50
Kemp, J. F. Handbook of Rocks.....	8vo,	*1 50
Kendall, E. Twelve Figure Cipher Code.....	4to,	*12 50
Kennedy, A. B. W., and Thurston, R. H. Kinematics of Machinery. (Science Series No. 54.).....	16mo,	0 50
Kennedy, A. B. W., Unwin, W. C., and Idell, F. E. Compressed Air. (Science Series No. 106.).....	16mo,	0 50
Kennedy, R. Modern Engines and Power Generators. Six Volumes. 4to,		15 00
Single Volumes.....	each,	3 00
— Electrical Installations. Five Volumes.....	4to,	15 00
Single Volumes.....	each,	3 50
— Flying Machines; Practice and Design.....	12mo,	*2 00
— Principles of Aeroplane Construction.....	8vo,	*1 50
Kennelly, A. E. Electro-dynamic Machinery.....	8vo,	1 50
Kent, W. Strength of Materials. (Science Series No. 41.).....	16mo,	0 50
Kershaw, J. B. C. Fuel, Water and Gas Analysis.....	8vo,	*2 50
— Electrometallurgy. (Westminster Series.).....	8vo,	*2 00
— The Electric Furnace in Iron and Steel Production.....	12mo,	*1 50
Kinzbrunner, C. Alternate Current Windings.....	8vo,	*1 50
— Continuous Current Armatures.....	8vo,	*1 50
— Testing of Alternating Current Machines.....	8vo,	*2 00
Kirkaldy, W. G. David Kirkaldy's System of Mechanical Testing....	4to,	10 00
Kirkbride, J. Engraving for Illustration.....	8vo,	*1 50
Kirkwood, J. P. Filtration of River Waters.....	4to,	7 50
Klein, J. F. Design of a High-speed Steam-engine.....	8vo,	*5 00
— Physical Significance of Entropy.....	8vo,	*1 50
Kleinhans, F. B. Boiler Construction.....	8vo,	3 00
Knight, R.-Adm. A. M. Modern Seamanship.....	8vo,	*7 50
Half morocco.....		*0 00
Knox, J. Physico-Chemical Calculations.....	12mo,	*1 00
Knox, W. F. Logarithm Tables..... (In Preparation.)		
Knott, C. G., and Mackay, J. S. Practical Mathematics.....	8vo,	2 00
Koester, F. Steam-Electric Power Plants.....	4to,	*5 00
— Hydroelectric Developments and Engineering.....	4to,	*5 00
Koller, T. The Utilization of Waste Products.....	8vo,	*3 50
— Cosmetics.....	8vo,	*2 50

Kirschke, A. Gas and Oil Engines.....	12mo,	*1 25
Kretchmar, K. Yarn and Warp Sizing.....	8vo,	*4 00
Lambert, T. Lead and its Compounds.....	8vo,	*3 50
— Bone Products and Manures.....	8vo,	*3 00
Lamborn, L. L. Cottonseed Products.....	8vo,	*3 00
— Modern Soaps, Candles, and Glycerin.....	8vo,	*7 50
Lamprecht, R. Recovery Work After Pit Fires. Trans. by C. Salter.	8vo,	*4 00
Lanchester, F. W. Aerial Flight. Two Volumes. 8vo.		
Vol. I. Aerodynamics.....		*6 00
— Aerial Flight. Vol. II. Aerodnetics.....		*6 00
Larner, E. T. Principles of Alternating Currents.....	12mo,	*1 25
Larrabee, C. S. Cipher and Secret Letter and Telegraphic Code....	16mo,	0 60
La Rue, B. F. Swing Bridges. (Science Series No. 107.).....	16mo,	0 50
Lassar-Cohn, Dr. Modern Scientific Chemistry. Trans. by M. M. Pattison Muir.....	12mo,	*2 00
Latimer, L. H., Field, C. J., and Howell, J. W. Incandescent Electric Lighting. (Science Series No. 57.).....	16mo,	0 50
Latta, M. N. Handbook of American Gas-Engineering Practice....	8vo,	*4 50
— American Producer Gas Practice.....	4to,	*6 00
Leask, A. R. Breakdowns at Sea.....	12mo,	2 00
— Refrigerating Machinery.....	12mo,	2 00
Lecky, S. T. S. "Wrinkles" in Practical Navigation.....	8vo,	*8 00
Le Doux, M. Ice-Making Machines. (Science Series No. 46.)....	16mo,	0 50
Leeds, C. C. Mechanical Drawing for Trade Schools.....	oblong 4to,	
High School Edition.....		*1 25
Machinery Trades Edition.....		*2 00
Lefèvre, L. Architectural Pottery. Trans. by H. K. Bird and W. M. Binns.....	4to,	*7 50
Lehner, S. Ink Manufacture. Trans. by A. Morris and H. Robson.	8vo,	*2 50
Lemstrom, S. Electricity in Agriculture and Horticulture.....	8vo,	*1 50
Le Van, W. B. Steam-Engine Indicator. (Science Series No. 78.)	16mo,	0 50
Lewes, V. B. Liquid and Gaseous Fuels. (Westminster Series.)...	8vo,	*2 00
Lewis, L. P. Railway Signal Engineering.....	8vo,	*3 50
Lieber, B. F. Lieber's Standard Telegraphic Code.....	8vo,	*10 00
— Code. German Edition.....	8vo,	*10 00
— Spanish Edition.....	8vo,	*10 00
— French Edition.....	8vo,	*10 00
— Terminal Index.....	8vo,	*2 50
— Lieber's Appendix.....	folio,	*15 00
— Handy Tables.....	4to,	*2 50
— Bankers and Stockbrokers' Code and Merchants and Shippers' Blank Tables.....	8vo,	*15 00
— 100,000,000 Combination Code.....	8vo,	*10 00
— Engineering Code.....	8vo,	*12 50
Livermore, V. P., and Williams, J. How to Become a Competent Motor-man.....	12mo,	*1 00
Livingstone, R. Design and Construction of Commutators.....	8vo,	*2 25
Lobben, P. Machinists' and Draftsmen's Handbook.....	8vo,	2 50
Locke, A. G. and C. G. Manufacture of Sulphuric Acid.....	8vo,	10 00
Lockwood, T. D. Electricity, Magnetism, and Electro-telegraph....	8vo,	2 50

Lockwood, T. D. Electrical Measurement and the Galvanometer.	12mo,	0 75
Lodge, O. J. Elementary Mechanics.....	12mo,	1 50
— Signalling Across Space without Wires.....	8vo,	*2 00
Loewenstein, L. C., and Crissey, C. P. Centrifugal Pumps.....		*4 50
Lord, R. T. Decorative and Fancy Fabrics.....	8vo,	*3 50
Loring, A. E. A Handbook of the Electromagnetic Telegraph.....	16mo,	0 50
— Handbook. (Science Series No. 39.).....	16mo,	0 50
Low, D. A. Applied Mechanics (Elementary).....	16mo,	0 80
Lubschez, B. J. Perspective.....	12mo,	*1 50
Lucke, C. E. Gas Engine Design.....	8vo,	*3 00
— Power Plants: Design, Efficiency, and Power Costs. 2 vols.		
	(In Preparation.)	
Lunge, G. Coal-tar and Ammonia. Two Volumes.....	8vo,	*15 00
— Manufacture of Sulphuric Acid and Alkali. Four Volumes.....	8vo,	
Vol. I. Sulphuric Acid. In two parts.....		*15 00
Vol. II. Salt Cake, Hydrochloric Acid and Leblanc Soda. In two parts		*15 00
Vol. III. Ammonia Soda.....		*10 00
Vol. IV. Electrolytic Methods.....	(In Press.)	
— Technical Chemists' Handbook.....	12mo, leather,	*3 50
— Technical Methods of Chemical Analysis. Trans. by C. A. Keane.		
in collaboration with the corps of specialists.		
Vol. I. In two parts.....	8vo,	*15 00
Vol. II. In two parts.....	8vo,	*18 00
Vol. III.....	(In Preparation.)	
Lupton, A., Parr, G. D. A., and Perkin, H. Electricity as Applied to		
Mining.....	8vo,	*4 50
Luquer, L. M. Minerals in Rock Sections.....	8vo,	*1 50
Macewen, H. A. Food Inspection.....	8vo,	*2 50
Mackenzie, N. F. Notes on Irrigation Works.....	8vo,	*2 50
Mackie, J. How to Make a Woolen Mill Pay.....	8vo,	*2 00
Mackrow, C. Naval Architect's and Shipbuilder's Pocket-book.		
	16mo, leather,	5 00
Maguire, Wm. R. Domestic Sanitary Drainage and Plumbing.....	8vo,	4 00
Mallet, A. Compound Engines. Trans. by R. R. Buel. (Science Series		
No. 10.).....	16mo,	
Mansfield, A. N. Electro-magnets. (Science Series No. 64.).....	16mo,	0 50
Marks, E. C. R. Construction of Cranes and Lifting Machinery.....	12mo,	*1 50
— Construction and Working of Pumps.....	12mo,	*1 50
— Manufacture of Iron and Steel Tubes.....	12mo,	*2 00
— Mechanical Engineering Materials.....	12mo,	*1 00
Marks, G. C. Hydraulic Power Engineering.....	8vo,	3 50
— Inventions, Patents and Designs.....	12mo,	*1 00
Marlow, T. G. Drying Machinery and Practice.....	8vo,	*5 00
Marsh, C. F. Concise Treatise on Reinforced Concrete.....	8vo,	*2 50
— Reinforced Concrete Compression Member Diagram. Mounted on		
Cloth Boards.....		*1 50
Marsh, C. F., and Dunn, W. Manual of Reinforced Concrete and Con-		
crete Block Construction.....	16mo, morocco,	*2 50

18 D. VAN NOSTRAND COMPANY'S SHORT TITLE CATALOG

Marshall, W. J., and Sankey, H. R. Gas Engines. (Westminster Series.)	8vo,	*2 00
Martin, G. Triumphs and Wonders of Modern Chemistry.....	8vo,	*2 00
Martin, N. Properties and Design of Reinforced Concrete.....	12mo,	*2 50
Massie, W. W., and Underhill, C. R. Wireless Telegraphy and Telephony.	12mo,	*1 00
Matheson, D. Australian Saw-Miller's Log and Timber Ready Reckoner.	12mo, leather,	1 50
Mathot, R. E. Internal Combustion Engines.....	8vo,	*6 00
Maurice, W. Electric Blasting Apparatus and Explosives.....	8vo,	*3 50
— Shot Firer's Guide.....	8vo,	*1 50
Maxwell, J. C. Matter and Motion. (Science Series No. 36.)....	16mo,	0 50
Maxwell, W. H., and Brown, J. T. Encyclopedia of Municipal and Sanitary Engineering.....	4to,	*10 00
Mayer, A. M. Lecture Notes on Physics.....	8vo,	2 00
McCullough, R. S. Mechanical Theory of Heat.....	8vo,	3 50
McIntosh, J. G. Technology of Sugar.....	8vo,	*4 50
— Industrial Alcohol.....	8vo,	*3 00
— Manufacture of Varnishes and Kindred Industries. Three Volumes.	8vo.	
Vol. I. Oil Crushing, Refining and Boiling.....		*3 50
Vol. II. Varnish Materials and Oil Varnish Making.....		*4 00
Vol. III. Spirit Varnishes and Materials.....		*4 50
McKnight, J. D., and Brown, A. W. Marine Multitubular Boilers.....		*1 50
McMaster, J. B. Bridge and Tunnel Centres. (Science Series No. 20.)	16mo,	0 50
McMechen, F. L. Tests for Ores, Minerals and Metals.....	12mo,	*1 00
McNeill, B. McNeill's Code.....	8vo,	*6 00
McPherson, J. A. Water-works Distribution.....	8vo,	2 50
Melick, C. W. Dairy Laboratory Guide.....	12mo,	*1 25
Merck, E. Chemical Reagents; Their Purity and Tests.....	8vo,	*1 50
Merritt, Wm. H. Field Testing for Gold and Silver.....	16mo, leather,	1 50
Messer, W. A. Railway Permanent Way.....	8vo, (<i>In Press.</i>)	
Meyer, J. G. A., and Pecker, C. G. Mechanical Drawing and Machine Design.....	4to,	5 00
Michell, S. Mine Drainage.....	8vo,	10 00
Mierzinski, S. Waterproofing of Fabrics. Trans. by A. Morris and H. Robson.....	8vo,	*2 50
Miller, E. H. Quantitative Analysis for Mining Engineers.....	8vo,	*1 50
Miller, G. A. Determinants. (Science Series No. 105.).....	16mo,	
Milroy, M. E. W. Home Lace-making.....	12mo,	*1 00
Minifie, W. Mechanical Drawing.....	8vo,	*4 00
Mitchell, C. F., and G. A. Building Construction and Drawing... Elementary Course.....	12mo,	*1 50
Advanced Course.....		*2 50
Mitchell, C. A., and Prideaux, R. M. Fibres Used in Textile and Allied Industries.....	8vo,	*3 00
Modern Meteorology.....	12mo,	1 50
Monckton, C. C. F. Radiotelegraphy. (Westminster Series.)....	8vo,	*2 00
Monteverde, R. D. Vest Pocket Glossary of English-Spanish, Spanish-English Technical Terms.....	64mo, leather,	*1 00

Moore, E. C. S. New Tables for the Complete Solution of Ganguillet and Kutter's Formula.	8vo,	*5 00
Morecroft, J. H., and Hehre, F. W. Short Course in Electrical Testing.	8vo,	*1 50
Moreing, C. A., and Neal, T. New General and Mining Telegraph Code, 8vo,		*5 00
Morgan, A. P. Wireless Telegraph Apparatus for Amateurs.	12mo,	*1 50
Moses, A. J. The Characters of Crystals.	8vo,	*2 00
Moses, A. J., and Parsons, C. L. Elements of Mineralogy.	8vo,	*2 50
Moss, S. A. Elements of Gas Engine Design. (Science Series No. 121.)	16mo,	0 50
— The Lay-out of Corliss Valve Gears. (Science Series No. 119.)	16mo,	0 50
Mulford, A. C. Boundaries and Landmarks.	12mo,	*1 00
Mullin, J. P. Modern Moulding and Pattern-making.	12mo,	2 50
Munby, A. E. Chemistry and Physics of Building Materials. (Westminster Series.)	8vo,	*2 00
Murphy, J. G. Practical Mining.	16mo,	1 00
Murray, J. A. Soils and Manures. (Westminster Series.)	8vo,	*2 00
Naquet, A. Legal Chemistry.	12mo,	2 00
Nasmith, J. The Student's Cotton Spinning.	8vo,	3 00
— Recent Cotton Mill Construction.	12mo,	2 00
Neave, G. B., and Heilbron, I. M. Identification of Organic Compounds.	12mo,	*1 25
Neilson, R. M. Aeroplane Patents.	8vo,	*2 00
Nerz, F. Searchlights. Trans. by C. Rodgers.	8vo,	*3 00
Nesbit, A. F. Electricity and Magnetism.	(In Preparation.)	
Neuberger, H., and Noalhat, H. Technology of Petroleum. Trans. by J. G. McIntosh.	8vo,	*10 00
Newall, J. W. Drawing, Sizing and Cutting Bevel-gears.	8vo,	1 50
Nicol, G. Ship Construction and Calculations.	8vo,	*4 50
Nipher, F. E. Theory of Magnetic Measurements.	12mo,	1 00
Nisbet, H. Grammar of Textile Design.	8vo,	*3 00
Nolan, H. The Telescope. (Science Series No. 51.)	16mo,	0 50
Noll, A. How to Wire Buildings.	12mo,	1 50
North, H. B. Laboratory Notes of Experiments in General Chemistry.	(In Press.)	
Nugent, E. Treatise on Optics.	12mo,	1 50
O'Connor, H. The Gas Engineer's Pocketbook.	12mo, leather,	3 50
— Petrol Air Gas.	12mo,	*0 75
Ohm, G. S., and Lockwood, T. D. Galvanic Circuit. Translated by William Francis. (Science Series No. 102.)	16mo,	0 50
Olsen, J. C. Text-book of Quantitative Chemical Analysis.	8vo,	*4 00
Olsson, A. Motor Control, in Turret Turning and Gun Elevating. (U. S. Navy Electrical Series, No. 1.)	12mo, paper,	*0 50
Oudin, M. A. Standard Polyphase Apparatus and Systems.	8vo,	*3 00
Pakes, W. C. C., and Nankivell, A. T. The Science of Hygiene.	8vo,	*1 75
Palaz, A. Industrial Photometry. Trans. by G. W. Patterson, Jr.	8vo,	*4 00
Pamely, C. Colliery Manager's Handbook.	8vo,	*10 00
Parr, G. D. A. Electrical Engineering Measuring Instruments.	8vo,	*3 50
Parry, E. J. Chemistry of Essential Oils and Artificial Perfumes.	8vo,	*5 00

Parry, E. J. Foods and Drugs. Two Volumes.....	8vo,	
Vol. I. Chemical and Microscopical Analysis of Foods and Drugs.		*7 50
Vol. II. Sale of Food and Drugs Act.....		*3 00
Parry, E. J., and Coste, J. H. Chemistry of Pigments.....	8vo,	*4 50
Parry, L. A. Risk and Dangers of Various Occupations.....	8vo,	*3 00
Parshall, H. F., and Hobart, H. M. Armature Windings.....	4to,	*7 50
— Electric Railway Engineering.....	4to,	*10 00
Parshall, H. F., and Parry, E. Electrical Equipment of Tramways....	(In Press.)	
Parsons, S. J. Malleable Cast Iron.....	8vo,	*2 50
Partington, J. R. Higher Mathematics for Chemical Students.....	12mo,	*2 00
Passmore, A. C. Technical Terms Used in Architecture.....	8vo,	*3 50
Paterson, G. W. L. Wiring Calculations.....	12mo,	*2 00
Patterson, D. The Color Printing of Carpet Yarns.....	8vo,	*3 50
— Color Matching on Textiles.....	8vo,	*3 00
— The Science of Color Mixing.....	8vo,	*3 00
Paulding, C. P. Condensation of Steam in Covered and Bare Pipes.....	8vo,	*2 00
— Transmission of Heat through Cold-storage Insulation.....	12mo,	*1 00
Payne, D. W. Iron Founders' Handbook.....	(In Press.)	
Peddie, R. A. Engineering and Metallurgical Books.....	12mo,	*1 50
Peirce, B. System of Analytic Mechanics.....	4to,	10 00
Pendred, V. The Railway Locomotive. (Westminster Series.)....	8vo,	*2 00
Perkin, F. M. Practical Methods of Inorganic Chemistry.....	12mo,	*1 00
Perrigo, O. E. Change Gear Devices.....	8vo,	1 00
Perrine, F. A. C. Conductors for Electrical Distribution.....	8vo,	*3 50
Perry, J. Applied Mechanics.....	8vo,	*2 50
Petit, G. White Lead and Zinc White Paints.....	8vo,	*1 50
Petit, R. How to Build an Aeroplane. Trans. by T. O'B. Hubbard, and J. H. Ledebauer.....	8vo,	*1 50
Pettit, Lieut. J. S. Graphic Processes. (Science Series No. 76.)...	16mo,	0 50
Philbrick, P. H. Beams and Girders. (Science Series No. 28.)...	16mo,	
Phillips, J. Engineering Chemistry.....	8vo,	*4 50
— Gold Assaying.....	8vo,	*2 50
— Dangerous Goods.....	8vo,	3 50
Phin, J. Seven Follies of Science.....	12mo,	*1 25
Pickworth, C. N. The Indicator Handbook. Two Volumes. 12mo, each,		1 50
— Logarithms for Beginners.....	12mo. boards,	0 50
— The Slide Rule.....	12mo,	1 00
Plattner's Manual of Blow-pipe Analysis. Eighth Edition, revised. Trans. by H. B. Cornwall.....	8vo,	*4 00
Plympton, G. W. The Aneroid Barometer. (Science Series No. 35.)	16mo,	0 50
— How to become an Engineer. (Science Series No. 100.).....	16mo,	0 50
— Van Nostrand's Table Book. (Science Series No. 104.).....	16mo,	0 50
Pochet, M. L. Steam Injectors. Translated from the French. (Science Series No. 29.).....	16mo,	0 50
Pocket Logarithms to Four Places. (Science Series No. 65.).....	16mo,	0 50
	leather,	1 00
Polleyn, F. Dressings and Finishings for Textile Fabrics.....	8vo,	*3 00
Pope, F. L. Modern Practice of the Electric Telegraph.....	8vo,	1 50
Popplewell, W. C. Elementary Treatise on Heat and Heat Engines. 12mo,		*3 00
— Prevention of Smoke.....	8vo,	*3 50
— Strength of Materials.....	8vo,	*1 75

Porter, J. R. Helicopter Flying Machine.....	12mo,	*1 25
Potter, T. Concrete.....	8vo,	*3 00
Potts, H. E. Chemistry of the Rubber Industry. (Outlines of Industrial Chemistry).....	8vo,	*2 00
Practical Compounding of Oils, Tallow and Grease.....	8vo,	*3 50
Practical Iron Founding.....	12mo,	1 50
Pratt, K. Boiler Draught.....	12mo,	*1 25
Pray, T., Jr. Twenty Years with the Indicator.....	8vo,	2 50
— Steam Tables and Engine Constant.....	8vo,	2 00
— Calorimeter Tables.....	8vo,	1 00
Preece, W. H. Electric Lamps.....	(In Press.)	
Prelini, C. Earth and Rock Excavation.....	8vo,	*3 00
— Graphical Determination of Earth Slopes.....	8vo,	*2 00
— Tunneling. New Edition.....	8vo,	*3 00
— Dredging. A Practical Treatise.....	8vo,	*3 00
Prescott, A. B. Organic Analysis.....	8vo,	5 00
Prescott, A. B., and Johnson, O. C. Qualitative Chemical Analysis.....	8vo,	*3 50
Prescott, A. B., and Sullivan, E. C. First Book in Qualitative Chemistry.....	12mo,	*1 50
Prideaux, E. B. R. Problems in Physical Chemistry.....	8vo,	*2 00
Pritchard, O. G. The Manufacture of Electric-light Carbons.....	8vo, paper,	*0 60
Pullen, W. W. F. Application of Graphic Methods to the Design of Structures.....	12mo,	*2 50
— Injectors: Theory, Construction and Working.....	12mo,	*1 50
Pulsifer, W. H. Notes for a History of Lead.....	8vo,	4 00
Purchase, W. R. Masonry.....	12mo,	*3 00
Putsch, A. Gas and Coal-dust Firing.....	8vo,	*3 00
Pynchon, T. R. Introduction to Chemical Physics.....	8vo,	3 00
Rafter G. W. Mechanics of Ventilation. (Science Series No. 33.).....	16mo,	0 50
— Potable Water. (Science Series No. 103.).....	16mc	50
— Treatment of Septic Sewage. (Science Series No. 118.).....	16mo	50
Rafter, G. W., and Baker, M. N. Sewage Disposal in the United States.....	4to,	*6 00
Raikes, H. P. Sewage Disposal Works.....	8vo,	*4 00
Railway Shop Up-to-Date.....	4to,	2 00
Ramp, H. M. Foundry Practice.....	(In Press.)	
Randall, P. M. Quartz Operator's Handbook.....	12mo,	2 00
Randau, P. Enamels and Enamelling.....	8vo,	*4 00
Rankine, W. J. M. Applied Mechanics.....	8vo,	5 00
— Civil Engineering.....	8vo,	6 50
— Machinery and Millwork.....	8vo,	5 00
— The Steam-engine and Other Prime Movers.....	8vo,	5 00
— Useful Rules and Tables.....	8vo,	4 00
Rankine, W. J. M., and Bamber, E. F. A Mechanical Text-book.....	8vo,	3 50
Raphael, F. C. Localization of Faults in Electric Light and Power Mains.....	8vo,	*3 00
Rasch, E. Electric Arc Phenomena. Trans. by K. Tornberg.....	(In Press.)	
Rathbone, R. L. B. Simple Jewellery.....	8vo,	*2 00
Rateau, A. Flow of Steam through Nozzles and Orifices. Trans. by H. B. Brydon.....	8vo,	*1 50

22 D. VAN NOSTRAND COMPANY'S SHORT TITLE CATALOG

Rausenberger, F. The Theory of the Recoil of Guns.....	8vo,	*4	50
Rautenstrauch, W. Notes on the Elements of Machine Design.....	8vo, boards,	*1	50
Rautenstrauch, W., and Williams, J. T. Machine Drafting and Empirical Design.			
Part I. Machine Drafting.....	8vo,	*1	25
Part II. Empirical Design.....	(In Preparation.)		
Raymond, E. B. Alternating Current Engineering.....	12mo,	*2	50
Rayner, H. Silk Throwing and Waste Silk Spinning.....	8vo,	*2	50
Recipes for the Color, Paint, Varnish, Oil, Soap and Drysaltery Trades.....	8vo,	*3	50
Recipes for Flint Glass Making.....	12mo,	*4	50
Redfern, J. B. Bells, Telephones (Installation Manuals Series).....	16mo,		
	(In Press.)		
Redwood, B. Petroleum. (Science Series No. 92.).....	16mo,	0	50
Reed's Engineers' Handbook.....	8vo,	*5	00
— Key to the Nineteenth Edition of Reed's Engineers' Handbook.....	8vo,	*3	00
— Useful Hints to Sea-going Engineers.....	12mo,	1	50
— Marine Boilers.....	12mo,	2	00
— Guide to the Use of the Slide Valve.....	12mo,	*1	60
Reinhardt, C. W. Lettering for Draftsmen, Engineers, and Students.			
	oblong 4to, boards,	1	00
— The Technic of Mechanical Drafting.....	oblong 4to, boards,	*1	00
Reiser, F. Hardening and Tempering of Steel. Trans. by A. Morris and H. Robson.....	12mo,	*2	50
Reiser, N. Faults in the Manufacture of Woolen Goods. Trans. by A. Morris and H. Robson.....	8vo,	*2	50
— Spinning and Weaving Calculations.....	8vo,	*5	00
Renwick, W. G. Marble and Marble Working.....	8vo,	5	00
Reynolds, O., and Idell, F. E. Triple Expansion Engines. (Science Series No. 99.).....	16mo,	0	50
Rhead, G. F. Simple Structural Woodwork.....	12mo,	*1	00
Rice, J. M., and Johnson, W. W. A New Method of Obtaining the Differential of Functions.....	12mo,	0	50
Richards, W. A., and North, H. B. Manual of Cement Testing.....	12mo,	*1	50
Richardson, J. The Modern Steam Engine.....	8vo,	*3	50
Richardson, S. S. Magnetism and Electricity.....	12mo,	*2	00
Rideal, S. Glue and Glue Testing.....	8vo,	*4	00
Rimmer, E. J. Boiler Explosions, Collapses and Mishaps.....	8vo,	*1	75
Rings, F. Concrete in Theory and Practice.....	12mo,	*2	50
Ripper, W. Course of Instruction in Machine Drawing.....	folio,	*6	00
Roberts, F. C. Figure of the Earth. (Science Series No. 79.).....	16mo,	0	50
Roberts, J., Jr. Laboratory Work in Electrical Engineering.....	8vo,	*2	00
Robertson, L. S. Water-tube Boilers.....	8vo,	2	00
Robinson, J. B. Architectural Composition.....	8vo,	*2	50
Robinson, S. W. Practical Treatise on the Teeth of Wheels. (Science Series No. 24.).....	16mo,	0	50
— Railroad Economics. (Science Series No. 59.).....	16mo,	0	50
— Wrought Iron Bridge Members. (Science Series No. 60.).....	16mo,	0	50
Robson, J. H. Machine Drawing and Sketching.....	8vo,	*1	50
Roebing, J. A. Long and Short Span Railway Bridges.....	folio,	25	00
Rogers, A. A Laboratory Guide of Industrial Chemistry.....	12mo,	*1	50
Rogers, A., and Aubert, A. B. Industrial Chemistry.....	8vo,	*5	00

Rogers, F. Magnetism of Iron Vessels. (Science Series No. 30.)	16mo,	0 50
Rohland, P. Colloidal and Crystalloidal State of Matter. Trans. by W. J. Britland and H. E. Potts	12mo,	*1 25
Rollins, W. Notes on X-Light	8vo,	*5 00
Rollinson, C. Alphabets	Oblong, 12mo,	*1 00
Rose, J. The Pattern-makers' Assistant	8vo,	2 50
— Key to Engines and Engine-running	12mo,	2 50
Rose, T. K. The Precious Metals. (Westminster Series.)	8vo,	*2 00
Rosenhain, W. Glass Manufacture. (Westminster Series.)	8vo,	*2 00
Ross, W. A. Plowpipe in Chemistry and Metallurgy	12mo,	*2 00
Rossiter, J. T. Steam Engines. (Westminster Series.)	8vo (<i>In Press.</i>)	
— Pumps and Pumping Machinery. (Westminster Series.)	8vo,	
	(<i>In Press.</i>)	
Roth. Physical Chemistry	8vo,	*2 00
Rouillion, L. The Economics of Manual Training	8vo,	2 00
Rowan, F. J. Practical Physics of the Modern Steam-boiler	8vo,	*3 00
Rowan, F. J., and Idell, F. E. Boiler Incrustation and Corrosion. (Science Series No. 27.)	16mo,	0 50
Roxburgh, W. General Foundry Practice	8vo,	*3 50
Ruhmer, E. Wireless Telephony. Trans. by J. Erskine-Murray	8vo,	*3 50
Russell, A. Theory of Electric Cables and Networks	8vo,	*3 00
Sabine, R. History and Progress of the Electric Telegraph	12mo,	1 25
Saeltzer A. Treatise on Acoustics	12mo,	1 00
Salomons, D. Electric Light Installations. 12mo.		
Vol. I. The Management of Accumulators		2 50
Vol. II. Apparatus		2 25
Vol. III. Applications		1 50
Sanford, P. G. Nitro-explosives	8vo,	*4 00
Saunders, C. H. Handbook of Practical Mechanics	16mo,	1 00
	leather,	1 25
Saunier, C. Watchmaker's Handbook	12mo,	3 00
Sayers, H. M. Brakes for Tram Cars	8vo,	*1 25
Scheele, C. W. Chemical Essays	8vo,	*2 00
Schellen, H. Magneto-electric and Dynamo-electric Machines	8vo,	5 00
Scherer, R. Casein. Trans. by C. Salter	8vo,	*3 00
Schidrowitz, P. Rubber, Its Production and Industrial Uses	8vo,	*5 00
Schindler, K. Iron and Steel Construction Works	12mo,	*1 25
Schmall, C. N. First Course in Analytic Geometry, Plane and Solid.		
	12mo, half leather,	*1 75
Schmall, C. N., and Shack, S. M. Elements of Plane Geometry	12mo,	*1 25
Schmeer, L. Flow of Water	8vo,	*3 00
Schumann, F. A Manual of Heating and Ventilation	12mo, leather,	1 50
Schwarz, E. H. L. Causal Geology	8vo,	*2 50
Schweizer, V., Distillation of Resins	8vo,	*3 50
Scott, W. W. Qualitative Analysis. A Laboratory Manual	8vo,	*1 50
Scribner, J. M. Engineers' and Mechanics' Companion	16mo, leather,	1 50
Searle, A. B. Modern Brickmaking	8vo,	*5 00
Searle, G. M. "Summers' Method." Condensed and Improved. (Science Series No. 124.)	16mo,	0 50
Seaton, A. E. Manual of Marine Engineering	8vo,	6 00

Seaton, A. E., and Rounthwaite, H. M. Pocket-book of Marine Engineering.....	16mo, leather,	3 00
Seeligmann, T., Torrilhon, G. L., and Falconnet, H. India Rubber and Gutta Percha. Trans. by J. G. McIntosh.....	8vo,	*5 00
Seidell, A. Solubilities of Inorganic and Organic Substances.....	8vo,	*3 00
Sellew, W. H. Steel Rails.....	4to (<i>In Press.</i>)	
Senter, G. Outlines of Physical Chemistry.....	12mo,	*1 75
— Textbook of Inorganic Chemistry.....	12mo,	*1 75
Sever, G. F. Electric Engineering Experiments.....	8vo, boards,	*1 00
Sever, G. F., and Townsend, F. Laboratory and Factory Tests in Electrical Engineering.....	8vo,	*2 50
Sewall, C. H. Wireless Telegraphy.....	8vo,	*2 00
— Lessons in Telegraphy.....	12mo,	*1 00
Sewell, T. Elements of Electrical Engineering.....	8vo,	*3 00
— The Construction of Dynamos.....	8mo,	*3 00
Sexton, A. H. Fuel and Refractory Materials.....	12mo,	*2 50
— Chemistry of the Materials of Engineering.....	12mo,	*2 50
— Alloys (Non-Ferrous).....	8vo,	*3 00
— The Metallurgy of Iron and Steel.....	8vo,	*6 50
Seymour, A. Practical Lithography.....	8vo,	*2 50
— Modern Printing Inks.....	8vo,	*2 00
Shaw, Henry S. H. Mechanical Integrators. (<i>Science Series No. 83.</i>)	16mo,	0 50
Shaw, P. E. Course of Practical Magnetism and Electricity.....	8vo,	*1 00
Shaw, S. History of the Staffordshire Potteries.....	8vo,	*3 00
— Chemistry of Compounds Used in Porcelain Manufacture.....	8vo,	*5 00
Shaw, W. N. Forecasting Weather.....	8vo,	*3 50
Sheldon, S., and Hausmann, E. Direct Current Machines.....	12mo,	*2 50
— Alternating Current Machines.....	12mo,	*2 50
Sheldon, S., and Hausmann, E. Electric Traction and Transmission Engineering.....	12mo,	*2 50
Sherriff, F. F. Oil Merchants' Manual.....	12mo,	*3 50
Shields, J. E. Notes on Engineering Construction.....	12mo,	1 50
Shock, W. H. Steam Boilers.....	4to, half morocco,	15 00
Shreve, S. H. Strength of Bridges and Roofs.....	8vo,	3 50
Shunk, W. F. The Field Engineer.....	12mo, morocco,	2 50
Simmons, W. H., and Appleton, H. A. Handbook of Soap Manufacture.	8vo,	*3 00
Simmons, W. H., and Mitchell, C. A. Edible Fats and Oils.....	8vo,	*3 00
Simms, F. W. The Principles and Practice of Leveling.....	8vo,	2 50
— Practical Tunneling.....	8vo,	7 50
Simpson, G. The Naval Constructor.....	12mo, morocco,	*5 00
Simpson, W. Foundations.....	8vo, (<i>In Press.</i>)	
Sinclair, A. Development of the Locomotive Engine.....	8vo, half leather,	5 00
— Twentieth Century Locomotive.....	8vo, half leather,	*5 00
Sindall, R. W., and Bacon, W. N. The Testing of Wood Pulp.....	8vo,	*2 50
Sindall, R. W. Manufacture of Paper. (<i>Westminster Series.</i>).....	8vo,	*2 00
Sloane, T. O'C. Elementary Electrical Calculations.....	12mo,	*2 00
Smith, C. A. M. Handbook of Testing, MATERIALS.....	8vo,	*2 50
Smith, C. A. M., and Warren, A. G. New Steam Tables.....	8vo,	
Smith, C. F. Practical Alternating Currents and Testing.....	8vo,	*2 50

Smith, C. F. Practical Testing of Dynamos and Motors.....	8vo,	*2 00
Smith, F. E. Handbook of General Instruction for Mechanics....	12mo,	1 50
Smith, J. C. Manufacture of Paint.....	8vo,	*3 00
Smith, R. H. Principles of Machine Work.....	12mo,	*3 00
— Elements of Machine Work.....	12mo,	*2 00
Smith, W. Chemistry of Hat Manufacturing.....	12mo,	*3 00
Snell, A. T. Electric Motive Power.....	8vo,	*4 00
Snow, W. G. Pocketbook of Steam Heating and Ventilation. (<i>In Press.</i>)		
Snow, W. G., and Nolan, T. Ventilation of Buildings. (Science Series No. 5).....	16mo,	0 50
Soddy, F. Radioactivity.....	8vo,	*3 00
Solomon, M. Electric Lamps. (Westminster Series).....	8vo,	*2 00
Sothern, J. W. The Marine Steam Turbine.....	8vo,	*5 00
Southcombe, J. E. Paints, Oils and Varnishes. (Outlines of Industrial Chemistry).....	8vo, (<i>In Press.</i>)	
Soxhlet, D. H. Dyeing and Staining Marble. Trans. by A. Morris and H. Robson.....	8vo,	*2 50
Spang, H. W. A Practical Treatise on Lightning Protection....	12mo,	1 00
Spangenburg, L. Fatigue of Metals. Translated by S. H. Shreve. (Science Series No. 23.).....	16mo,	0 50
Specht, G. J., Hardy, A. S., McMaster, J. B., and Walling. Topographical Surveying. (Science Series No. 72.).....	16mo,	0 50
Speyers, C. L. Text-book of Physical Chemistry.....	8vo,	*2 25
Stahl, A. W. Transmission of Power. (Science Series No. 28.)...	16mo,	
Stahl, A. W., and Woods, A. T. Elementary Mechanism.....	12mo,	*2 00
Staley, C., and Pierson, G. S. The Separate System of Sewerage....	8vo,	*3 00
Standage, H. C. Leatherworkers' Manual.....	8vo,	*3 50
— Sealing Waxes, Wafers, and Other Adhesives.....	8vo,	*2 00
— Agglutinants of all Kinds for all Purposes.....	12mo,	*3 50
Stansbie, J. H. Iron and Steel. (Westminster Series).....	8vo,	*2 00
Steadman, F. M. Unit Photography and Actinometry..... (<i>In Press.</i>)		
Steinman, D. B. Suspension Bridges and Cantilevers. (Science Series No. 127).....		0 50
Stevens, H. P. Paper Mill Chemist.....	16mo,	*2 50
Stevenson, J. L. Blast-Furnace Calculations.....	12mo, leather,	*2 00
Stewart, A. Modern Polyphase Machinery.....	12mo,	*2 00
Stewart, G. Modern Steam Traps.....	12mo,	*1 25
Stiles, A. Tables for Field Engineers.....	12mo,	1 00
Stillman, P. Steam-engine Indicator.....	12mo,	1 00
Stodola, A. Steam Turbines. Trans. by L. C. Loewenstein.....	8vo,	*5 00
Stone, H. The Timbers of Commerce.....	8vo,	3 50
Stone, Gen. R. New Roads and Road Laws.....	12mo,	1 00
Stopes, M. Ancient Plants.....	8vo,	*2 00
— The Study of Plant Life.....	8vo,	*2 00
Stumpf, Prof. Una-Flow of Steam Engine.....	4to,	*3 50
Sudborough, J. J., and James, T. C. Practical Organic Chemistry....	12mo,	*2 00
Suffling, E. R. Treatise on the Art of Glass Painting.....	8vo,	*3 50
Suggate, A. Elements of Engineering Estimating.....	12mo,	
Swan, K. Patents, Designs and Trade Marks. (Westminster Series). 8vo,		*2 00
Sweet, S. H. Special Report on Coal.....	8vo,	3 00

26 D. VAN NOSTRAND COMPANY'S SHORT TITLE CATALOG

Swinburne, J., Wordingham, C. H., and Martin, T. C. Electric Currents. (Science Series No. 109.).....	16mo,	0 50
Swoope, C. W. Practical Lessons in Electricity.....	12mo,	*2 00
Tailfer, L. Bleaching Linen and Cotton Yarn and Fabrics.....	8vo,	*5 00
Tate, J. S. Surcharged and Different Forms of Retaining-walls. (Science Series No. 7.).....	16mo,	0 50
Taylor, E. N. Small Water Supplies.....	12mo,	*2 00
Templeton, W. Practical Mechanic's Workshop Companion.	12mo, morocco,	2 00
Terry, H. L. India Rubber and its Manufacture. (Westminster Series.)	8vo,	*2 00
Thayer, H. R. Structural Design. 8vo. Vol. I. Elements of Structural Design.....		*2 00
Vol. II. Design of Simple Structures.....(In Preparation.)		
Vol. III. Design of Advanced Structures.....(In Preparation.)		
Thiess, J. B. and Joy, G. A. Toll Telephone Practice.....	8vo,	*3 50
Thom, C., and Jones, W. H. Telegraphic Connections.....	oblong 12mo,	1 50
Thomas, C. W. Paper-makers' Handbook.....(In Press.)		
Thompson, A. B. Oil Fields of Russia.....	4to,	*7 50
— Petroleum Mining and Oil Field Development.....	8vo,	*5 00
Thompson, E. P. How to Make Inventions.....	8vo,	0 50
Thompson, S. P. Dynamo Electric Machines. (Science Series No. 75.)	16mo,	0 50
Thompson, W. P. Handbook of Patent Law of All Countries.....	16mo,	1 50
Thomson, G. S. Milk and Cream Testing.....	12mo,	*1 75
— Modern Sanitary Engineering, House Drainage, etc.....	8vo,	*3 00
Thornley, T. Cotton Combing Machines.....	8vo,	*3 00
— Cotton Spinning. 8vo. First Year.....		*1 50
Second Year.....		*2 50
Third Year.....		*2 50
Thurso, J. W. Modern Turbine Practice.....	8vo,	*4 00
Tidy, C. Meymott. Treatment of Sewage. (Science Series No. 94.).....	16mo,	0 50
Tinney, W. H. Gold-mining Machinery.....	8vo,	*3 00
Titherley, A. W. Laboratory Course of Organic Chemistry.....	8vo,	*2 00
Toch, M. Chemistry and Technology of Mixed Paints.....	8vo,	*3 00
— Materials for Permanent Painting.....	12mo,	*2 00
Todd, J., and Whall, W. B. Practical Seamanship.....	8vo,	*7 50
Tonge, J. Coal. (Westminster Series.).....	8vo,	*2 00
Townsend, F. Alternating Current Engineering.....	8vo, boards	*0 75
Townsend, J. Ionization of Gases by Collision.....	8vo,	*1 25
Transactions of the American Institute of Chemical Engineers. 8vo. Vol. I. 1908.....		*6 00
Vol. II. 1909.....		*6 00
Vol. III. 1910.....		*6 00
Vol. IV. 1911.....		*6 00
Traverse Tables. (Science Series No. 115.).....	16mo,	0 50
	morocco,	1 00
Trinks, W., and Housum, C. Shaft Governors. (Science Series No. 122.)	16mo,	0 50

D. VAN NOSTRAND COMPANY'S SHORT TITLE CATALOG 27

Trowbridge, W. P. Turbine Wheels. (Science Series No. 44.).....	16mo,	0 50
Tucker, J. H. A Manual of Sugar Analysis.....	8vo,	3 50
Tumlirz, O. Potential. Trans. by D. Robertson.....	12mo,	1 25
Tunner, P. A. Treatise on Roll-turning. Trans. by J. B. Pearse.	8vo, text and folio atlas,	10 00
Turbayne, A. A. Alphabets and Numerals.....	4to,	2 00
Turnbull, Jr., J., and Robinson, S. W. A Treatise on the Compound Steam-engine, (Science Series No. 8.).....	16mo,	
Turrill, S. M. Elementary Course in Perspective.....	12mo,	*1 25
Underhill, C. R. Solenoids, Electromagnets and Electromagnetic Wind- ings.....	12mo,	*2 00
Universal Telegraph Cipher Code.....	12mo,	1 00
Urquhart, J. W. Electric Light Fitting.....	12mo,	2 00
— Electro-plating.....	12mo,	2 00
— Electrotyping.....	12mo,	2 00
— Electric Ship Lighting.....	12mo,	3 00
Usborne, P. O. G. Design of Simple Steel Bridges.....	8vo,	*4 00
Vacher, F. Food Inspector's Handbook.....	12mo,	*2 50
Van Nostrand's Chemical Annual. Second issue 1909.....	12mo,	*2 50
— Year Book of Mechanical Engineering Data. First issue 1912... (<i>In Press.</i>)		
Van Wagenen, T. F. Manual of Hydraulic Mining.....	16mo,	1 00
Vega, Baron Von. Logarithmic Tables.....	8vo, half morocco,	2 00
Villon, A. M. Practical Treatise on the Leather Industry. Trans. by F. T. Addyman.....	8vo,	*10 00
Vincent, C. Ammonia and its Compounds. Trans. by M. J. Salter.....	8vo,	*2 00
Volk, C. Haulage and Winding Appliances.....	8vo,	*4 00
Von Georgievics, G. Chemical Technology of Textile Fibres. Trans. by C. Salter.....	8vo,	*4 50
— Chemistry of Dyestuffs. Trans. by C. Salter.....	8vo,	*4 50
Vose, G. L. Graphic Method for Solving Certain Questions in Arithmetic and Algebra. (Science Series No. 16.).....	16mo,	0 50
Wabner, R. Ventilation in Mines. Trans. by C. Salter.....	8vo,	*4 50
Wade, E. J. Secondary Batteries.....	8vo,	*4 00
Wadmore, T. M. Elementary Chemical Theory.....	12mo,	*1 50
Wadsworth, C. Primary Battery Ignition.....	12mo,	*0 50
Wagner, E. Preserving Fruits, Vegetables, and Meat.....	12mo,	*2 50
Waldram, P. J. Principles of Structural Mechanics.....	12mo,	*3 00
Walker, F. Aerial Navigation.....	8vo,	2 00
— Dynamo Building. (Science Series No. 98.).....	16mo,	0 50
— Electric Lighting for Marine Engineers.....	8vo,	2 00
Walker, S. F. Steam Boilers, Engines and Turbines.....	8vo,	3 00
— Refrigeration, Heating and Ventilation on Shipboard.....	12mo,	*2 00
— Electricity in Mining.....	8vo,	*3 50
Walker, W. H. Screw Propulsion.....	8vo,	0 75
Wallis-Tayler, A. J. Bearings and Lubrication.....	8vo,	*1 50
— Aerial or Wire Ropeways.....	8vo,	*3 00
— Modern Cycles.....	8vo,	4 00
— Motor Cars.....	8vo,	1 80
— Motor Vehicles for Business Purposes.....	8vo,	3 50

Wallis-Taylor, A. J. Pocket Book of Refrigeration and Ice Making. 12mo,	1	50
— Refrigeration, Cold Storage and Ice-Making.	8vo,	*4 50
— Sugar Machinery.	12mo,	*2 00
Wanklyn, J. A. Water Analysis.	12mo,	2 00
Wansbrough, W. D. The A B C of the Differential Calculus.	12mo,	*1 50
— Slide Valves.	12mo,	*2 00
Ward, J. H. Steam for the Million.	8vo,	1 00
Waring, Jr., G. E. Sanitary Conditions. (Science Series No. 31.)	16mo,	0 50
— Sewerage and Land Drainage.		*6 00
Waring, Jr., G. E. Modern Methods of Sewage Disposal.	12mo,	2 00
— How to Drain a House.	12mo,	1 25
Warren, F. D. Handbook on Reinforced Concrete.	12mo,	*2 50
Watkins, A. Photography. (Westminster Series.)	8vo,	*2 00
Watson, E. P. Small Engines and Boilers.	12mo,	1 25
Watt, A. Electro-plating and Electro-refining of Metals.	8vo,	*4 50
— Electro-metallurgy	12mo,	1 00
— The Art of Soap-making.	8vo,	3 00
— Leather Manufacture.	8vo,	*4 00
— Paper-Making.	8vo,	3 00
Weale, J. Dictionary of Terms Used in Architecture.	12mo,	2 50
Weale's Scientific and Technical Series. (Complete list sent on applica- tion.)		
Weather and Weather Instruments.	12mo,	1 00
	paper,	0 50
Webb, H. L. Guide to the Testing of Insulated Wires and Cables. 12mo,		1 00
Webber, W. H. Y. Town Gas. (Westminster Series.)	8vo,	*2 00
Weisbach, J. A Manual of Theoretical Mechanics.	8vo,	*6 00
	sheep,	*7 50
Weisbach, J., and Herrmann, G. Mechanics of Air Machinery.	8vo,	*3 75
Welch, W. Correct Lettering. (In Press.)		
Weston, E. B. Loss of Head Due to Friction of Water in Pipes	12mo,	*1 50
Weymouth, F. M. Drum Armatures and Commutators.	8vo,	*3 00
Wheatley, O. Ornamental Cement Work. (In Press.)		
Wheeler, J. B. Art of War.	12mo,	1 75
— Field Fortifications.	12mo,	1 75
Whipple, S. An Elementary and Practical Treatise on Bridge Building. 8vo,		3 00
White, A. T. Toothed Gearing	12mo,	*1 25
Whithard, P. Illuminating and Missal Painting.	12mo,	1 50
Wilcox, R. M. Cantilever Bridges. (Science Series No. 25.)	16mo,	0 50
Wilda, H. Steam Turbines. Trans. by C. Salter	12mo,	1 25
Wilkinson, H. D. Submarine Cable Laying and Repairing.	8vo,	*6 00
Williams, A. D., Jr., and Hutchinson, R. W. The Steam Turbine. (In Press.)		
Williamson, J., and Blackadder, H. Surveying.	8vo, (In Press.)	
Williamson, R. S. On the Use of the Barometer.	4to,	15 00
— Practical Tables in Meteorology and Hypsometry.	4to,	2 50
Willson, F. N. Theoretical and Practical Graphics.	4to,	*4 00
Wilson, F. J., and Heilbron, I. M. Chemical Theory and Calculations. 12mo,		*1 00
Wimperis, H. E. Internal Combustion Engine.	8vo,	*3 00
— Primer of Internal Combustion Engine.	12mo,	*1 00

Winchell, N. H., and A. N. Elements of Optical Mineralogy.....	8vo,	*3 50
Winkler, C., and Lunge, G. Handbook of Technical Gas-Analysis....	8vo,	4 00
Winslow, A. Stadia Surveying. (Science Series No. 77.).....	16mo,	0 50
Wisser, Lieut. J. P. Explosive Materials. (Science Series No. 70.).	16mo,	0 50
Wisser, Lieut. J. P. Modern Gun Cotton. (Science Series No. 89.)	16mo,	0 50
Wood, De V. Luminiferous Aether. (Science Series No. 85.)....	16mo,	0 50
Woodbury, D. V. Elements of Stability in the Well-proportioned Arch.	8vo, half morocco,	4 00
Worden, E. C. The Nitrocellulose Industry. Two Volumes.....	8vo,	*10 00
— Cellulose Acetate.....	8vo, (<i>In Press.</i>)	
Wright, A. C. Analysis of Oils and Allied Substances.....	8vo,	*3 50
— Simple Method for Testing Painters' Materials.....	8vo,	*2 50
Wright, F. W. Design of a Condensing Plant.....	12mo,	*1 50
Wright, H. E. Handy Book for Brewers.....	8vo,	*5 00
Wright, J. Testing, Fault Finding, etc., for Wiremen. (Installation Manuals Series.).....	16mo,	*0 50
Wright, T. W. Elements of Mechanics.....	8vo,	*2 50
Wright, T. W., and Hayford, J. F. Adjustment of Observations....	8vo,	*3 00
Young, J. E. Electrical Testing for Telegraph Engineers.....	8vo,	*4 00
Zahner, R. Transmission of Power. (Science Series No. 40.)....	16mo,	
Zeidler, J., and Lustgarten, J. Electric Arc Lamps.....	8vo,	*2 00
Zeuner, A. Technical Thermodynamics. Trans. by J. F. Klein. Two Volumes.....	8vo,	*8 00
Zimmer, G. F. Mechanical Handling of Material.....	4to,	*10 00
Zipser, J. Textile Raw Materials. Trans. by C. Salter.....	8vo,	*5 00
Zur Nedden, F. Engineering Workshop Machines and Processes. Trans. by J. A. Davenport.....	8vo	*2 00

D. VAN NOSTRAND COMPANY

are prepared to supply, either from
their complete stock or at
short notice,

Any Technical or Scientific Book

In addition to publishing a very large and varied number of SCIENTIFIC AND ENGINEERING BOOKS, D. Van Nostrand Company have on hand the largest assortment in the United States of such books issued by American and foreign publishers.

All inquiries are cheerfully and carefully answered and complete catalogs sent free on request.

25 PARK PLACE NEW YORK

LIBRARY OF CONGRESS



0 021 213 209 3